



4096-270  
August 10, 1998  
Revision C

Assembly Manual

# **1.8M ANTENNA SYSTEM W/DUAL AXIS TRACKING MOUNT**

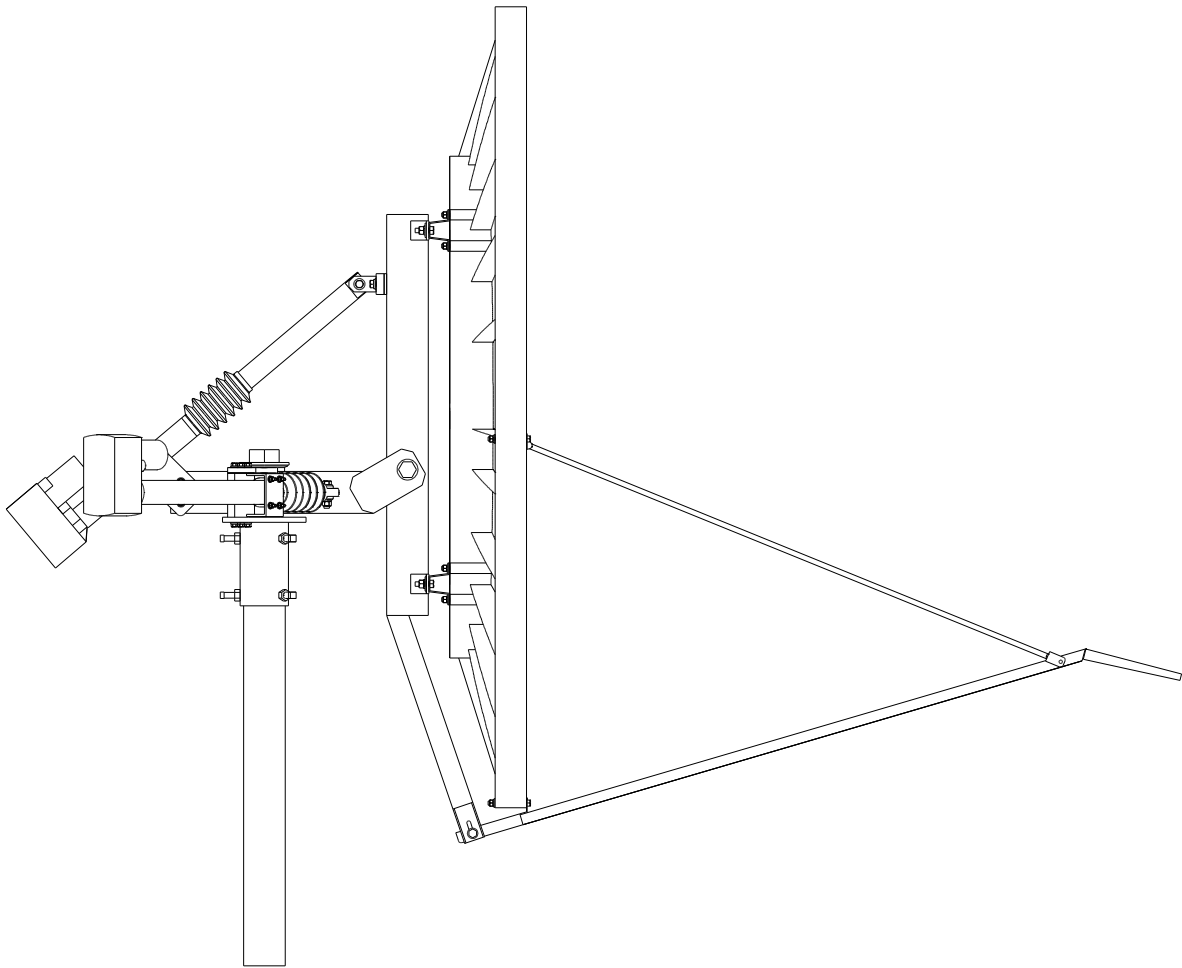
**PRODELIN CORPORATION  
1500 PRODELIN DRIVE  
NEWTON NC 28658**

# 1.8M Antenna System W/Dual Axis Tracking Mount

C	Overall update	08/10/98	
B	Revised controller Specifications	03/27/98	PGW
A	Release for production	08/19/93	R.F.
-	ORIGINAL RELEASE	08/06/93	R.F.
<b>REV.</b>	<b>DESCRIPTION</b>	<b>DATE</b>	<b>APPROVED</b>

**TABLE OF CONTENTS**

<b><u>SECTION</u></b>	<b><u>TITLE</u></b>
<b>I</b>	<b>GENERAL INFORMATION</b>
1.0	INTRODUCTION
1.1	UNPACKING AND INSPECTION
1.2	MECHANICAL INSTALLATION TOOLS
1.3	SITE SELECTION
1.4	SUGGESTED MAST & FOUNDATION
<b>II</b>	<b>REFLECTOR ASSEMBLY</b>
2.0	PART LIST
2.1	DUAL AXIS TRACKING MOUNT INSTALLATION
<b>III</b>	<b>FEED SUPPORT ASSEMBLY</b>
3.0	PART LIST
3.1	FEED SUPPORT INSTALLATION
<b>IV</b>	<b>ANTENNA TRACKING CONTROLLER SET UP</b>
4.0	ANTENNA CONTROLLER UNIT SET UP
4.1	SEA TEL SAT 90 CONTROLLER – INITIAL SET UP
4.2	SEA TEL HDT 91 CONTROLLER – INITIAL SET UP
4.3	WIRING CONTROLLER TO ACTUATORS
<b>V</b>	<b>SATELLITE ALIGNMENT</b>
5.0	SATELLITE ALIGNMENT
<b>VI</b>	<b>MAINTENANCE</b>
6.0	MAINTENANCE OVERVIEW
6.1	PERIODIC INSPECTION
6.2	REFLECTOR
6.3	MOUNT AND REFLECTOR SUPPORT
6.4	FEED AND FEED SUPPORT
6.5	BEARINGS
6.6	ACTUATOR



**SECTION I            GENERAL INFORMATION****1.0    INTRODUCTION**

This manual describes the assembly and installation of Prodelin's 1.8 meter antenna system with dual axis tracking. The Prodelin 1.8M is a rugged, reliable antenna system which will withstand the effects of the environment.

These instructions are listed by sections that cover all areas of assembly and installation. Additional sections are included in the manual to provide information on antenna alignment to the satellite and maintenance.

**1.1    UNPACKING AND INSPECTION**

1.    **UNPACKING & INSPECTION** - The antenna containers should be unpacked and inspected at the earliest date to ensure that all material has been received and is in good condition. A complete packing list for each major component is supplied.
  
2.    **FREIGHT DAMAGE** - Any damage to materials while in transit should be immediately directed to the freight carrier. He will instruct you on the matters regarding any freight damage claims.
  
3.    **MATERIAL - MISSING OR DAMAGED** - Any questions regarding missing or damaged materials that is not due to freight carrier should be directed to Prodelin's Customer Service Department at:

**PRODELIN CORPORATION  
1500 PRODELIN DRIVE  
NEWTON, NORTH CAROLINA 28658  
USA  
(828) 464-4141**

**1.2 MECHANICAL INSTALLATION TOOLS**

<b>HARDWARE SIZE</b>	<b>SAE WRENCH SIZE</b>	<b>METRIC WRENCH SIZE</b>	<b>MAXIMUM REC. TORQUE</b>
<b>5 / 16"</b>	<b>1 / 2"</b>	<b>13 mm</b>	<b>12 ft-lbs</b>
<b>3 / 8"</b>	<b>9 / 16"</b>	<b>14 mm</b>	<b>15 ft-lbs</b>
<b>1 / 2"</b>	<b>3 / 4"</b>	<b>20 mm</b>	<b>35 ft-lbs</b>

Also recommended for installation:

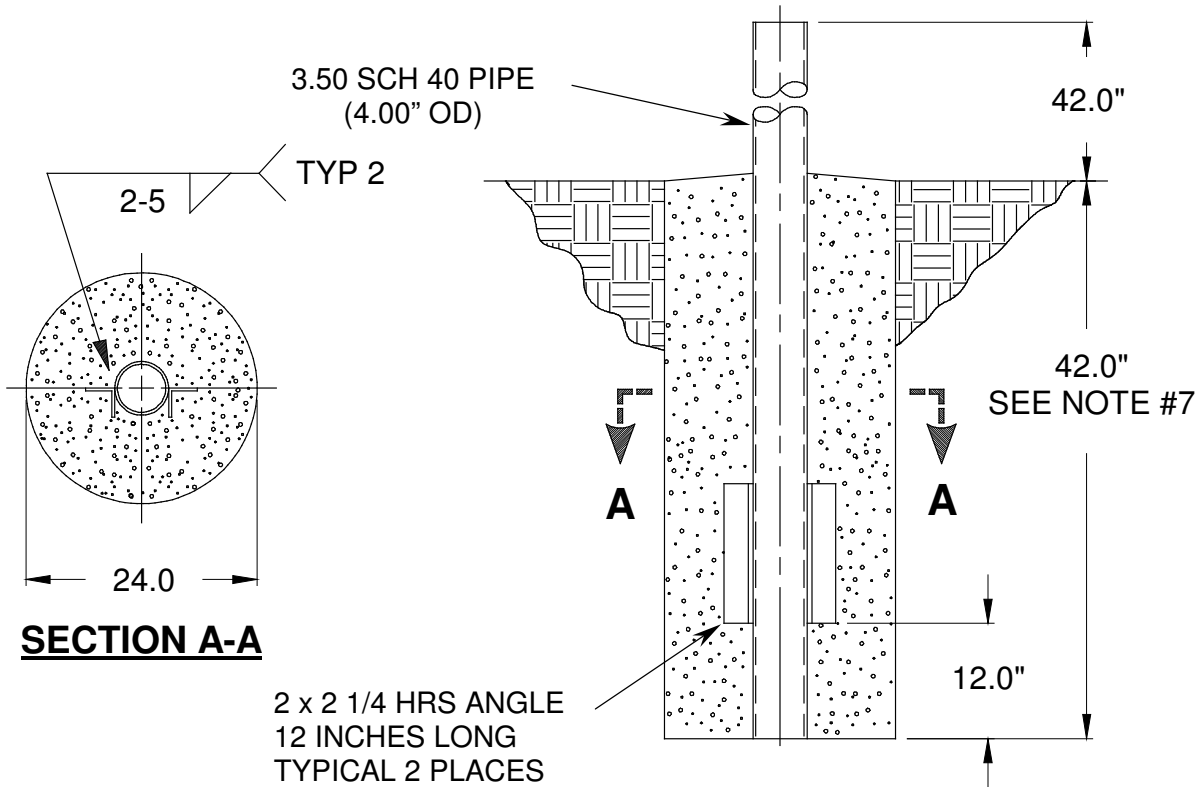
Adjustable Wrench 10"  
 Ratchet (3 / 8" & 1 / 2" Drive)  
 3" Wrench ( socket, crescent or pipe) for 2" bolt  
 Inclinometer  
 Compass  
 ASCII Hand Held Terminal (A personal computer with ASCII Emulator  
 Software can be used)

**1.3 SITE SELECTION**

In order to achieve maximum performance of your antenna system, it is important to select the correct location for the antenna. The following guidelines should be observed when selecting a site for the installation.

1. The line of site to the satellite should be clear of any obstructions, such as trees or buildings.
2. The site should be relatively flat and level for ease of installation and access to the antenna.
3. The site should be checked for underground obstruction, such as buried cables or pipes.
4. All local building codes should be adhered to (i.e. grounding, foundation requirements, zoning rules, setbacks, etc.).

**1.4 SUGGESTED MAST & FOUNDATION**



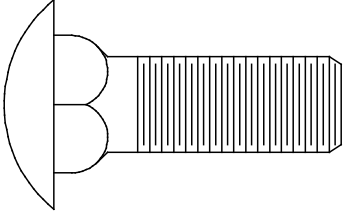
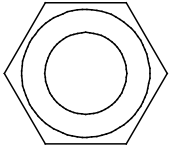
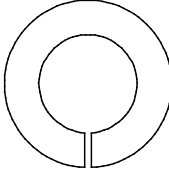
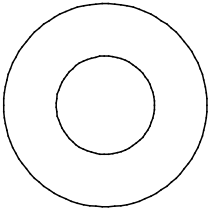
**Figure 1**

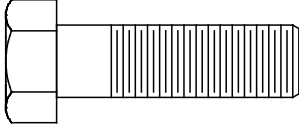
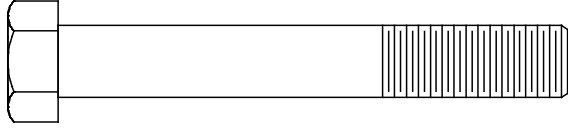
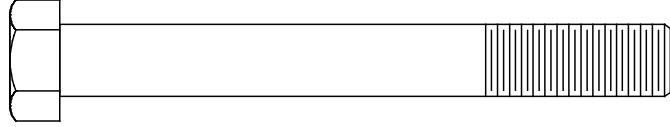
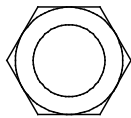
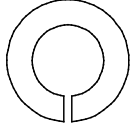
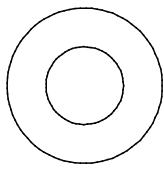
**NOTES:**

1. 2 x 2 x 1/4 HRS Angle and schedule 40 pipe should conform with ASTM A36 and ASTM A53 Type E and S Grade B.
2. All concrete should conform to building code standards and have a minimum compressive strength of 3000 PSI at 28 days. (Per ACI-318-77)
3. Soil bearing capacity should be no less than 2000 PSF.
4. Concrete should be poured against undisturbed soil.
5. Allow concrete 24 hours set time before installation of antenna.
6. The antenna should be properly grounded to meet applicable local codes.
7. Minimum depth as shown or extend to local frost line.
8. Foundation meets the design requirements as set forth by the uniform building code. (1982 edition)

(PRODELIN CORPORATION DOES NOT REPRESENT OR WARRANT THAT ANY PARTICULAR DESIGN OR SIZE OF FOUNDATION IS APPROPRIATE FOR ANY LOCALITY OR EARTH STATION INSTALLATION.)

**SECTION II      REFLECTOR ASSEMBLY**

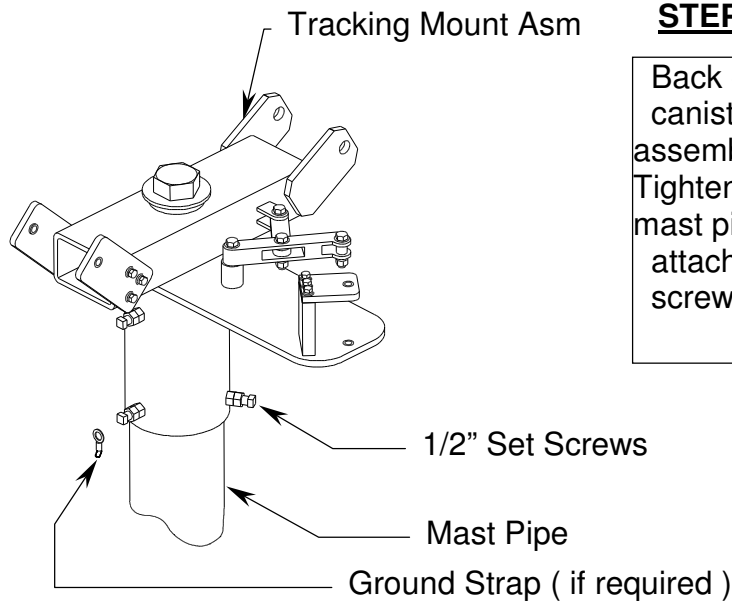
<b>REFLECTOR ASSEMBLY PART LIST - TABLE 2.0</b>			
<b>ITEM</b>	<b>PART NO.</b>	<b>DESCRIPTION</b>	<b>QTY</b>
1	VARIES	1.8M REFLECTOR	1
2	0181-286	1.8M TRACKING MOUNT ASSEMBLY	1
3	0181-292	ELEVATION ACTUATOR / GIMBAL ASM - 24"	1
4	0181-294	AZIMUTH ACTUATOR / GIMBAL ASM - 18"	1
5	0211-417	CROSS ARMS	2
6	8043-014	1 / 2" x 1.50" CARRIAGE BOLT	4
			
7	8104-007	1 / 2" HEX NUT	4
			
8	8202-043	1 / 2" LOCK WASHER	4
			
9	8201-043	1 / 2" WASHER	4
			

PARTS LIST - CONTINUED			
ITEM	PART NO.	DESCRIPTION	QTY
10	8032-010	3 / 8" x 1.25" HEX BOLT 	4
11	8032-036	3 / 8" x 4.5" HEX BOLT 	4
12	8032-040	3 / 8" x 5.0" HEX BOLT 	4
13	8102-007	3 / 8" HEX NUT 	12
14	8202-042	3 / 8" LOCK WASHER 	12
15	8201-042	3 / 8" WASHER 	24

**CAUTION:** During the assembly procedure, the sequence of instructions must be

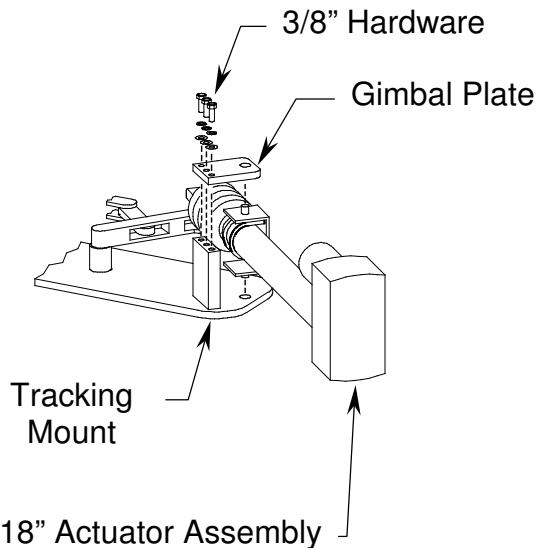
followed. **Do Not Tighten Any Hardware Until Instructed.** Refer to the antenna assembly parts list and the following steps.

**2.1 DUAL AXIS TRACKING MOUNT INSTALLATION**



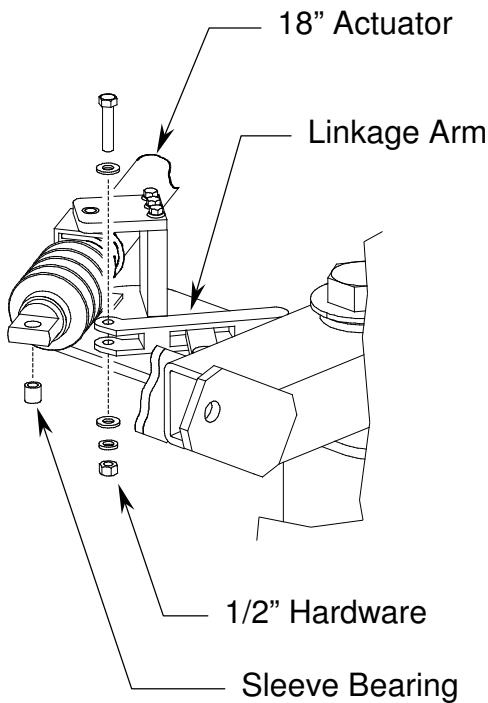
**STEP 1:**

Back out the [6] 1/2" set screws from the canister and slip the tracking mount assembly (item 2) over the mast pipe. Tighten the set screws snug against the mast pipe. Note; a ground strap can be attached at this stage to one of the set screws.



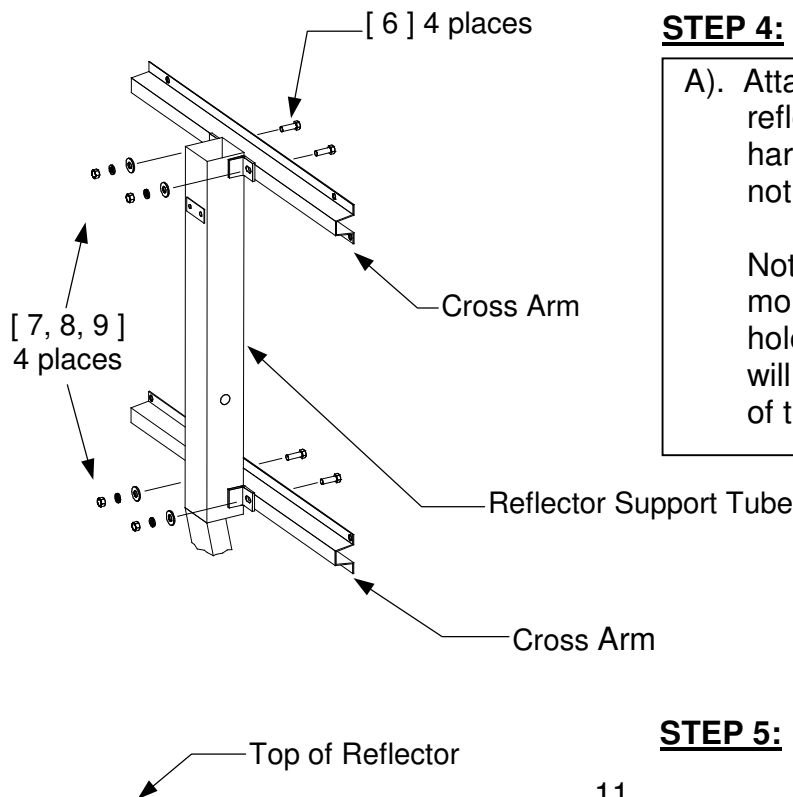
**STEP 2:**

- A) Remove the 3/8" hardware and the gimbal mount plate from the tracking mount.
- B) Install one post of the 18" actuator (item 4) into the hole in the bottom plate of the tracking mount. Note that the arrow located on the actuator motor must point up.
- C) Re install the gimbal mounting plate. Be sure that the bearing face on the plate is towards the gimbal. Note that the actuator/gimbal assembly is pre-set at the factory and needs no adjustment.



**STEP 3:**

- A) Remove the 1/2" hardware and sleeve bearing from the tab on the end of the azimuth linkage on the tracking mount.
- B) Slide the bearing sleeve through the swivel ball on the end of the 18" actuator.
- C) Move the actuator so that the holes in bearing and linkages arm are in line with each other.
- D) Reinsert the 1/2" hardware and tighten until the lockwasher is flat. Then tighten another half turn.

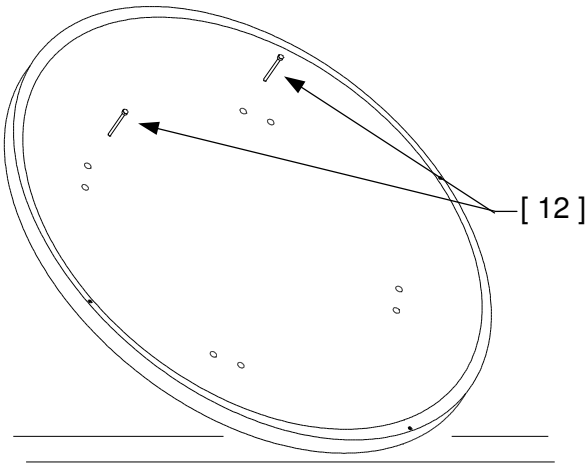


**STEP 4:**

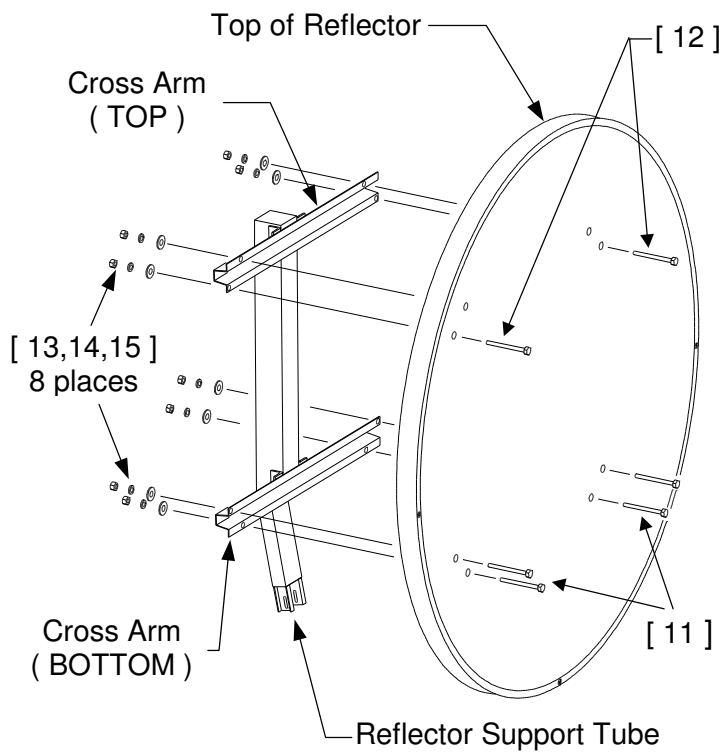
- A). Attach cross arms ( Item 5 ) to the reflector support tube with 1 / 2" hardware ( items: 6,7,8,9). Do not tighten.

Note the orientation of reflector mounting holes, the inner most holes on the cross arm flanges will be to the top and the bottom of the reflector.

**STEP 5:**

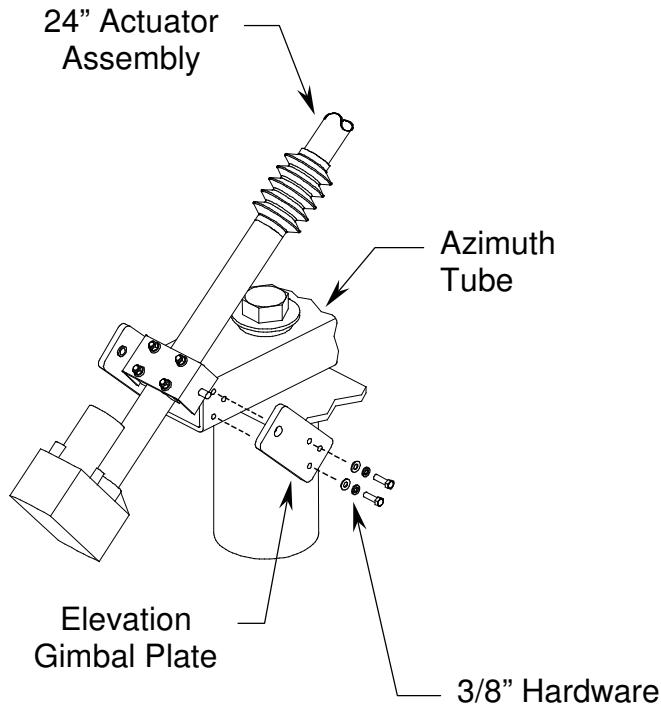


A). Locate the top of the reflector and insert (2) 5" bolts ( item 12 ) thru top two inner most holes on face of reflector as shown.



**STEP 6:**

- A). With a person on each side of the reflector, lift the reflector up.
- B). Position the reflector so that the (2) bolts (step 5) pass thru the two inner holes in the top cross arm.
- C). Loosely attach 3 / 8" hardware (items 13,14,15). **Note:** the reflector is fully supported at this time.
- D). Insert the (2) remaining 5" bolts (item 12) thru the remaining two holes on top of reflector.
- E). Insert the (4) 4.5" bolts (item 11) thru the four bottom holes in reflector.
- F). Secure with (items 13, 14, 15).
- G). Using the torque specifications on page 6, tighten all reflector and mount hardware, with the exception of the 1 / 2" carriage bolts (they will be tightened in section III)

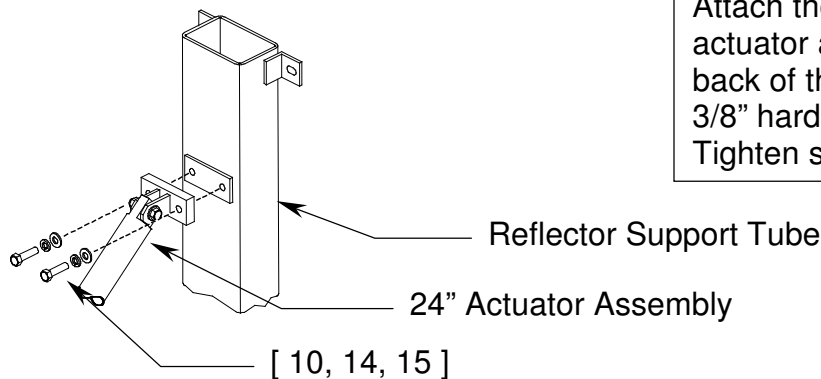


**STEP 7:**

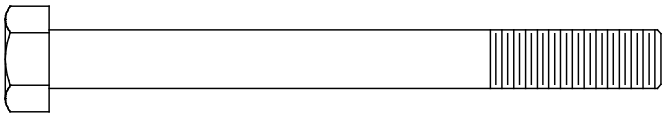
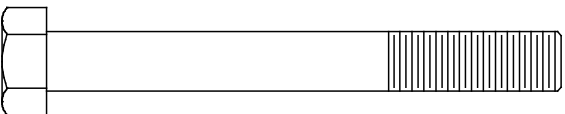
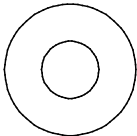
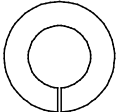
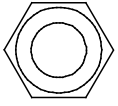
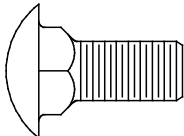
- A) Remove one of the elevation gimbal plates from the azimuth tube on the tracking mount.
- B) Insert one post of the 24" actuator gimbal assembly (item 3) into the other elevation gimbal plate. Note that the arrow located on the actuator motor must point up.
- C) Re install the elevation gimbal plate. Be sure that the bearing face on the plate is towards the gimbal.

**STEP 8:**

Attach the opposite end of the 24" actuator assembly to the plate on the back of the reflector support tube with 3/8" hardware (items 10, 14, 15). Tighten securely.



These instructions are intended as a general reference for feed support assembly. If your antenna system has specific feed or feed support installation instructions, please refer to them at this time.

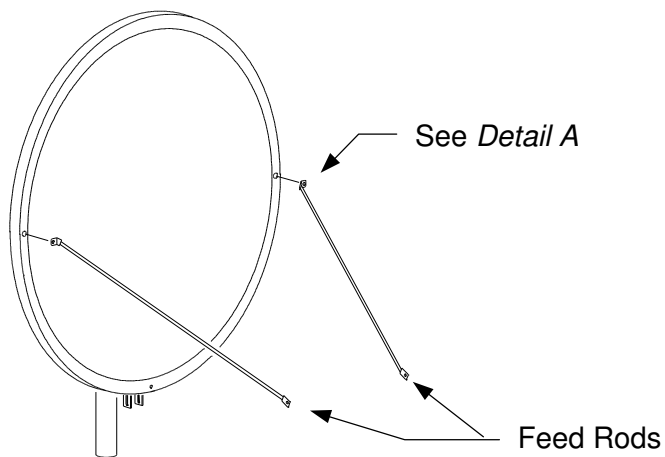
1.8M FEED SUPPORT PART LIST - TABLE 3.0			
ITEM NO.	PART NO.	DESCRIPTION	QTY
1	VARIABLES	Feed Rod	2
2	VARIABLES	Feed Support Tube	1
3	8031-030	5 / 16" x 3.75" Bolt 	3
4	8031-026	5 / 16" x 3.25" Bolt 	1
5	8201-041	5 / 16" Flatwasher 	10
6	8202-041	5 / 16" Lock Washer 	6
7	8101-009	5 / 16" Hex Nut 	6
8	8038-006	5 / 16" x .75" Carriage Bolt 	2

**3.1 FEED SUPPORT INSTALLATION**

**CAUTION:** During the assembly procedure, the sequence of instructions must be followed. **Do Not Tighten Any Hardware Until Instructed.** Refer to the feed support parts list and the steps shown below.

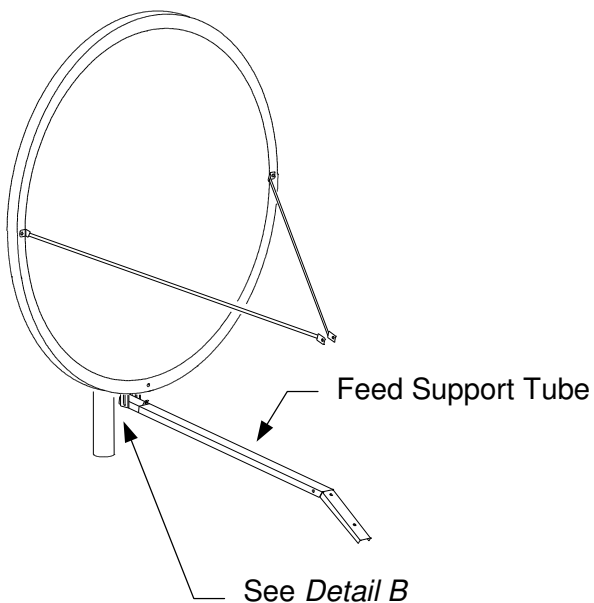
### **STEP 1:**

- A). Attach right and left feed rods to the reflector with (items 3, 6, 7) and with (2) of ( item 5 ). See Figure 2 and Detail A.

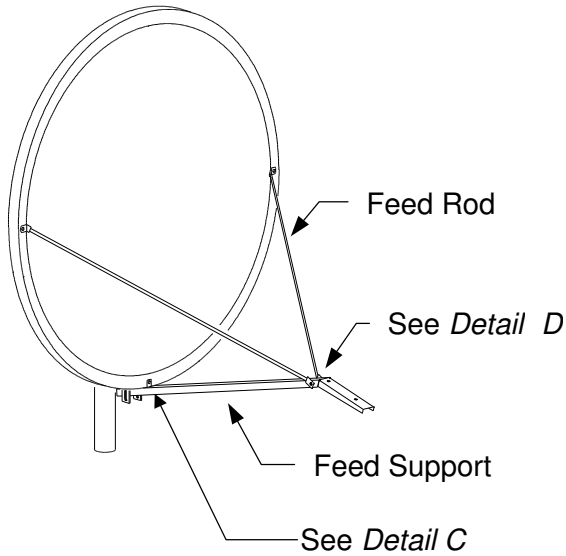


### **STEP 2:**

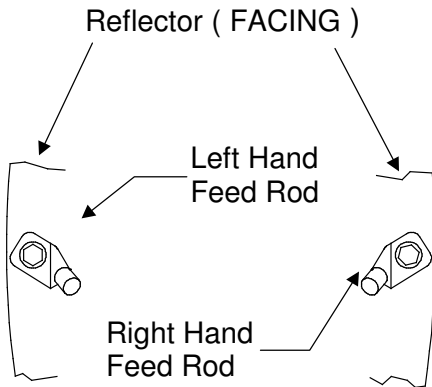
- A). Before attaching the feed support, sight the bottom of the reflector with the reflector support tube, to be sure the reflector is centered. If not, move the reflector left or right along the crossarms. See Figure 3.
- B). Loosely mount the bottom of the feed support to the reflector support tube with (2) of ( items 8, 5, 6, 7 ). See Detail B.



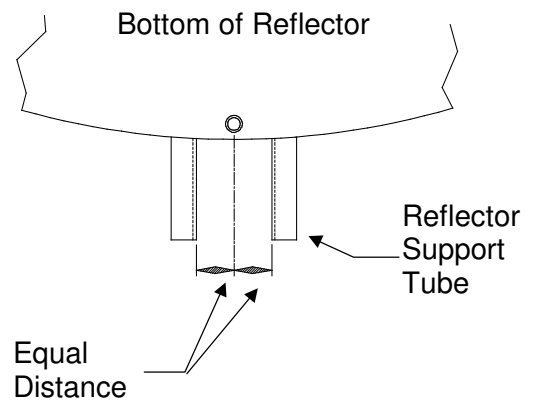
### **STEP 3:**



- A). Attach feed support to the bottom of the reflector with ( items 3, 6, 7 ) and (2) of ( item 5 ). See Detail C.
- B). Connect the feed rods to the end of the feed support with (items 4, 6, 7) and (2) of ( item 5 ). See detail D
- C). Tighten the 1 / 2" carriage bolts to the reflector crossarms using the required torque specs on page 6.
- D). Tighten all feed assembly hardware using the required torque specs on page 6.

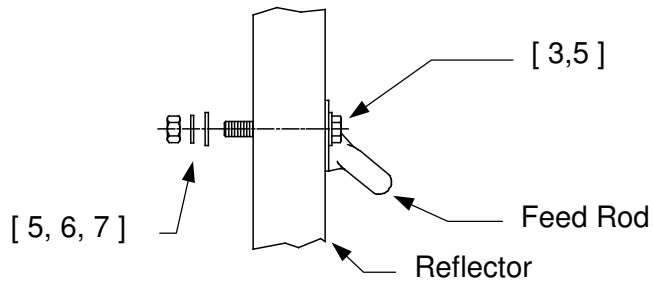


**FIGURE 2**

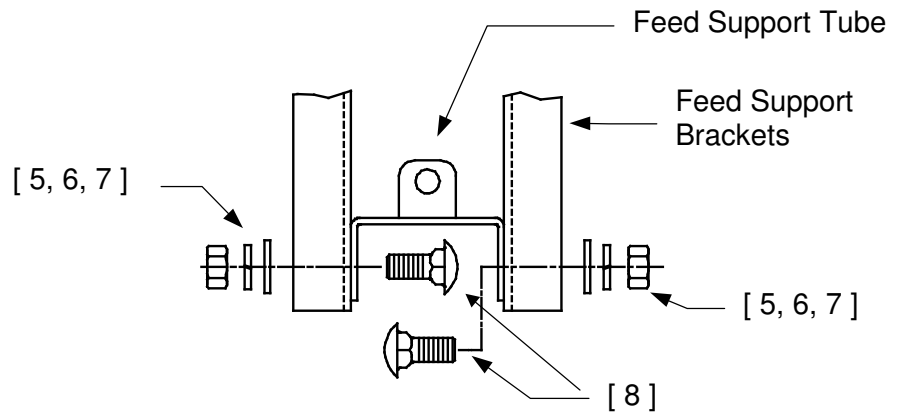


**FIGURE 3**

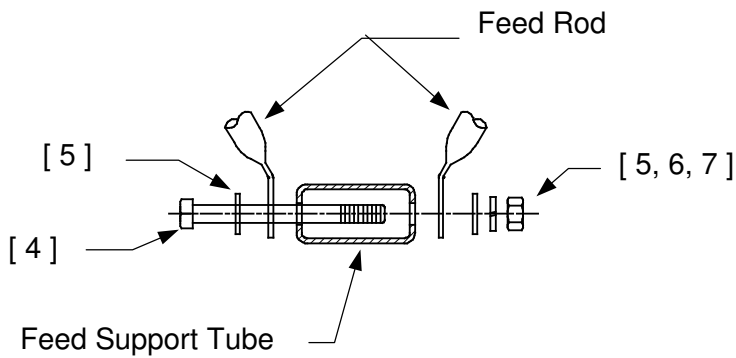
**DETAIL A**



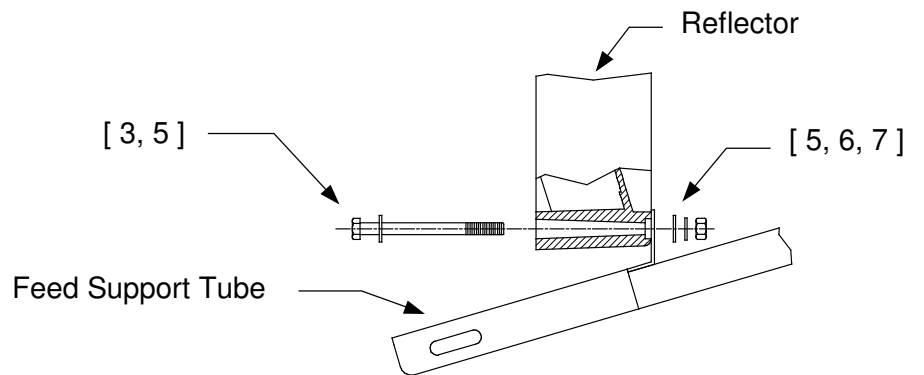
**DETAIL B**



**DETAIL D**



**DETAIL C**



**SECTION IV**

**ANTENNA TRACKING CONTROLLER SET-UP**

#### 4.0 ANTENNA CONTROLLER UNIT SET-UP

Prodelin recommends using the Sea Tel SAT 90 or Sea Tel HDT 91 tracking antenna controller when using the Prodelin dual axis tracking mount. These antenna controllers and the dual axis mount are designed to track one inclined orbit satellite. The antenna controllers are available with several different options depending on the customers needs. The options are as follows:

1. External AGC input from external receiver.
2. Wide band receiver built-in.
3. 70 MHz receiver built-in.
4. L-band receiver built-in.

Each option has some minor differences but all operate in the same manner. The instructions below will customize the SAT 90 or HDT 91 antenna controller for the Prodelin dual axis tracking mount.

FRONT OF CONTROLLER

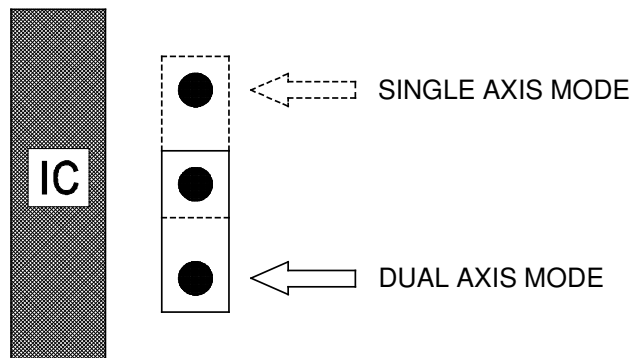


Figure 4

#### 4.1 SEA TEL SAT 90 ANTENNA CONTROLLER INITIAL SET-UP

These instructions are for the Sea Tel Controller Unit, Model# SAT 90. This controller is designed to be installed using an ASCII hand held terminal or a personal computer with ASCII emulation software.

- STEP 1:** Remove the top of the SAT 90 by removing the four screws on the sides of the controller.
- STEP 2:** Remove the jumper next to the I.C. See figure 4. **NOTE:** If the controller has a narrow band receiver board it will need to be unfastened and moved aside (NOT DISCONNECTED) to allow access to the jumper next to the I.C.
- STEP 3:** Connect the ASCII hand held terminal to the SAT 90.
- STEP 4:** Plug the SAT 90 unit into the AC outlet and reset the controller (red button in the back of unit). The display on the ASCII terminal will read "Production Test Mode". Type in "M" to put into manual mode.
- STEP 5:** Using "7↔9" on the keyboard, adjust the "Search Adjustment Range" to 17. Then type "U" to store the new value.
- STEP 6:** Replace the jumper as shown in figure 4.
- STEP 7:** Reset the controller. The display will read "Dual Axis Mode-Zeroing Actuators".
- STEP 8:** Unplug the controller. Newly input parameters are stored in non-volatile memory.

## 4.2 SEA TEL HDT 91 ANTENNA CONTROLLER INITIAL SET-UP

These instructions are for the Sea Tel Controller Unit, Model # HDT 91. This controller is designed to be installed using an ASCII hand held terminal or a personal computer with ASCII emulation software.

- STEP 1:** Remove the top of the HDT 91 by removing the screws on the top cover of the controller.
- STEP 2:** Remove the jumper next to the I.C. See figure 4. **NOTE:** If the controller has a narrow band receiver board it will need to be unfastened and moved aside (NOT DISCONNECTED) to allow access to the jumper next to the I.C.
- STEP 3:** Connect the ASCII hand held terminal to the HDT 91 (via the RS232 connector).
- STEP 4:** Plug the HDT 91 unit into the AC outlet and reset the controller (red button in the back of unit). The display on the ASCII terminal will read "Production Test Mode". Type in "M" to put into manual mode.
- STEP 5:** Using "A ⇔ B" on the keyboard, adjust the "Azimuth Actuator Range" to 15.
- STEP 6:** Using "C ⇔ D" on the keyboard, adjust the "Elevation Actuator Range" to 16.
- STEP 7:** Using "7 ⇔ 9" on the keyboard, adjust the "Declination Search Range" to 13.
- STEP 8:** Type "U" to store the new values in NVRAM.
- STEP 9:** Replace the jumper as shown in figure 4.
- STEP 10:** Reset the controller. The display will read "Dual Axis Mode-Zeroing Actuators".
- STEP 11:** Unplug the controller. Newly input parameters are stored in non-volatile memory.

### 4.3 WIRING CONTROLLER TO ACTUATORS

Refer to figure 5 and follow the instructions in the listed sequence.

- STEP 1:** Remove the actuator covers by loosening the three screws on the back of the actuators.
- STEP 2:** Connect wires as shown in figure 5. Make sure the Antenna Control Unit is unplugged when connecting wires.

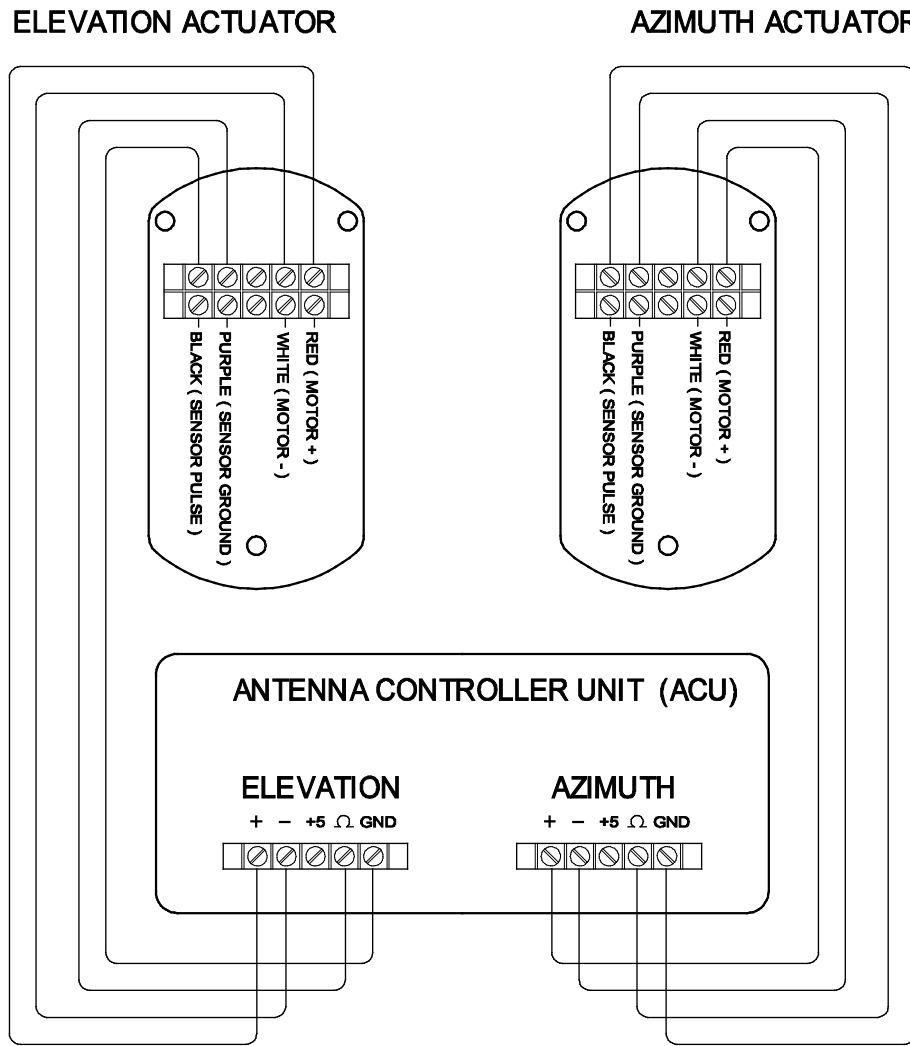


Figure 5

**SECTION V SATELLITE ALIGNMENT**

**5.0 SATELLITE ALIGNMENT**

STEP 1: Use LOTUS™ SPREAD SHEET "SATPOS.WK1" that is provided with the Sea Tel controller to calculate set-up parameters, then print out the results. Satellite and earth station locations plus the actuator ratios need to be given. These ratios are mount dependant and are the worst case degree of movement per inch of actuator travel. The final result will be the information pertaining to the location of the center of the orbital envelope. See example below.

SAT 90 AZIMUTH / ELEVATION / AZ RATIO SETTINGS REV B

ANTENNA LATITUDE	35.1 N
ANTENNA LONGITUDE	83.3 W
SATELLITE POS	93.0 W
AZIMUTH	196.6
ELEVATION	47.9
AZIMUTH DEGREES/IN	3.95
ELEVATION DEGREES/IN	2.20
AZ RATIO	-22.8

STEP 2: Plug the SAT 90 controller into the AC outlet and press the reset button. The display on the hand held ASCII terminal will read "DUAL AXIS MODE - ZEROING ACTUATORS". Then once the actuators have zeroed a message "WIDE ANGLE SEARCH IN 10 SEC" will appear on the display. Type "M" to put the SAT 90 controller into manual mode.

STEP 3: The Azimuth ratio number, which was calculated in the LOTUS spread sheet, must be set using the ASCII terminal. Type "X ⇔ Z" to raise and lower the number and type "Y" to change the sign.

STEP 4: The internal receiver Frequency number, which is looked up on Table 2 in the SAT 90 controller manual (Doc. NO. 111332), must be set using the ASCII terminal, type "G ⇔ H" to raise and lower the number.

STEP 5: Type "U" to store changes in non-volatile memory.

STEP 6: The ASCII terminal will be used to position the actuators in the installation position (approximately half the travel of the actuators). Type "I" to move the actuators to the install position. In this position the azimuth and elevation must be adjusted to point the antenna system as close to the azimuth and elevation settings as possible.

- STEP 7: The azimuth is adjusted by loosening two of the six square head set screws on the track mount assembly and rotating the assembly on the support pole. Once the azimuth is on the correct direction, the square head set screws are readjusted and tightened to assure the track mount assembly is level and secure on the support pole. The correct direction of the satellite can be determined using a high quality compass. When azimuth is being set, the local magnetic deviation must be taken into account. Also, compass must be at least 10 feet away from large metal objects.
- STEP 8: The elevation is adjusted by loosening the four hex nuts on the elevation gimbal and sliding the gimbal to the correct location on the actuator tube. The four hex nuts are then tightened to secure the gimbal. NOTE: DO NOT OVER TIGHTEN THE FOUR HEX NUTS BECAUSE THE ACTUATORS CAN BE PERMANENTLY DAMAGED! Tighten the hex nuts 1/2 a turn after the split lockwashers flatten out. The setup angle is the elevation angle from the LOTUS spread sheet minus the 22.3 offset angle. This setup angle should be measured using an inclinometer as shown in figure 5. NOTE: To insure that the mount will have the full +/- 10 of travel in elevation. it is important to set the reflector support tube angle within +/- 1 of the setup angle.
- STEP 9: The controller can now be used to move the antenna system up and down using the "C ⇕ D" keys and left and right using the "A ⇔ B" keys to locate the signal from the satellite. Once the signal is found then type "M" to activate the Automatic Mode. The Automatic Mode begins the 24 hour satellite acquisition sequence. If no signal is found, a Wide Angle Search Mode will search along the declination axis looking for the signal. If no signal is found in the Wide Angle Search, rotate the antenna in azimuth (step #7) and type "W" again. Once the signal is found type "M" to activate Automatic Mode.

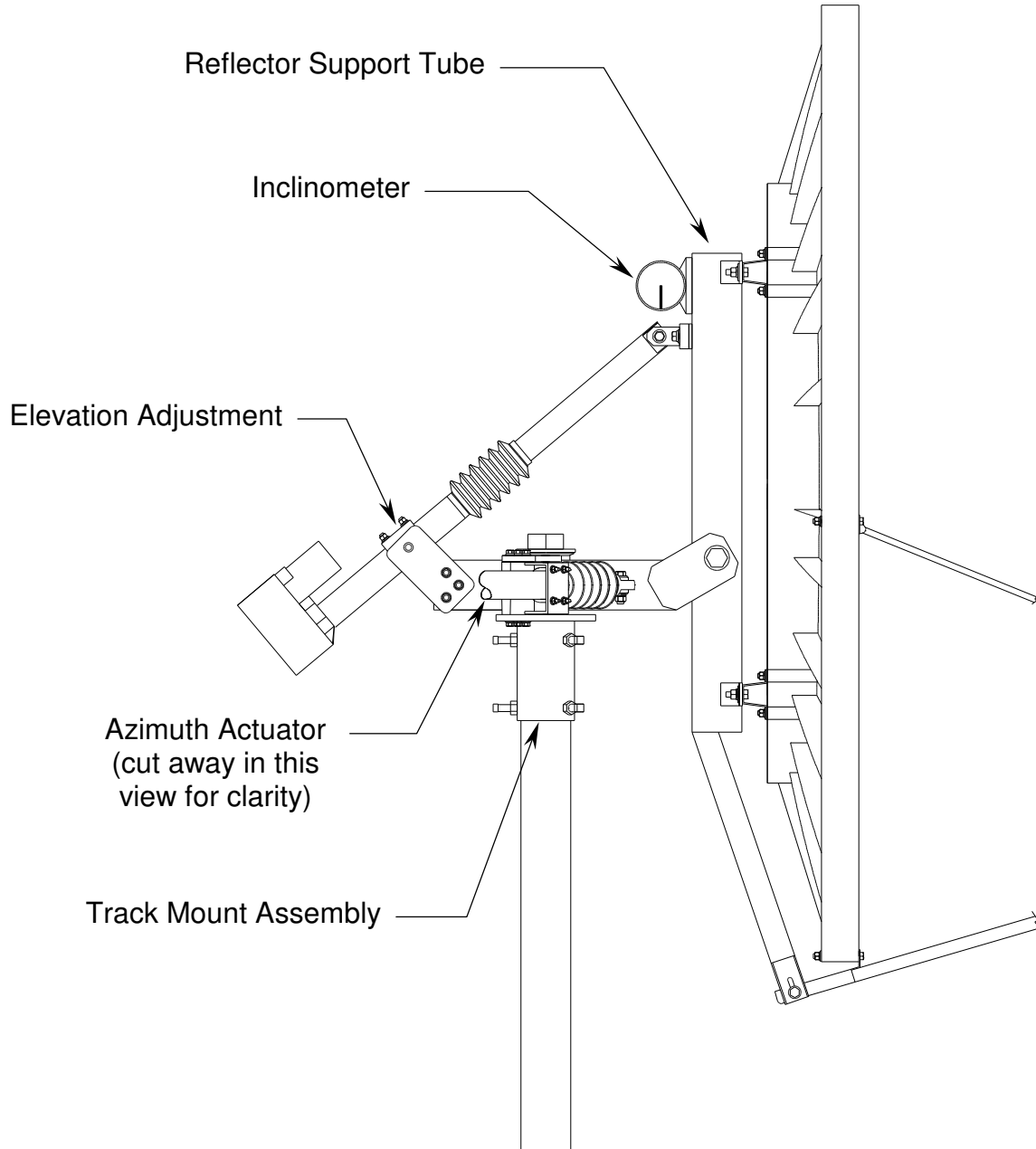


Figure 5

**SECTION VI        MAINTENANCE****6.0        MAINTENANCE OVERVIEW**

After installation, the antenna requires only periodic inspection. It is anticipated that maintenance, if required, will be minimal and easily handled by a local or in-house maintenance staff. The materials used in the construction of this Earth Station Antenna virtually eliminate any maintenance repairs.

**6.1        PERIODIC INSPECTION**

It is suggested that a periodic inspection be performed at least every six months.

NOTE: After any very severe weather conditions, inspection of the antenna should be performed to determine if foreign objects have caused damage or if survival specifications have been exceeded.

This inspection should include the following:

- 1)        Check all bolting locations - all bolts should be tight.
- 2)        Check all structural members - repair or replace if damaged.
- 3)        Check the foundation anchor bolts - they must be secure and with no failure signs in foundation.
- 4)        Check for corrosion - on the reflector structure and mount.

**6.2        REFLECTOR**

Prodelin's reflector does not require any maintenance. The composite construction of the reflector is virtually impervious to any damages that could be caused by weather or other atmospheric conditions.

It is only necessary to inspect for any physical damage done by vandalism or very severe weather conditions.

Should any damage be detected to a portion of the reflector, contact the Customer Service Department at Prodelin for recommendations involving reflector repair.

**6.3 MOUNT AND REFLECTOR SUPPORT STRUCTURE**

The mount and reflector support structure supplied with this antenna is of steel construction and has a hot-dipped galvanized finish.

If inspection shows any signs of structural failure, the mount members that are damaged should be repaired or replaced.

Corrosion: Any corrosion on steel members may be repaired with a cold, zinc-rich galvanizing paint.

**6.4 FEED AND FEED SUPPORT**

The feed support system should be inspected to insure that all hardware is secure. The feed/radio mounting bolts should be tight.

The feed horn window should be inspected to insure that it is intact so that no moisture can collect inside the feed horn. Replace if damaged.

**6.5 BEARINGS**

The bearings should be lubricated every six months by spraying a light oil on the bearings and allowing the oil to saturate onto the bearing.

**6.6 ACTUATORS**

The actuators are designed to provide years of maintenance free service. Although it might be a good to remove the motor housing covers and spray a light oil on the gears of the limit switches.