

**GENERAL DYNAMICS**

SATCOM Technologies

4096-476

May 13, 2009

Revision F

Assembly Manual

**2.4 METER  
SERIES 1251 ANTENNA SYSTEM**

General Dynamics SATCOM Technologies  
1500 Prodelin Drive  
Newton NC 28658

## 2.4 Meter 2 Piece Az/EI Installation Instructions

H	Revised Header and Installation Table	5/13/09	RAH
E	Revise Logo	4/16/09	RAH
D	Revised picture Page 22	10/15/02	CLT
C	Revised Address	1/21/02	CLT
B	Overall Update	11/21/97	PGW
A	Revised Hdw tables to reflect B.O.M	2/11/97	PGW
-	ORIGINAL RELEASE	4/10/96	RF
<b>REV.</b>	<b>DESCRIPTION</b>	<b>DATE</b>	<b>APPROVED</b>

**2.4M SERIES 1251 ANTENNA SYSTEM****TABLE OF CONTENTS**

<b><u>SECTION</u></b>	<b><u>TITLE</u></b>
<b>I</b>	<b>GENERAL INFORMATION</b>
1.0	INTRODUCTION
1.1	UNPACKING AND INSPECTION
1.2	MECHANICAL INSTALLATION TOOLS
1.3	SITE SELECTION
1.4	SUGGESTED MAST & FOUNDATION
<b>II</b>	<b>REFLECTOR AND SUPPORT ASSEMBLY</b>
2.0	PART LIST
2.1	AZ/EL POSITIONER INSTALLATION
2.2	REFLECTOR PETAL ORIENTATION
2.3	REFLECTOR SUPPORT ASSEMBLY
<b>III</b>	<b>FEED SUPPORT</b>
3.0	PART LIST
3.1	FEED SUPPORT INSTALLATION
<b>IV</b>	<b>ANTENNA POINTING</b>
4.0	ALIGNMENT TO SATELLITE
4.1	INITIAL ALIGNMENT
<b>V</b>	<b>MAINTENANCE</b>
5.0	MAINTENANCE OVERVIEW
5.1	PERIODIC INSPECTION
5.2	REFLECTOR
5.3	MOUNT AND REFLECTOR SUPPORT
5.4	FEED AND FEED SUPPORT

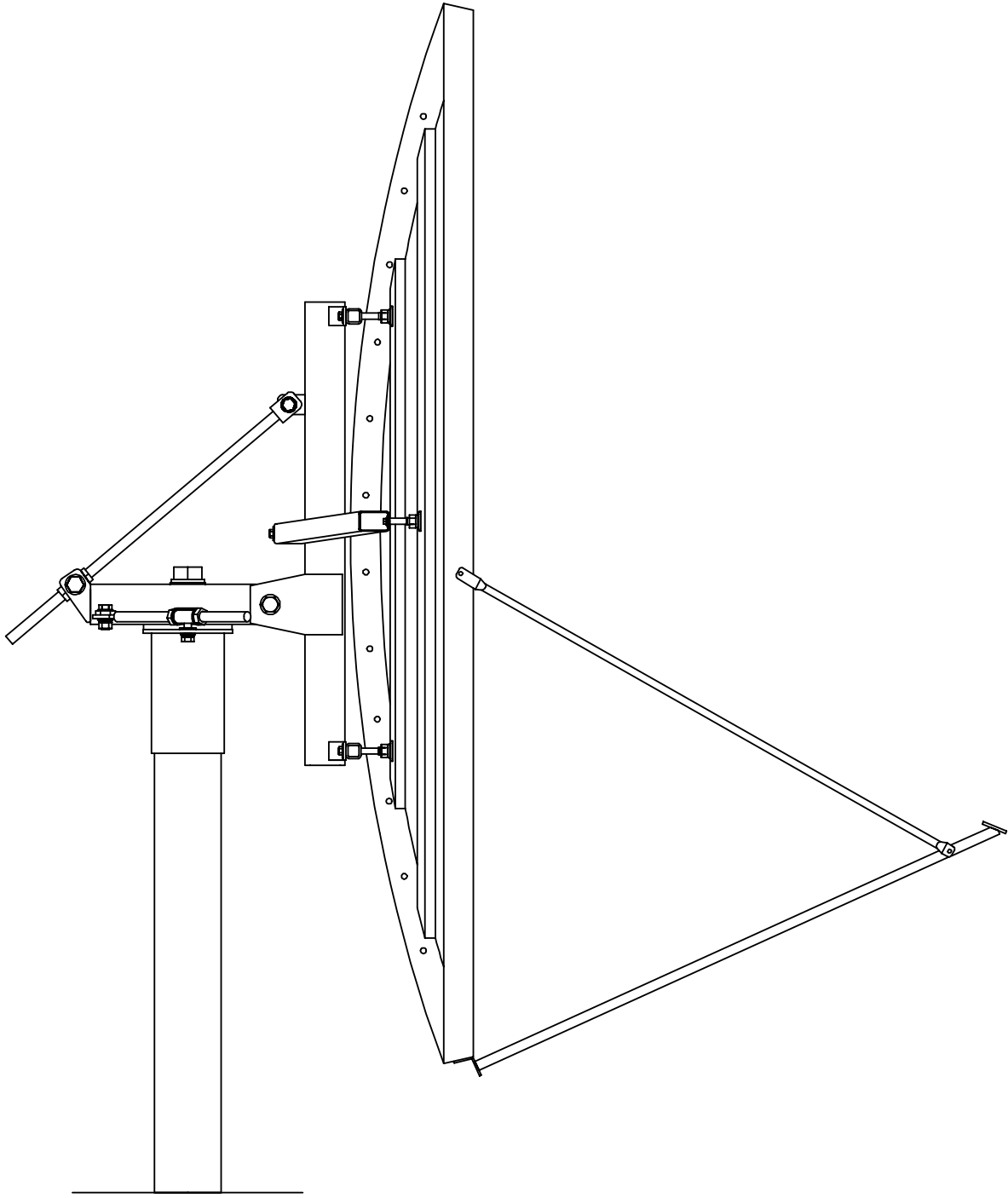

**SECTION I            GENERAL INFORMATION****1.0    INTRODUCTION**

This manual describes the assembly and installation of General Dynamics 2.4M 2-Piece Rx/Tx offset antenna system with an Az/EI mount (series number 1251). The General Dynamics 2.4M is a rugged, reliable antenna system that will operate at C-band and Ku-band frequencies with high efficiency and at the same time successfully withstand the effects of the environment.

These instructions are listed by sections that cover all areas of assembly and installation. Additional sections are included in the manual to provide information on antenna alignment to the satellite and maintenance.

**1.1    UNPACKING AND INSPECTION**

- 1.    UNPACKING & INSPECTION** - The antenna containers should be unpacked and inspected at the earliest date to ensure that all material has been received and is in good condition. A complete packing list for each major component is supplied.
  
- 2.    FREIGHT DAMAGE** - Any damage to materials while in transit should be immediately directed to the freight carrier. He will instruct you on the matters regarding any freight damage claims.
  
- 3.    MATERIAL - MISSING OR DAMAGED** - Any questions regarding missing or damaged materials that is not due to freight carrier should be directed to General Dynamics's Customer Service Department at:

**General Dynamics SATCOM Technologies  
1500 Prodelin Drive  
Newton NC 28658  
USA  
(828) 464-4141**

**1.2 MECHANICAL INSTALLATION TOOLS**

HARDWARE SIZE	SAE WRENCH SIZE	METRIC WRENCH SIZE	MAXIMUM REC. TORQUE
3 / 8"	9/16"	14 mm	20 ft-lbs
1 / 2"	3 / 4"	20 mm	40 ft-lbs
5 / 8"	15 / 16"	24 mm	70 ft-lbs
3 / 4"	1 – 1 / 8"	28 mm	145 ft-lbs
1"	1 – 1 / 2"	38 mm	220 ft-lbs

**NOTE: The Minimum Torque applied should not be less than 10% of maximum required torque listed in the table.**

Also recommended for installation:

Adjustable Wrench 10"  
Ratchet (3 / 8" & 1 / 2" Drive)  
3" Wrench ( socket, crescent or pipe) for 2" bolt  
Inclinometer  
Compass

**1.3 SITE SELECTION**

In order to achieve maximum performance of your antenna system, it is important to select the correct location for the antenna. The following guidelines should be observed when selecting a site for the installation.

1. The line of site to the satellite should be clear of any obstructions, such as trees or buildings.
2. The site should be relatively flat and level for ease of installation and access to the antenna.
3. The site should be checked for underground obstruction, such as buried cables or pipes.
4. All local building codes should be adhered to (i.e. grounding, foundation requirements, zoning rules, setbacks, etc.).

**1.4 SUGGESTED MAST & FOUNDATION**

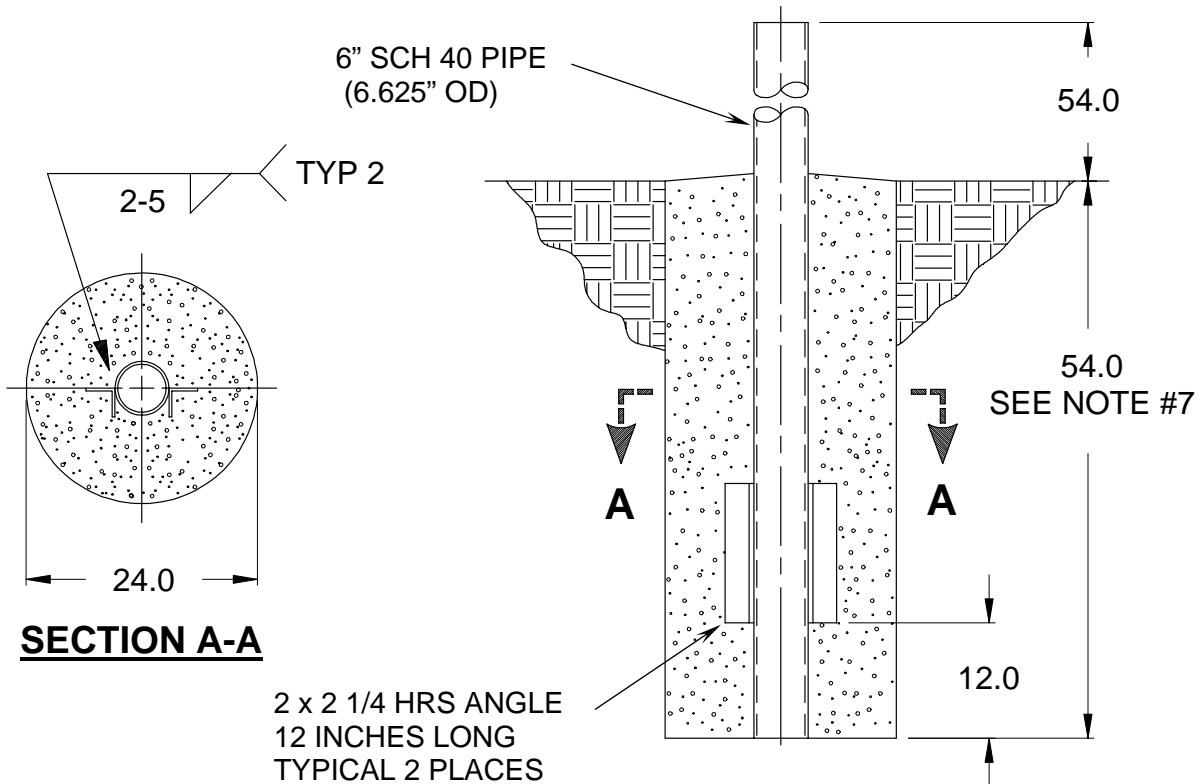

**NOTES:**

1. 2 x 2 x 1/4 HRS Angle and schedule 40 pipe should conform with ASTM A36 and ASTM A53 Type E and S Grade B.
2. All concrete should conform to building code standards and have a minimum compressive strength of 3000 PSI at 28 days. (Per ACI-318-77)
3. Soil bearing capacity should be no less than 2000 PSF.
4. Concrete should be poured against undisturbed soil.
5. Allow concrete 24 hours set time before installation of antenna.
6. The antenna should be properly grounded to meet applicable local codes.
7. Minimum depth as shown or extend to local frost line.
8. Foundation meets the design requirements as set forth by the uniform building code. (1982 edition)

(GENERAL DYNAMICS CORPORATION DOES NOT REPRESENT OR WARRANT THAT ANY PARTICULAR DESIGN OR SIZE OF FOUNDATION IS APPROPRIATE FOR ANY LOCALITY OR EARTH STATION INSTALLATION.)

**SECTION II      REFLECTOR AND SUPPORT ASSEMBLY**

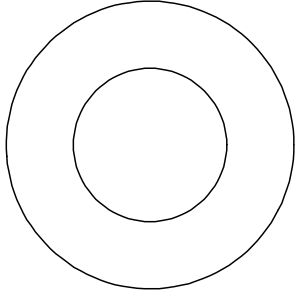
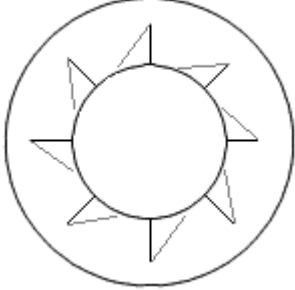
<b>REFLECTOR AND SUPPORT ASSEMBLY PART LIST- TABLE 2.0</b>			
<b>ITEM</b>	<b>PART NO.</b>	<b>DESCRIPTION</b>	<b>QTY</b>
1	0179-381 0179-383	REFLECTOR "A" SIDE REFLECTOR "A" SIDE – WITH SHC	1
2	0179-382 0179-384	REFLECTOR "B" SIDE REFLECTOR "B" SIDE – WITH SHC	1
3	0181-691	Az / EI POSITIONER ASSEMBLY	1
4	0159-283	THREADED INSERT	6
5	0490-601	SUPPORT TUBE	1
6	0250-657	TOP / BOTTOM CROSSARM	2
7	0181-249	ELEVATION ADJUSTMENT ASSEMBLY	1
8	0490-602	CROSSARM WELDMENT	1
9	8201-045	3/4 " FLATWASHER 	6
10	8200-015	3/4" LOCK WASHER INTERNAL TOOTH 	6

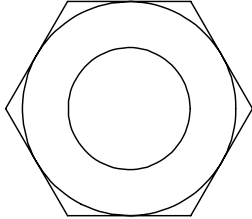
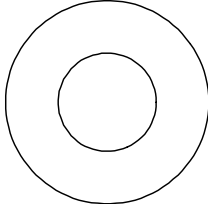
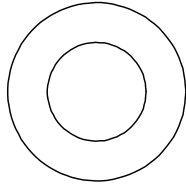
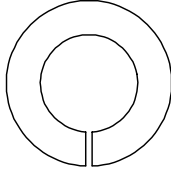
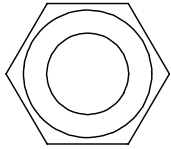
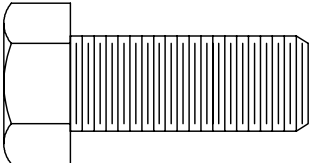
PARTS LIST - CONTINUED			
ITEM	PART NO.	DESCRIPTION	QTY
11	8106-007	3/4" HEX NUT 	6
12	8201-043	1/2" FLATWASHER 	12
13	8201-030	1/2" FLATWASHER - NARROW 	18
14	8202-043	1/2" LOCK WASHER 	15
15	8104-007	1/2" HEX NUT 	15
16	8033-010	1/2"-13 x 1.25 BOLT 	9

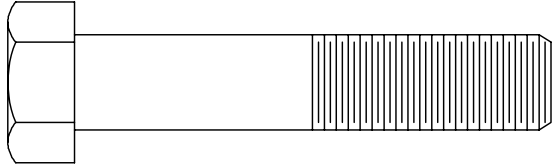
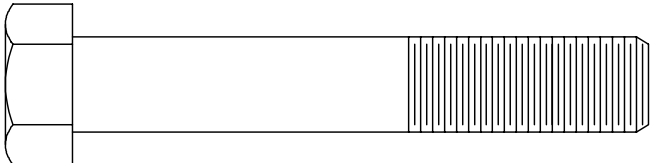
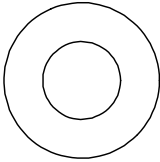
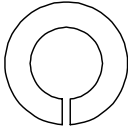
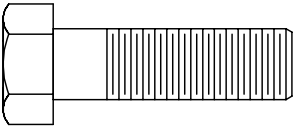
PARTS LIST - CONTINUED			
ITEM	PART NO.	DESCRIPTION	QTY
17	8033-021	1/2"-13 x 2.50 BOLT 	4
18	8033-032	1/2"-13 x 4.00 BOLT 	2
19	8201-042	3/8" FLATWASHER 	6
20	8202-042	3/8" LOCK WASHER 	6
21	8032-010	3/8"-16 x 1.25 HEX BOLT 	6

**CAUTION:** During the assembly procedure, the sequence of instructions must be followed. ***Do Not Tighten Any Hardware Until Instructed.*** Refer to the antenna assembly parts list and the following steps.

**2.1 Az / EI POSITIONER INSTALLATION****STEP 1:**

Back out the [8] 5/8" set screws from the canister and slip Az/EI positioner assembly over the mast pipe. Tighten the set screws snug against the mast pipe.

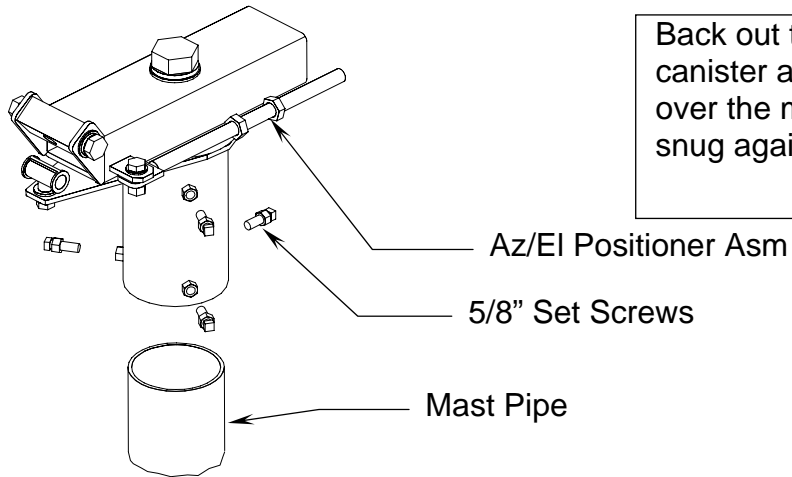
**STEP 2:**

- A) Loosen the 2" rotation bolt on top of the positioner.
- B) Rotate the positioner so that the canister plate is oriented as shown.
- C) Lightly tighten the 2" bolt.

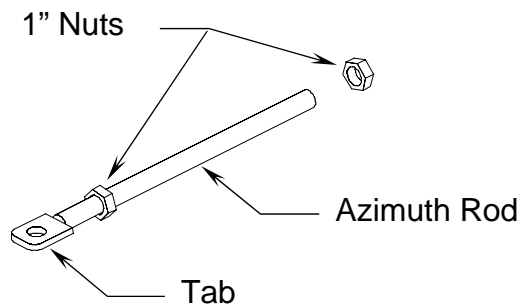
**STEP 3:**

- A) Remove the azimuth rod from the positioner.
- B) Run one of the 1" nuts up towards the tab end of the rod and remove the other 1" nut.

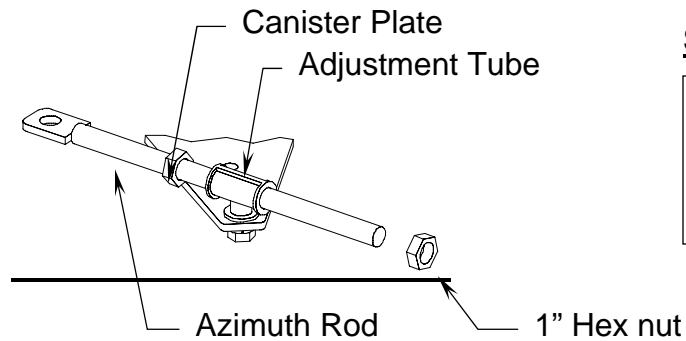
**STEP 4:**

Place the end of the azimuth rod thru the adjustment tube attached to the top of the canister plate and replace the 1" hex nut.

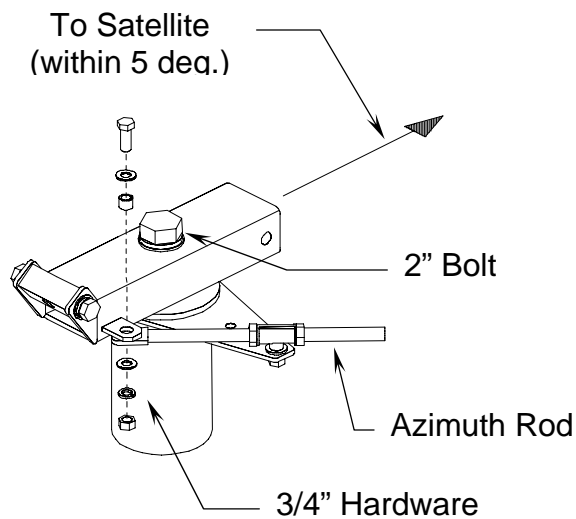
**STEP 5:**

- A) Re-attach the azimuth rod to the positioner with the 3/4" x 2.00 bolt flatwashers, lockwasher, sleeve and nut. Tighten securely. Snug the 2" rotation bolt at this time.
- B) The positioner must be oriented correctly to the center of the satellite orbital arc. Loosen the set screws and rotate the canister on the mast pipe to the required position. Tighten the set screws then tighten the 5/8" lock nuts against the canister.

## 2.2 REFLECTOR PETAL ORIENTATION

The series 1251 reflector petals are labeled “A” and “B”. In the standard upright position, the antenna elevation angle range is between 5 and 90 degrees. When viewed from behind in the standard position (feed support at the bottom), the “A” petal (item 1) is on the left side and the “B” petal (item 2) is on the right side – See Fig. 1.

However, to achieve a lower profile installation or in areas of high snow accumulation, the reflector can be assembled inverted (feed support on top) with the “B” petal on the left side and the “A” petal on the right side – See Fig. 2. Please note that in either situation, the angled cross arm (item 8) must be oriented for the correct position – See Fig. 3.

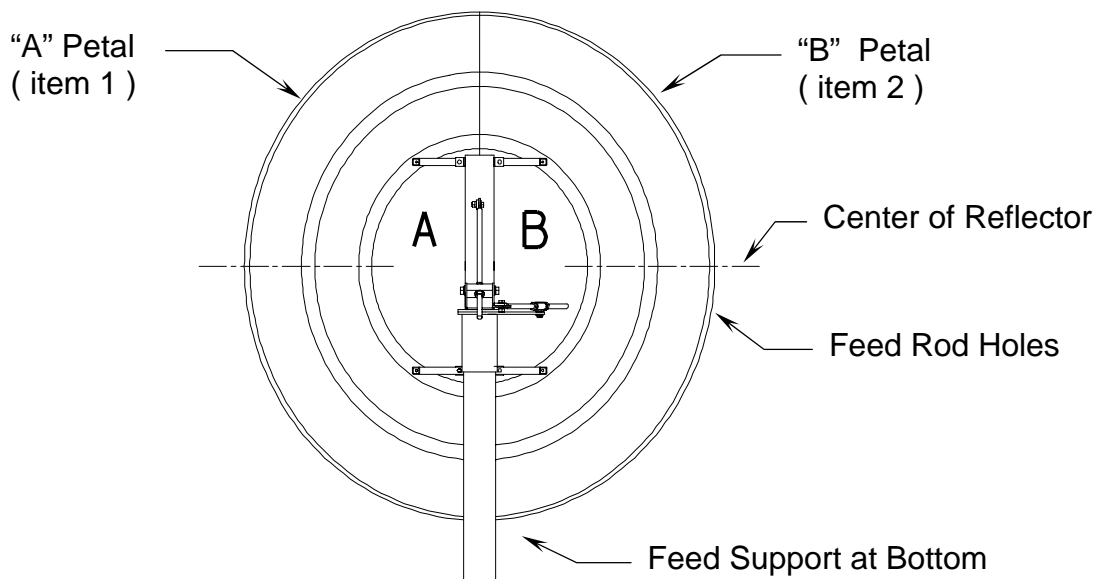

Figure 1

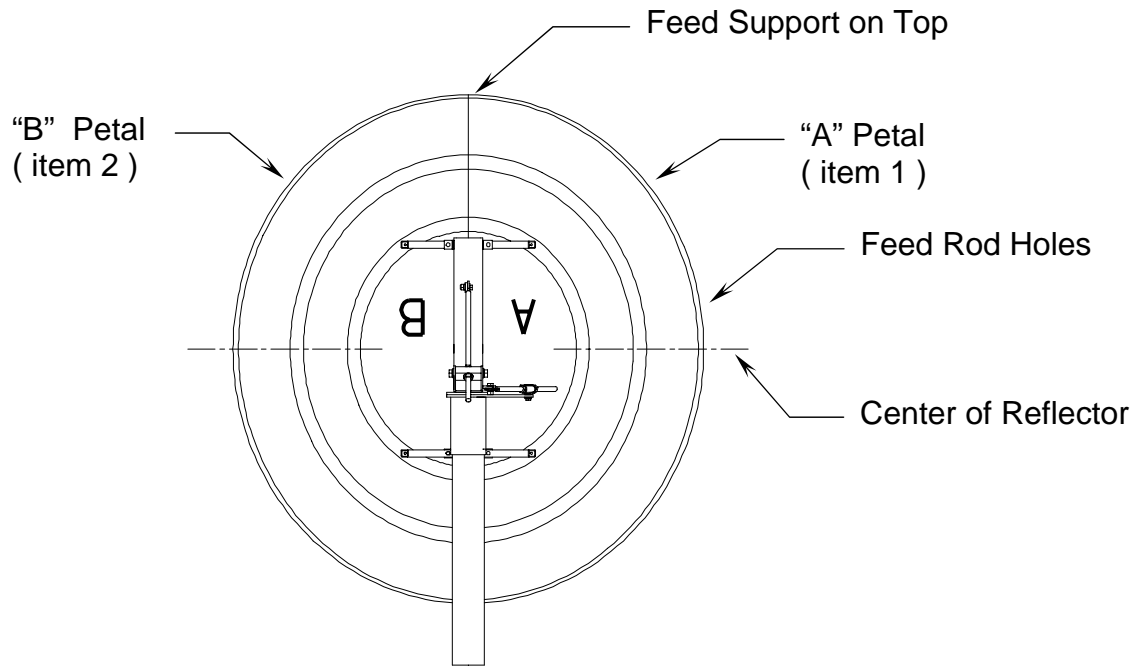

Figure 2

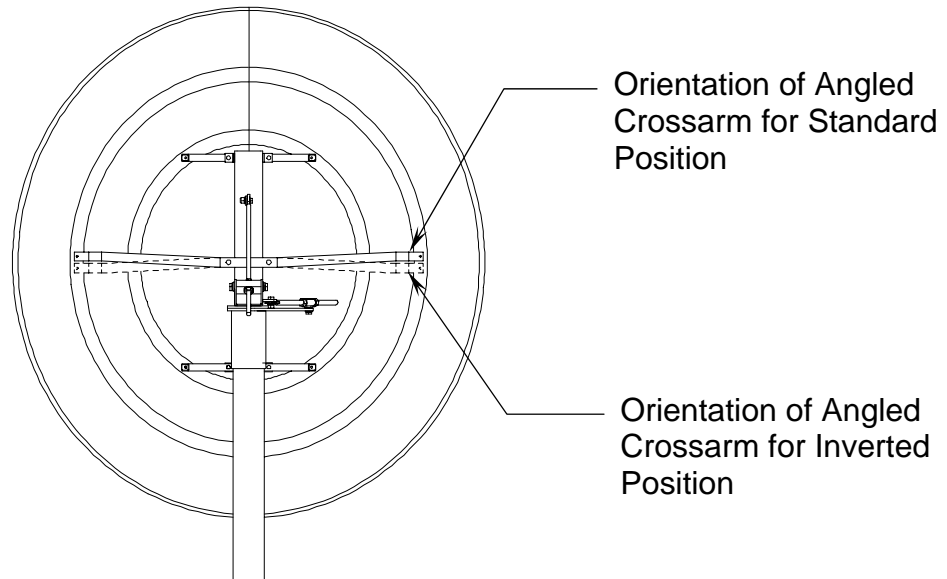
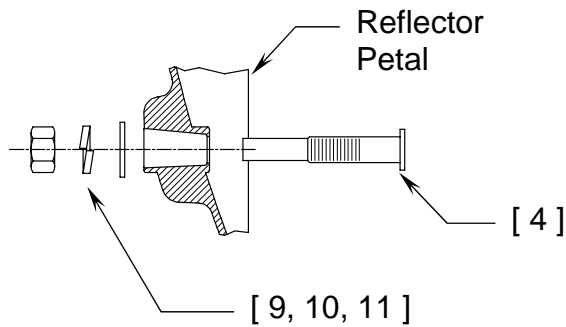
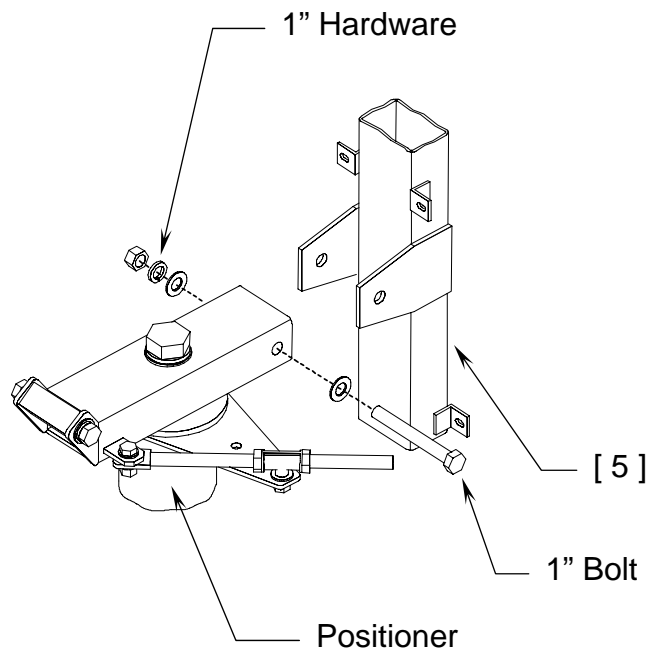

Figure 3

**2.3 REFLECTOR SUPPORT ASSEMBLY****STEP 1:**

Place three of the threaded inserts (item 4) thru the face of each reflector petal (items 1 & 2) and secure with 3/4" hardware (items 9, 10 & 11). Snug only, Do not completely tighten at this time.

**STEP 2:**

- A) Remove the 1" bolt and hardware from the Az/EI positioner.
- B) Straddle the tabs of the reflector tube (item 5) over the holes in the positioner and replace 1" bolt and hardware. Tighten snug only and let the tube fall back upon the positioner.

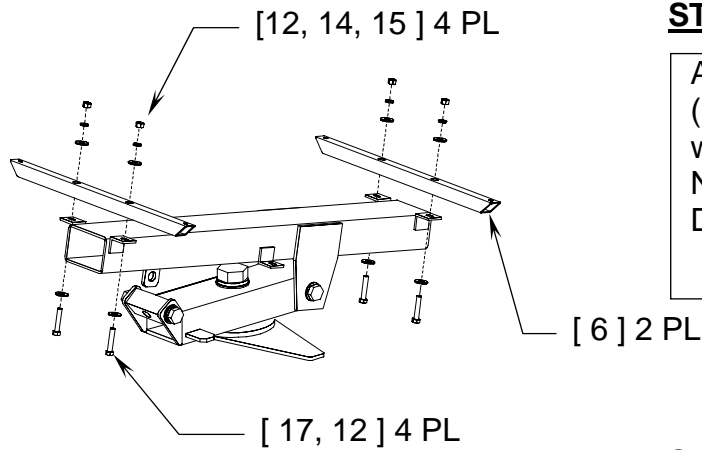

**STEP 3:**

Attach the top and bottom crossarms (item 6) to the reflector support tube with 1/2" hardware (items 12,14,15,17). Note orientation of crossarms. Do not tighten.

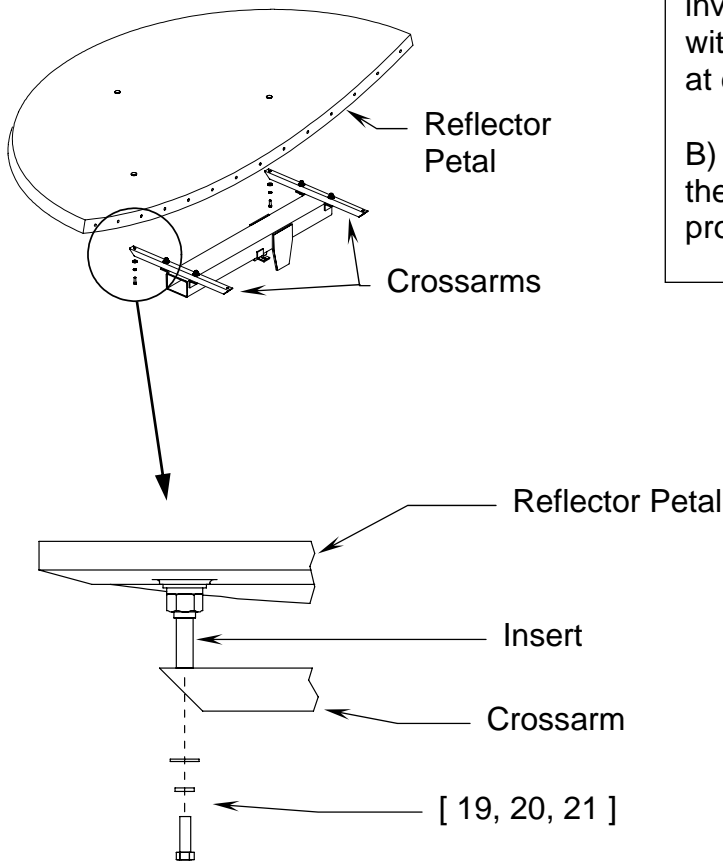

**STEP 4:**

A) Place one reflector petal onto the Cross arms in either the standard or inverted position – see 2.2. Attach with 3/8" hardware (items 19,20,21) at each crossarm. **Do not tighten**

B) Place the second reflector petal on the cross arms and repeat above procedure.

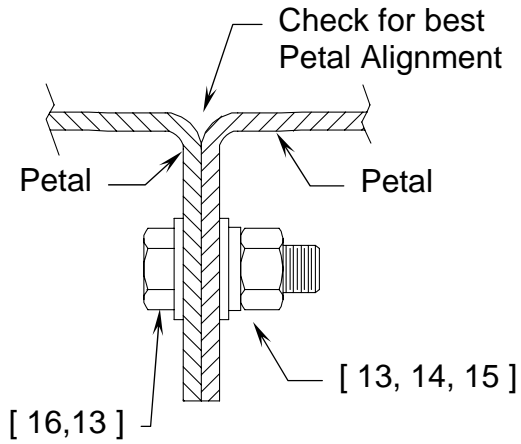

**STEP 5:**

Attach the two petals together with 1/2" hardware (items 13, 14, 15, 16) at the fourteen holes on the inner seams of the reflector petals. Tighten these bolts securely at this time while aligning the petals at the face of the reflector.

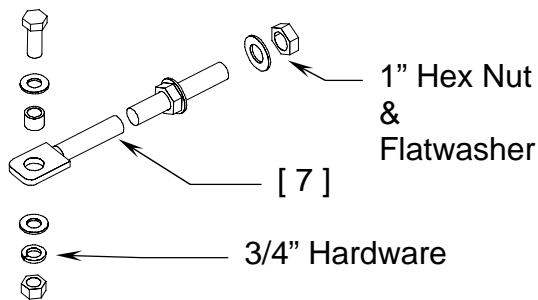

**STEP 6:**

Locate the elevation assembly (item 7) and remove the 3/4" hardware as well as one 1" hex nut and washer.

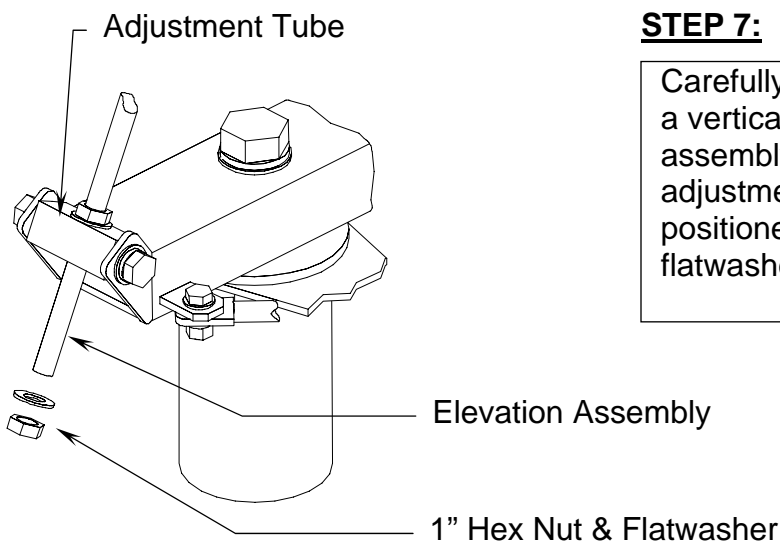

**STEP 7:**

Carefully swing the reflector up into a vertical position. Insert the elevation assembly (item 7) thru the elevation adjustment tube at the back of the positioner. Replace the 1" hex nut and flatwasher.

**STEP 8:**

Attach tabbed end of the elevation assembly to the tab on the back of the reflector support tube with the 3/4" hardware removed in step 6. Tighten securely.

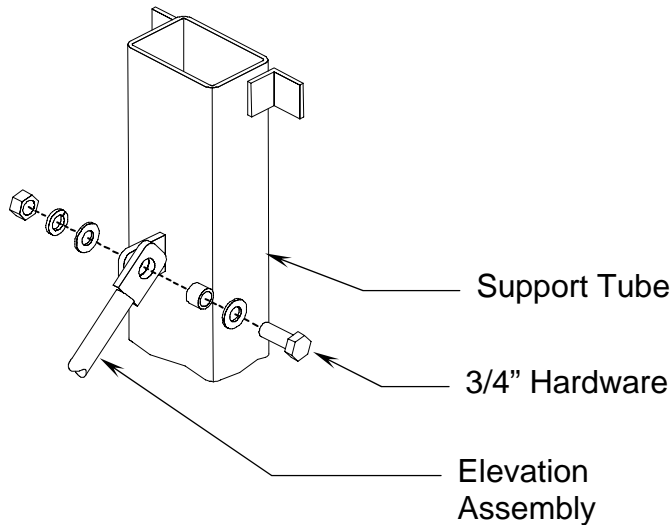

**STEP 9:**

- A) Attach the angled crossarm (item 8) to the reflector support tube in either the standard or inverted position depending on the reflector orientation with 1/2" hardware (items 12, 14, 15, 18).
- B) Attach the ends of the crossarm to the reflector petals at the threaded inserts with 3/8" hardware (items 19, 20, 21).
- C) Tighten the reflector support hardware by first tightening the 3/4" hardware at the six reflector inserts followed by the 3/8" bolts holding the reflector to the three crossarms. Next tighten six 1/2" bolts holding the crossarms to the reflector support tube. Do not tighten the elevation hardware until after satellite alignment.

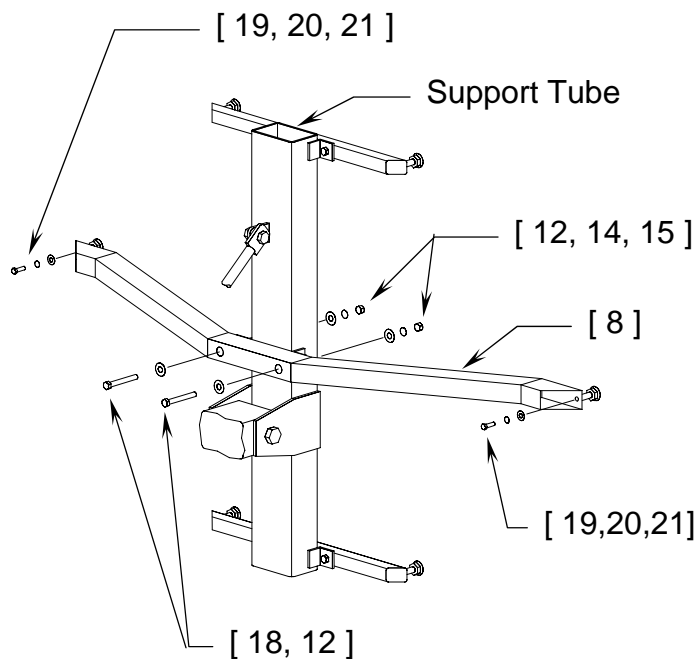

**SECTION III      FEED SUPPORT ASSEMBLY**

The following instructions are for installing a typical C-band or Ku-band feed support to General Dynamics's 2.4 meter antenna system.

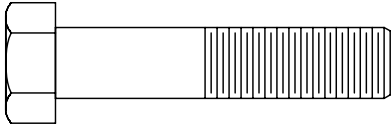
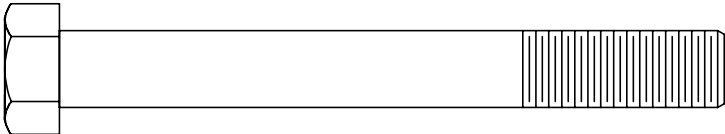
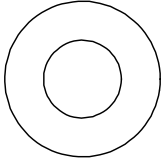
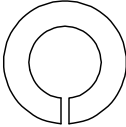
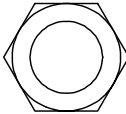
<b>FEED SUPPORT PART LIST- TABLE 3.0</b>			
<b>ITEM</b>	<b>PART NO.</b>	<b>DESCRIPTION</b>	<b>QTY</b>
1	VARIES	FEED SUPPORT	1
2	VARIES	FEED ROD – Ku BAND	2
3	VARIES	FEED ROD – C BAND	2
4	8032-014	3/8" x 1.75 BOLT 	4
5	8032-028	3/8" x 4.00 BOLT 	1
6	8201-042	3/8" FLATWASHER 	10
7	8202-042	3/8" LOCKWASHER 	5
8	8102-007	3/8" HEX NUT 	5

### 3.1 Feed Support Installation

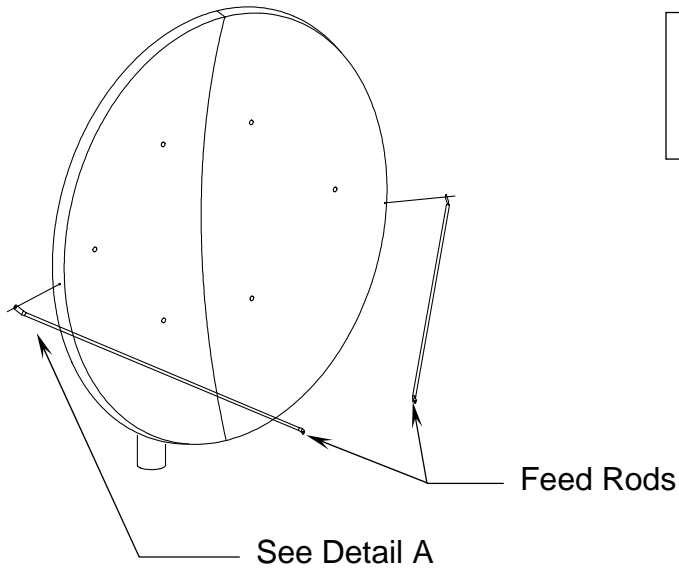

#### **STEP 1:**

Attach the feed rods loosely to the reflector with 3/8" hardware (items- 4, 6, 7 & 8 ). See detail A

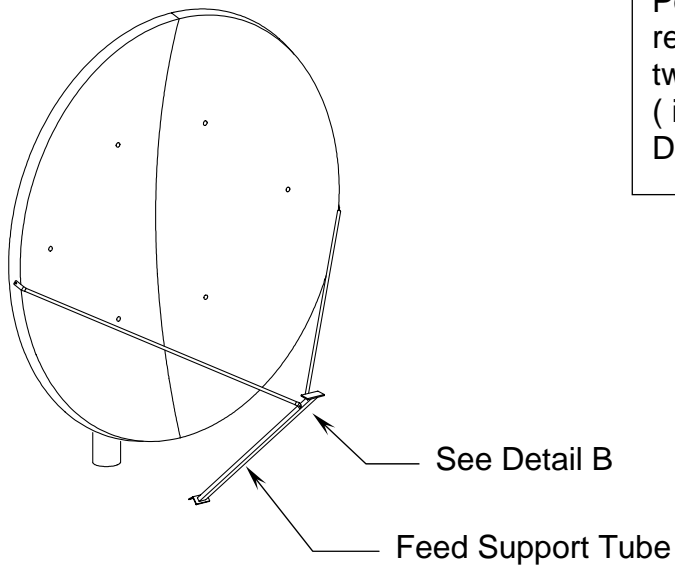

#### **STEP 2:**

Position the feed support in front of the reflector and attach to the ends of the two feed rods with 3/8" hardware ( items 5, 6, 7 & 8 ). See Detail B. Do not tighten.

**STEP 3:**

Lift the end of the feed support tube and attach to the bottom of the reflector with 3/8" hardware (items – 4, 6, 7 & 8). See Detail C.  
Tighten all feed support hardware at this time.

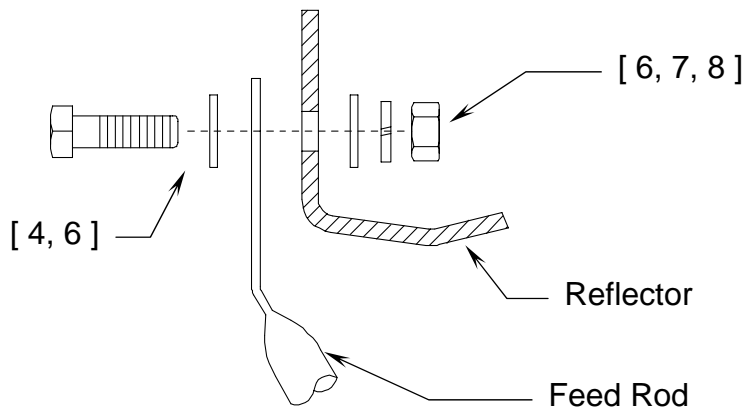
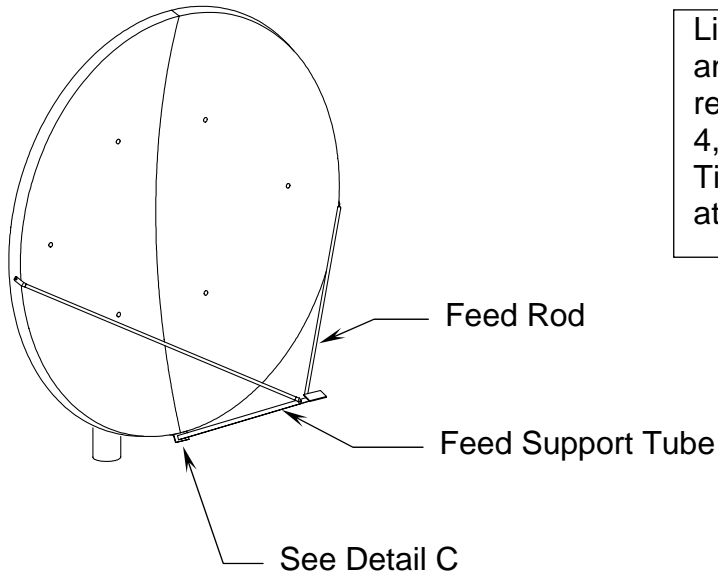

**DETAIL A**

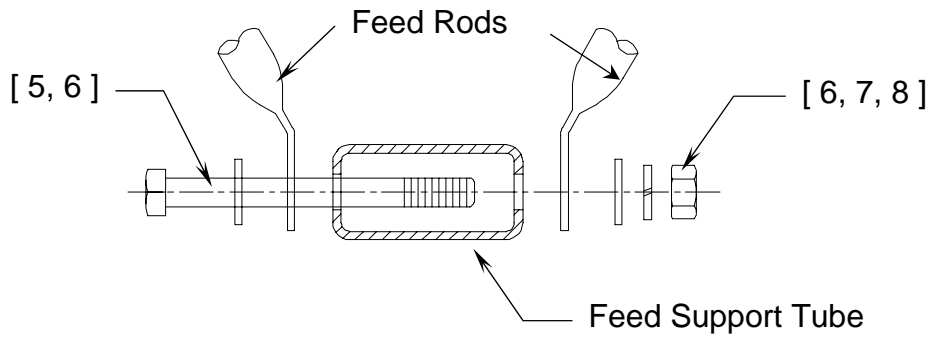

DETAIL B

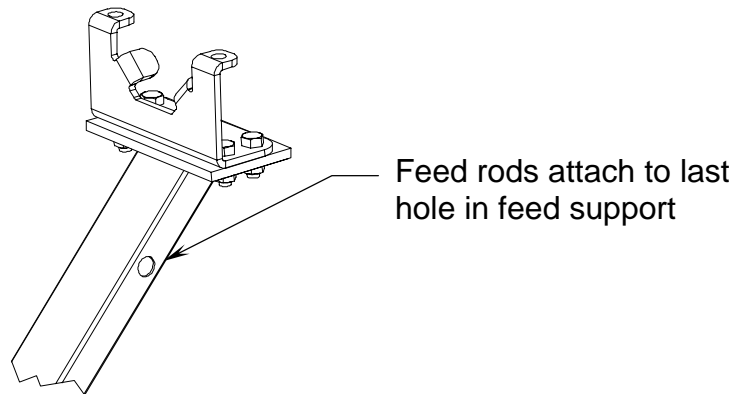

DETAIL C

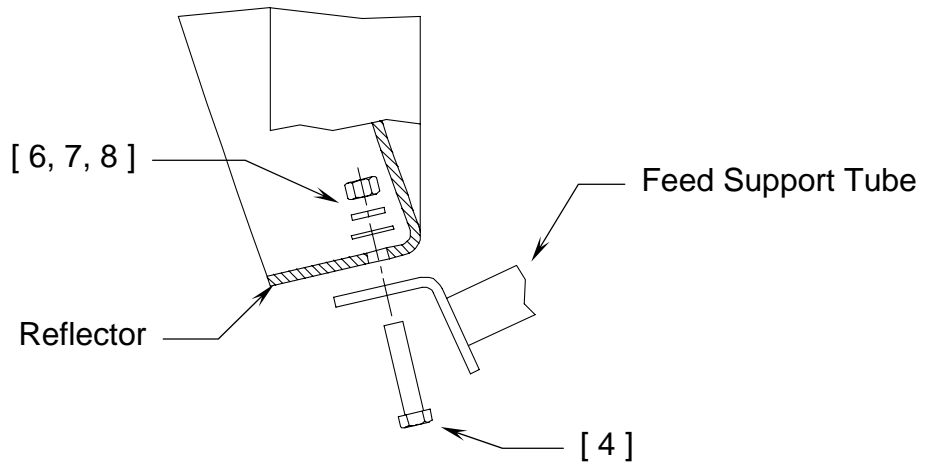

NOTE: At this time you are ready to install your C-band or Ku-band feed system. For feed installation, reference any instructions that are enclosed with your specific feed support.

**SECTION IV      ANTENNA POINTING****4.0      Alignment To Satellite**

The 2.4M offset reflector contains a 22.3° elevation offset angle. Therefore, when the reflector aperture is perpendicular to the ground, the antenna is actually looking 22.3° in elevation. The following alignment procedure is intended only as a general reference guide for this antenna. For proper antenna performance, accurate alignment is critical. Therefore, it is recommended that your own detailed procedure be used or contact General Dynamics's Technical Support Department for additional recommendations.

**4.1      Initial Alignment**

- 1) Place an inclinometer on the reflector support as shown in Figure 4. Remember to add 22.3 degrees to the reading to allow for the reflector's offset angle ( or subtract 22.3 degrees if inverted)
- 2) Raise or lower the antenna to find the desired elevation by turning the 1" nuts located at the elevation block. Position the top nut so that it will not interfere with adjustment. Turn the bottom nut clockwise to increase elevation and counterclockwise to decrease elevation.
- 3) After the correct elevation angle is set, rotate the antenna in azimuth by loosening the 1" nuts on the azimuth adjustment rod. Rotate azimuth until a signal is reached.
- 4) Peak the antenna signal by fine adjustments made in both azimuth and elevation.
- 5) Tighten all of the hardware used for adjustments.
- 6) Tighten 2" bolt.

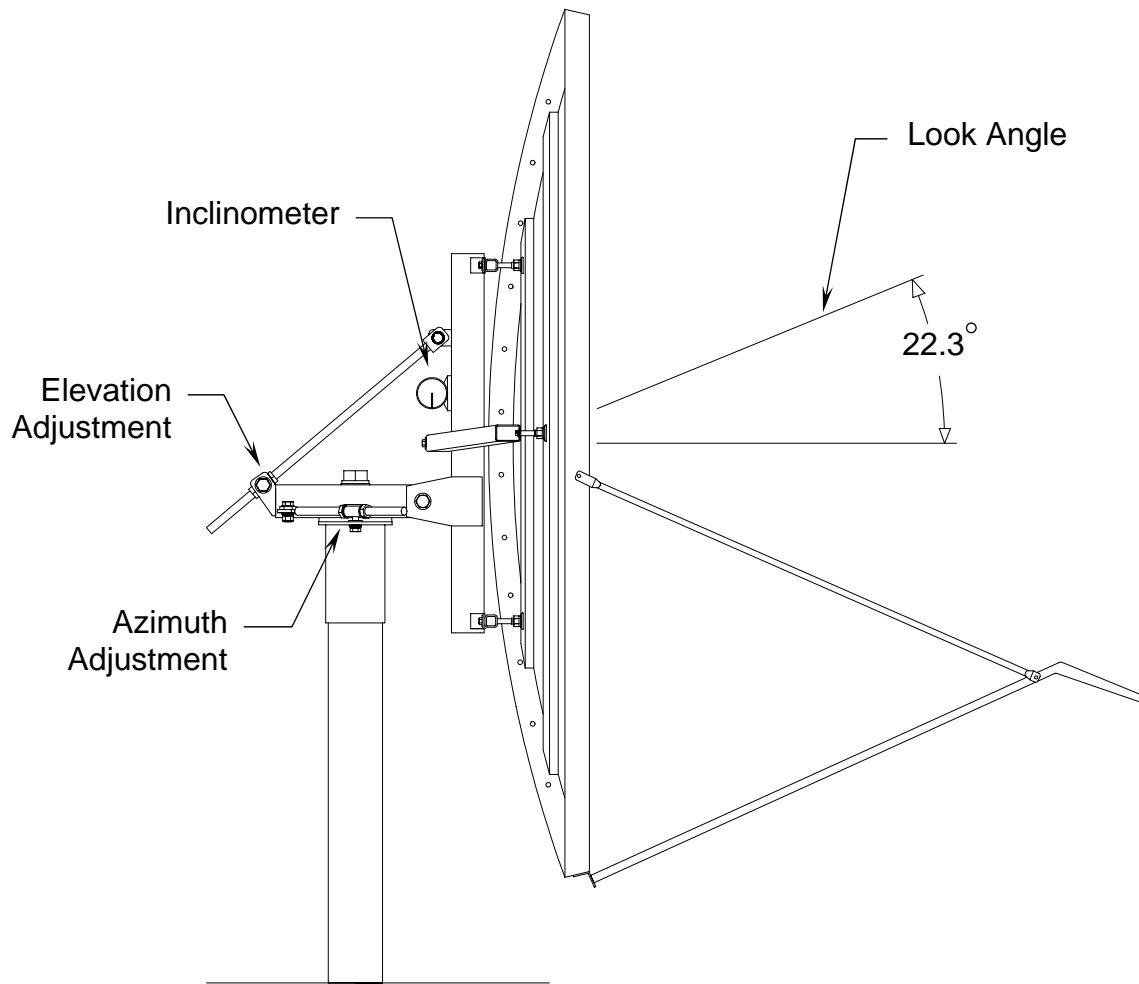

Figure 4

## SECTION V        MAINTENANCE

### 5.0    Maintenance Overview

After installation, the antenna requires only periodic inspection. It is anticipated that maintenance, if required, will be minimal and easily handled by a local or in-house maintenance staff. The materials used in the construction of this Earth Station Antenna virtually eliminate any maintenance repairs.

### 5.1    Periodic Inspection

It is suggested that a periodic inspection be performed at least every six months.

NOTE: After any very severe weather conditions, inspection of the antenna should be performed to determine if foreign objects have caused damage or if survival specifications have been exceeded.

This inspection should include the following:

- 1)    Check all bolting locations - all bolts should be tight.
- 2)    Check all structural members - repair or replace if damaged.
- 3)    Check the foundation anchor bolts - they must be secure and with no failure signs in foundation.
- 4)    Check for corrosion - on the reflector structure and mount.

### 5.2    Reflector

General Dynamics's reflector does not require any maintenance. The composite construction of the reflector is virtually impervious to any damages that could be caused by weather or other atmospheric conditions.

It is only necessary to inspect for any physical damage done by vandalism or very severe weather conditions.

Should any damage be detected to a portion of the reflector, contact the Customer Service Department at General Dynamics for recommendations involving reflector repair.

### 5.3 **Mount And Reflector Support Structure**

The mount and reflector support structure supplied with this antenna is of steel construction and has a hot-dipped galvanized finish.

If inspection shows any signs of structural failure, the mount members that are damaged should be repaired or replaced.

Corrosion: Any corrosion on steel members may be repaired with a cold, zinc-rich galvanizing paint.

### 5.4 **Feed And Feed Support**

The feed support system should be inspected to insure that all hardware is secure. The feed/radio mounting bolts should be tight.

The feed horn window should be inspected to insure that it is intact so that no moisture can collect inside the feed horn. Replace if damaged.

**GENERAL DYNAMICS**  
SATCOM Technologies

**4096-159**  
**REVISION G**  
**May 12, 2009**

**ASSEMBLY MANUAL**

**2.4M C-BAND Rx/Tx**  
**ANTENNA FEED SYSTEM**

**General Dynamics SATCOM Technologies**  
**1500 PRODELIN DRIVE**  
**NEWTON NC 28658**

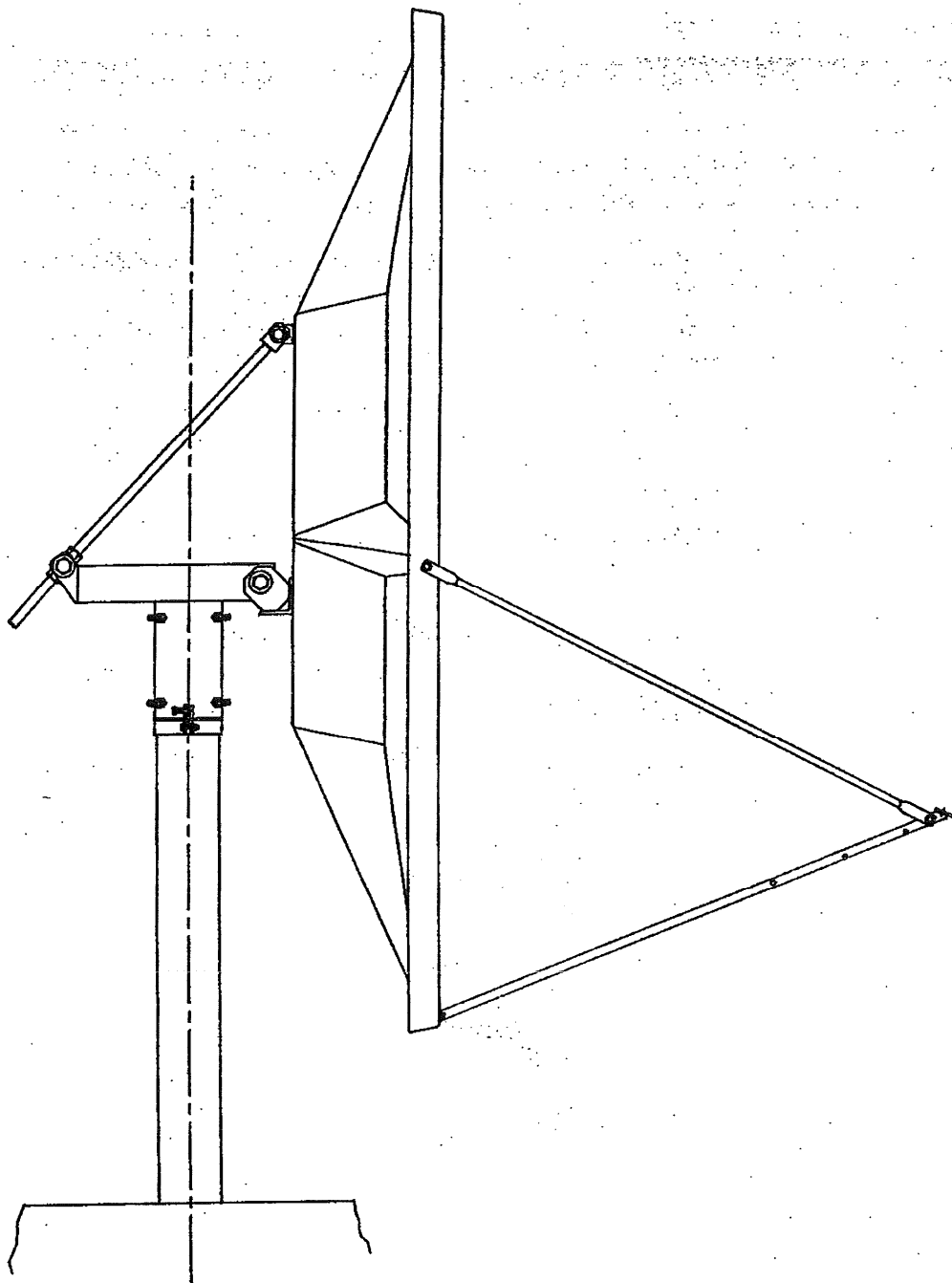

# 2.4M C-BAND Rx/Tx ANTENNA FEED SYSTEM

G	Revised Logo, name, and part numbers	5/12/09	RAH
F	Revise Text page 11	9/11/02	RAH
E	Revise Parts List - Feed Sprt table to match BOM	2/11/97	PGW
D		8/4/92	RF
-	ORIGINAL RELEASE	3/5/91	RF
<b>REV.</b>	<b>DESCRIPTION</b>	<b>DATE</b>	<b>APPROVED</b>

**TABLE OF CONTENTS**

<b><u>SECTION</u></b>	<b><u>TITLE</u></b>
<b>I</b>	<b>INTRODUCTION</b>
1.0	GENERAL INFORMATION
<b>II</b>	<b>FEED SUPPORT SYSTEM</b>
2.0	FEED SUPPORT ASSEMBLY
2.1	FEED ASSEMBLY
2.2	LNA/LNB ATTACHMENT
<b>III</b>	<b>FEED ASSEMBLY</b>
3.1	CROSS-POL & CO-POL
3.2	CIRCULAR POLARIZATION

## SECTION I INTRODUCTION

### 1.0 GENERAL INFORMATION

This manual describes the assembly and installation of General Dynamics' C-Band Rx/Tx Feed System. The General Dynamics C-Band Rx/Tx Feed System is a rugged, reliable antenna system, which will operate in the 3.7 to 6.425 GHz frequency bands with high efficiency and at the same time successfully withstand the effects of the environment.

## SECTION II FEED SUPPORT ASSEMBLY

### 2.0 FEED SUPPORT ASSEMBLY

As shown in figure 2.0-1, assemble the following items in the listed sequence. Do not tighten any hardware until step 4.

- Step 1: Attach a feed rod (item# 2) to each side of the reflector using a 3/8-16 x 1.25" bolt, [2] flatwashers, [1] lockwasher, and [1] hex nut (item# 3,5,6,7) for each rod. See detail "A".
- Step 2: Attach the other end of each feed rod to the feed support tube (item# 1) with the 3/8-16 x 3.00" bolt, [2] flatwashers, [1] lockwasher and [1] hex nut (item# 4,5,6,7). See detail "B".
- Step 3: Attach the feed support tube to the bottom of the reflector with [2] 3/8-16 x 1.25" bolts, [4] flatwashers, [2] lockwashers, and [2] hex nuts (item# 3,5,6,7). See detail "C".
- Step 4: Tighten all feed support hardware securely at this time.

PARTS LIST - FEED SUPPORT ASSEMBLY			
ITEM#	PART#	DESCRIPTION	QTY
1	Varies	FEED SUPPORT TUBE	1
2	Varies	FEED ROD	2
3	8032-010	BOLT, 3/8-16 x 1.25"	4
4	8032-024	BOLT, 3/8-16 x 3.00"	1
5	8201-042	FLATWASHER, 3/8"	8
6	8202-042	LOCKWASHER, 3/8"	5
7	8102-007	NUT, HEX, 3/8-16	5

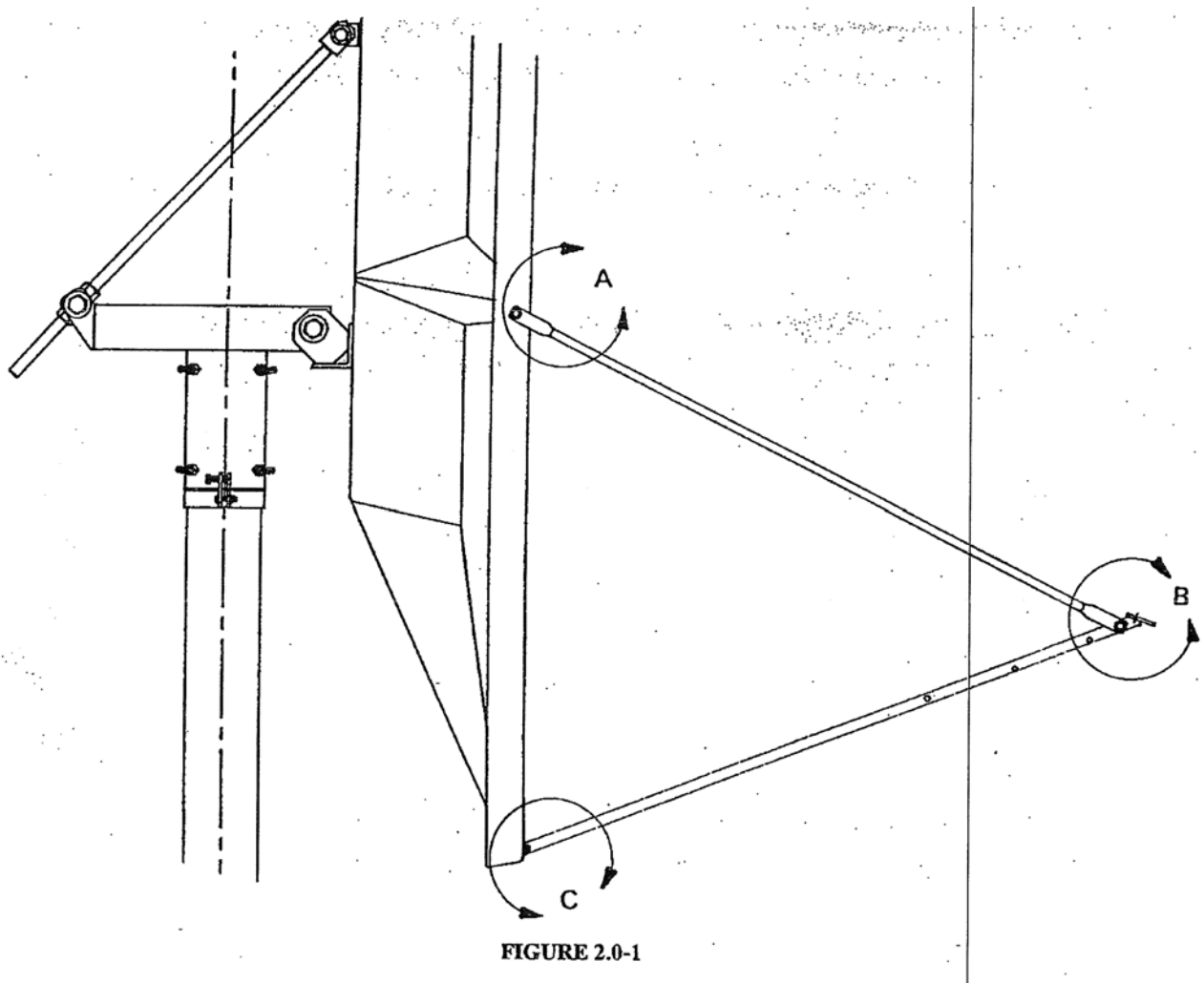

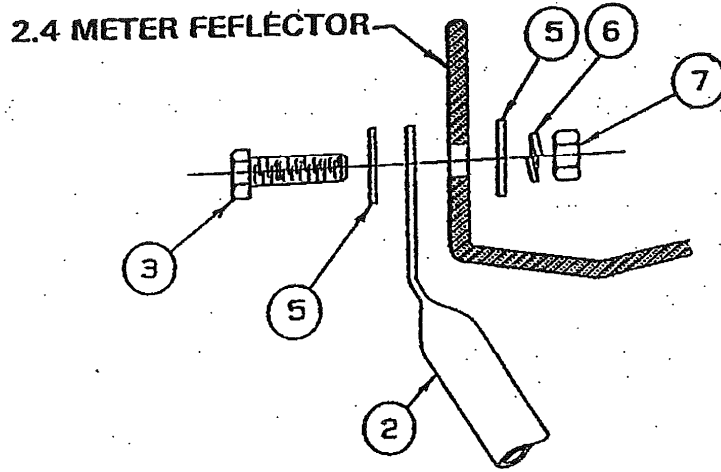

DETAIL A

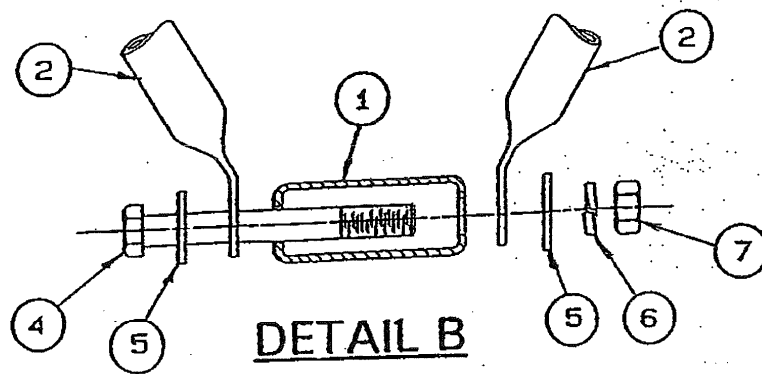

DETAIL B

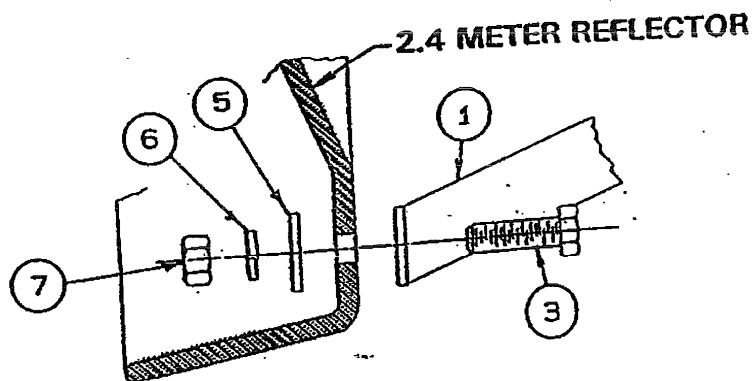

DETAIL C

## 2.1 FEED ASSEMBLY

**NOTE:** General Dynamics' 2.4 Rx/Tx antenna system is available with either Cross-Pol, Co-Pol, or Circular Polarization. Assembly of each feed configuration is outlined.

### 2.1-A CROSS-POL AND CO-POL FEEDS

Step 1: Apply silicone grease to the o-ring (item# 6) and place it in the groove in the OMT to be used. Mount the feed horn (item# 1) to the cross-pol OMT (item# 2) or co-pol OMT (item# 3) with [8] #10-24 x 1.25 screws, [16] #10 flatwashers, [8] #10 lockwashers, and [8] #10-24 hex nuts (item# 7,8,9,10). Tighten securely. **NOTE: The screws should be inserted from the feed horn side to prevent any interference.** See figure 2.1-A

Step 2: Attach the bottom feed mounting bracket (item# 4) to the feed support tube with [4] 3/8-16 x 1.25" bolts, [4] lockwashers, and [4] 3/8-16 hex nuts (item# 11,12,13). Tighten securely.

Step 3 : Place the neck of the feed horn/OMT assembly from step #1 into the feed mounting bracket and secure with the top feed mounting bracket (item# 5) using [2] 5/16-18 x 1.00" bolts, [2] lockwashers, and [2] 5/16-18 hex nuts (item# 14,15,16).

PARTS LIST - CROSS-POL & CO-POL			
<u>ITEM#</u>	<u>PART#</u>	<u>DESCRIPTION</u>	<u>QUANTITY</u>
1	0183-317	FEED HORN	1
2	0183-340	CROSS-POL OMT	1
3	0183-341	CO-POL OMT	1
4	0211-420	FEED MOUNTING BRACKET	2
5	0211-419	FEED MOUNTING BRACKET-TOP	2
6	0198-124	O-RING	2
7	302-007	#10-24 X 1.25 SCREW	8
8	8202-032	#10 LOCKWASHER	8
9	8111-005	#10-24 HEX NUT	8
10	8201-037	#10 FLATWASHER	16
11	8032-010	3/8-16 X 1.25" BOLT	4
12	8202-042	3/8" LOCKWASHER	4
13	8102-007	3/8-16 HEX NUT	4
14	8031-008	5/16-18 X 1.00" BOLT	2
15	8202-041	5/16" LOCKWASHER	2
16	8101-009	5/16-18 HEX NUT	2

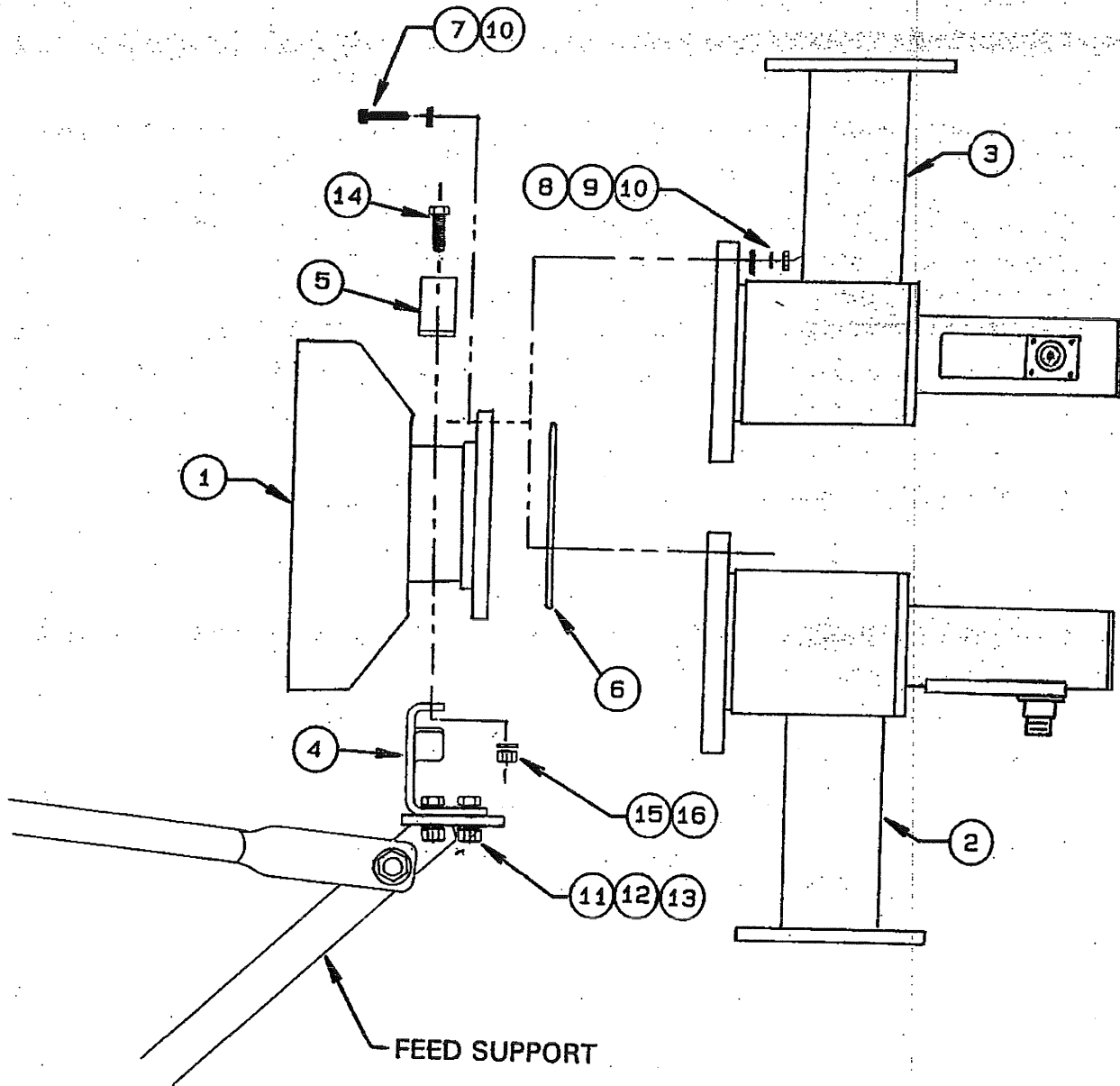

FIGURE 2.1-A

## 2.1-B CIRCULAR POLARIZATION

- Step 1: Apply silicone grease to [2] o-rings (item# 7) and place [1] in the o-ring groove in the circular polarizer (item# 3). Attach the feed horn (item# 1) to the circular polarizer (end with o-ring) with [8] #10-24 x 1.25" screws, [16] flatwashers, [8] lockwashers, and [8] #10-24 hex nuts (item# 8,9,10,11). Tighten securely. **NOTE: The screws should be inserted from the feed horn side to prevent any interference.** See figure 2.1-B.
- Step 2: Bolt the OMT (item# 2) to the circular polarizer by placing the remaining O-ring in the groove of the OMT and fastening it to the circular polarizer with [8] #10-24 x 1.25" screws, [16] flatwashers, [8] lockwashers, and [8] #10-24 hex nuts (item# 8,9,10,11). **NOTE:** The screws should be inserted from the circular polarizer side to prevent interference. For left hand polarization, align the "LHCP" on the flange of the circular polarizer with the arrow on the OMT. For right hand polarization, align the "RHCP" with the arrow on the OMT. Tighten securely. **NOTE:** When a polarization setting is attempted, installers should keep in mind that right hand and left hand polarization refers to the transmission of signals from the feed to the reflector. Then the reflector reverses the signal. Therefore a "LHCP" feed system results in an antenna system that transmits a Right Hand Circular Polarized signal.
- Step 3: Attach [1] bottom feed mounting bracket (item# 4) and the circular polarizer bracket (item# 6) to the feed support tube plate with [4] 3/8-16 x 1.25" bolts, [4] lockwashers, and [4] hex nuts (item# 13,14,15) through the feed mounting bracket, circular polarizer and feed support, as shown, and [1] 5/16-18 x 3.25" bolt, [1] lockwasher, and [1] hex nut (item# 18,19,20) through the circular polarizer bracket and feed support tube only. Tighten securely.
- Step 4: Attach the remaining bottom feed mounting bracket to the circular polarizer bracket with [4] 3/8-16 x 1.00" bolts, [4] lockwashers, and [4] 3/8-16 hex nuts (item# 12,14,15). Do not tighten. **NOTE: Refer to figure 2.1-B to be sure that the brackets are oriented correctly.**
- Step 5: Place the feed assembly from step #1 into the brackets and secure by fastening [1] top feed mounting bracket (item# 5) over the neck of the feed horn with [2] 5/16-18 x 1.00" bolts, [2] lockwashers, and [2] hex nuts (item# 16,19,20). Fasten the remaining top feed mounting bracket over the neck of the circular polarizer with [2] 5/16-18 x 1.50" bolts, [2] lockwashers, and [2] hex nuts (item# 17,19,20). Tighten the feed mounting bracket (from step #4) to the circular polarizer bracket. The antenna system is now ready to be aligned to the satellite.

<b>PARTS LIST</b>			
<b>CIRCULAR POLARIZATION</b>			
<b><u>ITEM NO.</u></b>	<b><u>PART NO.</u></b>	<b><u>DESCRIPTION</u></b>	<b><u>QUANTITY</u></b>
1	0183-317	FEED HORN	1
2	0183-341	CROSS-POL OMT	1
3	0182-191	CIRCULAR POLARIZER	1
4	0211-420	FEED MOUNTING BRACKET	2
5	0211-419	FEED MOUNTING BRACKET- TOP	2
6	0181-719	CIRCULAR POLARIZER BRACKET	1
7	0198-124	O-RING	2
8	8302-007	#10-24 X 1.25" SCREW	16
9	8202-032	#10 LOCKWASHER	16
10	8111-005	#10-24 HEX NUT	16
11	8201-037	#10 FLATWASHER	32
12	8032-008	3/8-16 X 1.00" BOLT	4
13	8032-010	3/8-16 X 1.25" BOLT	4
14	8202-042	3/8" LOCKWASHER	8
15	8102-007	3/8-16 HEX NUT	8
16	8031-008	5/16-18 X 1.00" BOLT	2
17	8031-012	5/16-18 X 1.50" BOLT	2
18	8031-026	5/16-18 X 3.25" BOLT	1
19	8202-009	5/16" LOCKWASHER	5
20	8101-009	5/16-18 HEX NUT	5

### CIRCULAR POLARIZATION

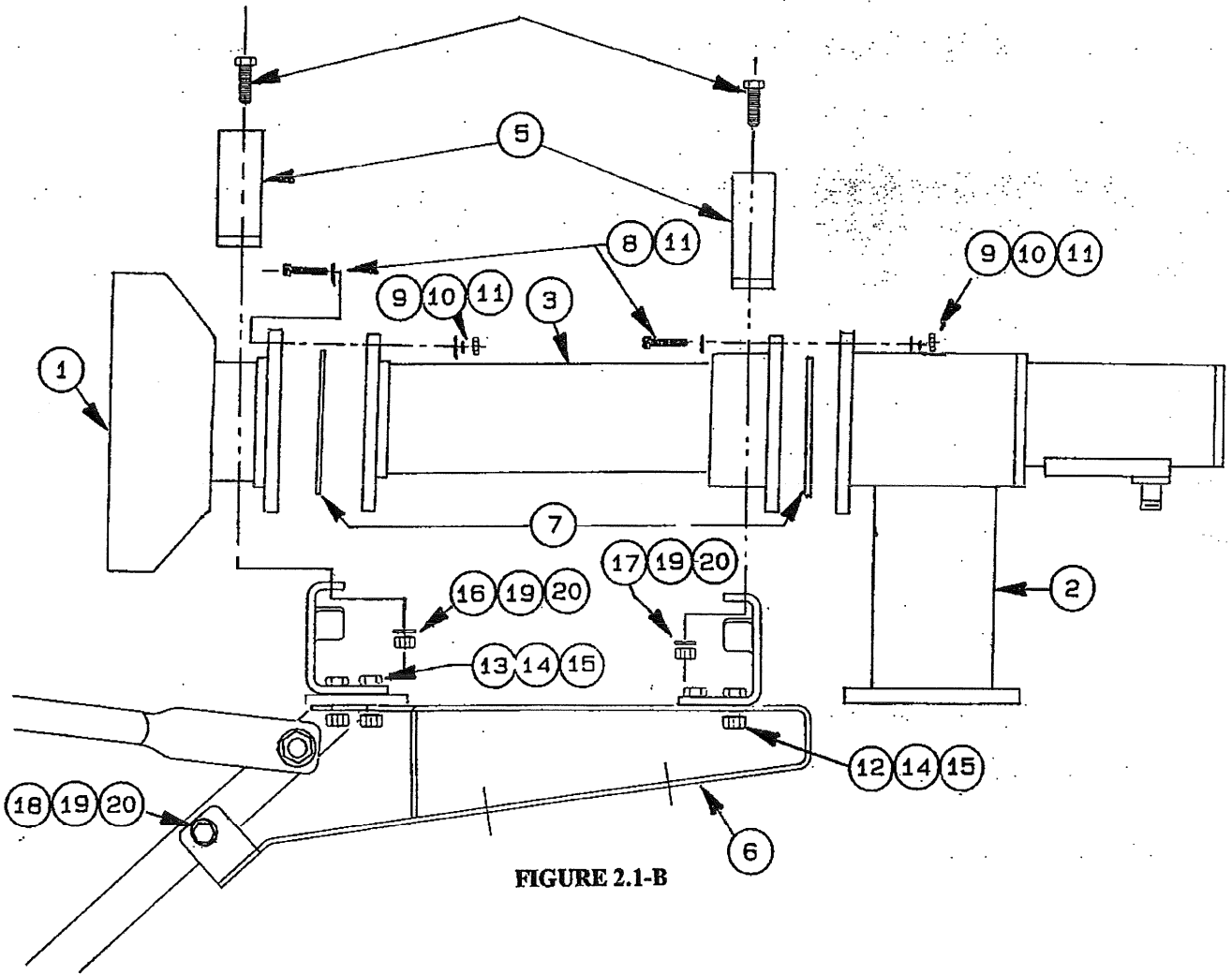
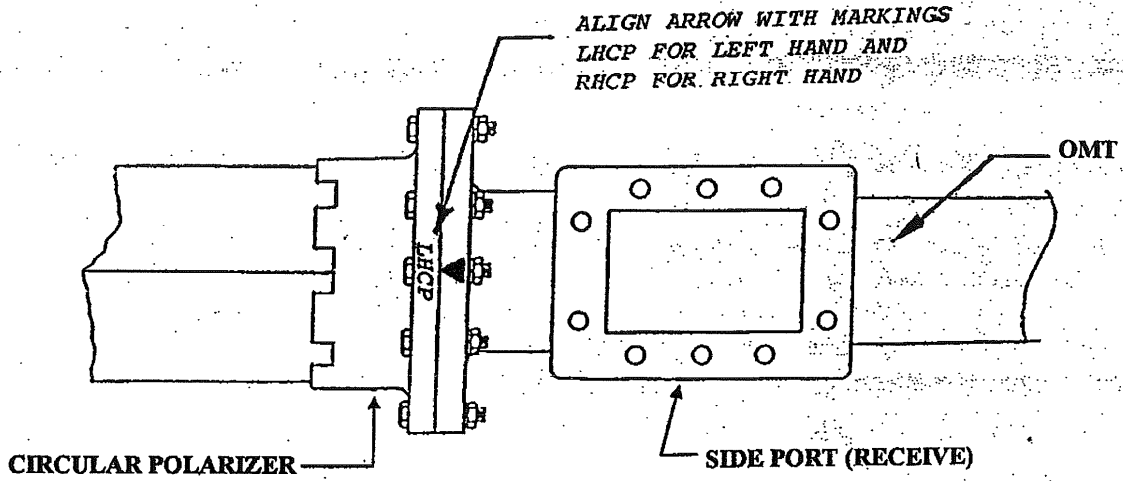

FIGURE 2.1-B

**2.2 LNB/LNA ATTACHMENT**

**STEP 1.** Apply silicone grease to gasket (item#1) and place gasket in groove in flange of LNA/LNB (customer supplied).

**STEP 2.** Attach LNA/LNB to side port (Rx) flange of OMT with (10) 1/4-20 x 1.00" bolts, (10) 1/4" flatwashers, (10) 1/4" lockwashers, and (10) 1/4-20 hex nuts (item# 2,3,4,5).

**STEP 3.** Tighten 1/4" hardware securely.

PARTS LIST - FEED SUPPORT ASSEMBLY			
ITEM#	PART#	DESCRIPTION	QTY
1	0171-073	GASKET, CPR WR2296 FLANGE HALF-THICK	1
2	8023-008	BOLT, 1/4-20 X 1.00" TYPE 304 S.S. STD.	10
3	8201--36	FLATWASHER, 1/4" S.S. STD.	10
4	8202-031	LOCKWASHER, 1/4" S.S. STD.	10
5	8100-005	NUT, HEX, 1/4-20 S.S. STD.	10

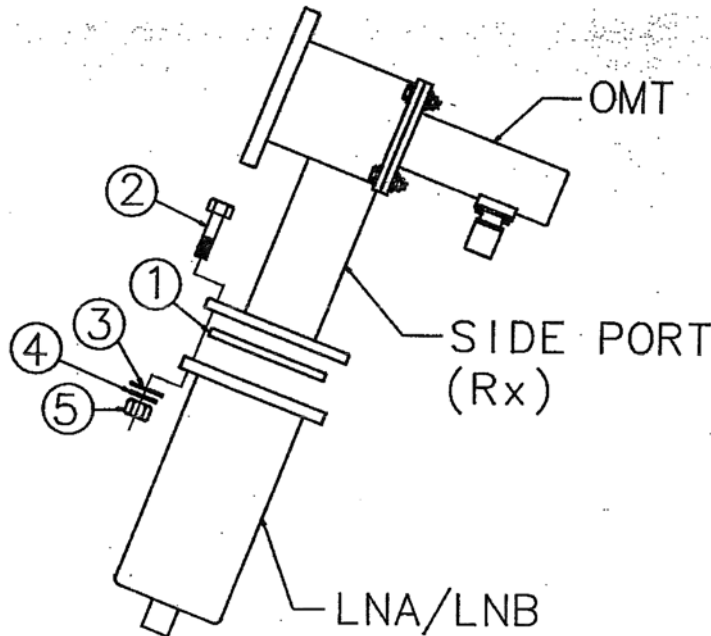

FIGURE 2.2-1