

GENERAL DYNAMICS

C4 Systems

4096-714

Revision A

January 19, 2006

ASSEMBLY MANUAL

2.88" OD Universal Mast Mount

GENERAL DYNAMICS

PRODELIN CORPORATION

1500 Prodelin Drive

Newton NC 28658USA

Phone 828-464-4141

www.gdsatcom.com

2.88" O.D. Universal Mast Mount

A	Revised step #2.2-8.	05/10/06	R.F.
-	ORIGINAL RELEASE	1/19/2006	R.F.
REV.	<u>DESCRIPTION</u>	<u>DATE</u>	<u>APPROVED</u>

TABLE OF CONTENTS

<u>SECTION</u>	<u>TITLE</u>
I	INTRODUCTION
1.0	GENERAL INFORMATION
1.1	SPECIFICATIONS
1.2	UNPACKING & INSPECTION
1.3	FREIGHT DAMAGE
1.4	MATERIAL MISSING OR DAMAGED
1.5	MECHANICAL INSTALLATION TOOLS
II	MOUNT ASSEMBLY
2.0	LOCATION OF TRIPOD ANCHOR BOLTS
2.1	PARTS LIST
2.2	MOUNT ASSEMBLY
III	MAINTENANCE
3.0	MAINTENANCE OVERVIEW
3.1	PERIODIC INSPECTION
3.2	MOUNT STRUCTURE

Universal Mast Mount Installation Instructions

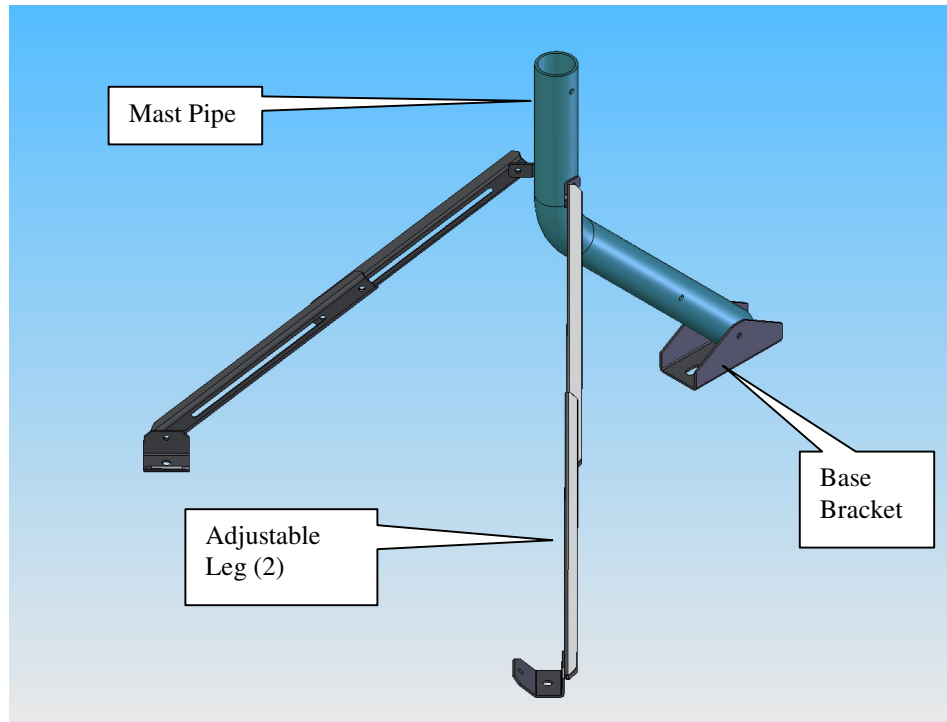

Universal Mast Mount Assembly

SECTION I INTRODUCTION

1.0 GENERAL INFORMATION

This manual describes the assembly and installation of Prodelin's Universal Mast Mount. The Universal Mast Mount is designed to provide a variety of solutions to the problems associated with installing antennas on buildings. The mast can be mounted on flat or sloping roof surfaces, vertical walls, or concrete ground slabs.

1.1 SPECIFICATIONS

The Universal Mast Mount described in this manual is designed primarily to be used with Prodelin Corporation's 1.2m antenna systems requiring a 2.88" o.d. mast pipe. But it may be used with any antenna 1.2m or smaller requiring a 2.88" o.d. mast pipe. When properly installed, the Universal Mast Mount can safely support 1.2m antennas in winds up to 150mi/h.

NOTE: Due to the wide variety of building designs and installation configurations possible, it is beyond the scope of this manual to provide details for connection of the mount to any particular building or other structure. It is

the responsibility of the installer to provide suitable foundations or anchorages for this assembly. Maximum forces at the anchor bolts for both vertical and horizontal mounting configurations of the mount are given in figures 2.0-1 and 2.0-2.

1.2 UNPACKING AND INSPECTION

The system containers should be unpacked and inspected at the earliest date to insure that all material has been received and is in good condition. A complete parts list for each major component is provided in Section 2.1 of this document.

1.3 FREIGHT DAMAGE

Any damage to materials while in transit should be immediately directed to the freight carrier. He will instruct you on matters regarding any freight damage claims.

1.4 MATERIAL - MISSING OR DAMAGED

Any questions regarding missing or damaged materials that is not due to the freight carrier should be directed to Prodelin's Customer Service Department at:

**PRODELIN CORPORATION
1500 Prodelin Drive
Newton NC 28658
(828) 464-4141**

1.5 MECHANICAL INSTALLATION TOOLS

The following tools are suggested for the antenna installation.

- 1 drive ratchet - 3/8"
- 1 socket, - 9/16"
- 1 wrench, combination - 9/16"
- 1 carpenters level or inclinometer

SECTION II MOUNT ASSEMBLY

2.0 LOCATION OF TRIPOD ANCHOR BOLTS

2.0.1 For vertical or horizontal installations the dimensions shown in figures 2.0-1 and 2.0-2 may be used to locate the mounting bolts. Note that the tripod holes are sized for 1/2" anchor bolts (not included).

2.0.2 For sloped roof installations, assemble the tripod according to the instructions in section 2.1, keeping all hardware only snug-tight. Position the tripod in the desired location on the sloped roof. Using a level or inclinometer, plumb the mast to vertical by adjusting the legs. When all pads are flush with the mounting surface and the mast is vertical, mark the location for the anchor bolts. This method allows the installer some leeway in choosing the location for the legs (so that they may be positioned over structural members perhaps).

2.1 PARTS LIST

ITEM	PART #	DESCRIPTION	QUANTITY
1	0250-917	MAST PIPE	1
2	0211-879	MOUNTING BASE BRACKET	1
3	0211-880	LEG MOUNTING BRACKET	2
4	0247-346	ADJUST. LEG – INNER	2
5	0247-347	ADJUST. LEG – OUTER	2
6	0211-1021	MAST MOUNTING BRACKET	2
7	8032-032	3/8-16 x 4.00" BOLT	1
8	8039-008	3/8-16 x 1.00" CARRIAGE BOLT	10
9	8201-042	3/8" FLAT WASHER	12
10	8202-042	3/8" LOCK WASHER	11
11	8102-007	3/8-16 HEX NUT	11

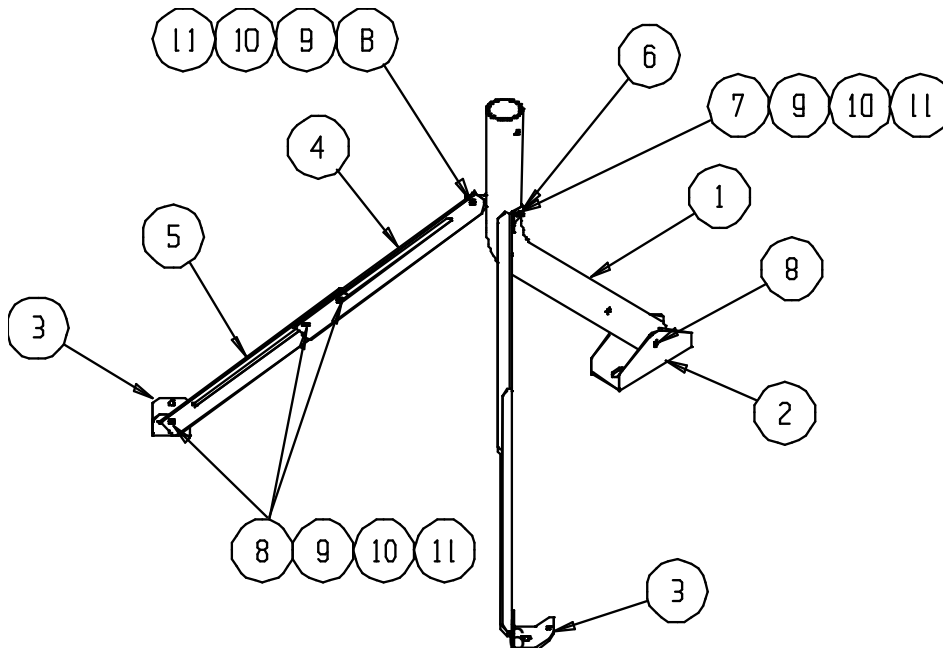

2.2 TRIPOD ASSEMBLY

- 2.2-1 Determine installation site. (vertical surface (wall), horizontal surface (ground), or sloped surface)
- 2.2-2 There are several assembly configurations for the mount. Refer to Figure 2.2-1 to determine the correct assembly configuration for your installation site.
- 2.2-3 Referring to Figure 2.2-1, configuration #1 is used on wall installations and on roofs with slopes up to 15° (from vertical). Configuration #2 is used for ground installations and on roofs with slopes greater than 70° (from vertical). Configuration #3 is used on sloped roofs from 15° to 50° (from vertical). And configuration #4 is used on sloped roofs from 50° through 70° (from vertical). (Note that configurations #3 and #4 are assembled the same and only differ in the orientation of the legs and mast when installed.)
- 2.2-4 Begin assembly by attaching the Mounting Base Bracket (item #2) to the Mast Pipe (item #1). Align the holes in the bracket with the end holes in the mast pipe and insert (2) 3/8" x 1" carriage bolts (item #8) from inside the mast pipe out through the holes in the bracket. Secure with a 3/8" flat washer, lock washer, and hex nut (items #9, 10, 11) on each of the carriage bolts. Snug but do not tighten at this time. **(Note that the bracket should be attached to the correct end of the mast pipe. Attach to the long end for configuration #1 & #2 and to the short end for configuration #3 & #4.)**
- 2.2-5 Attach the (2) Mast Mounting Brackets (item #6) to the mast pipe. Slide a 3/8" x 4" bolt and flat washer through the hole in the short leg of one bracket, through the hole in the mast pipe, and through the hole in the short leg of the other bracket. Secure using a 3/8" flat washer, lock washer, and hex nut (items #9,10,11). Snug but do not tighten at this time.
- 2.2-6 Assemble the legs by placing one Inner Adjustment Leg (item #4) inside one Outer Adjustment Leg (item #5) and securing with (2) 3/8" x 1" carriage bolts, flat washers, lock washers, and hex nuts (items # 8, 9, 10, 11) in the locations shown in Figure 2.2-1. Tighten this hardware snug only, so that the legs may be adjusted for length. Repeat for the second adjustment leg.

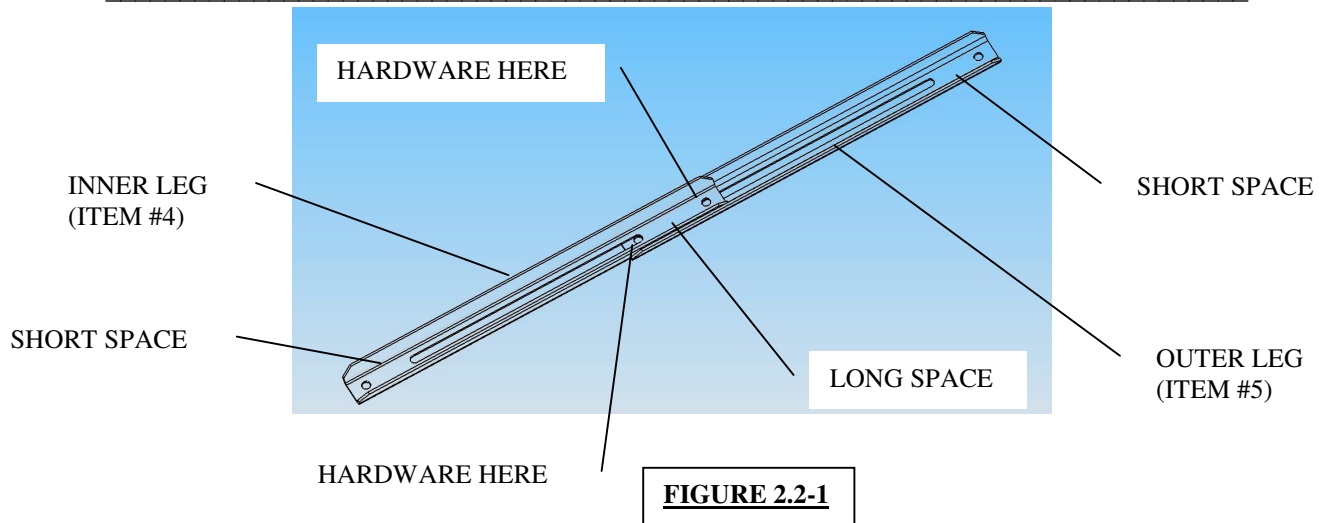

- 2.2-7 Attach one leg assembly to each of the mast mounting brackets on the mast pipe assembly using a 3/8" x 1" carriage bolt, flat washer, lock washer, and hex nut (items #8, 9, 10, 11) for each leg. Snug but do not tighten.
- 2.2-8 Attach one Leg Mounting Bracket (item #3) to the opposite end of each leg assembly using a 3/8" x 1" carriage bolt, flat washer, lock washer, and hex nut (items #8, 9, 10, 11) for each leg. Snug but do not tighten. **Note that the adjustment leg should attach on the 45° leg of the bracket for configuration #4 and on the 90° leg of the bracket for configurations #1, 2, or 3.**
- 2.2-9 Locate the mount assembly at the installation site and secure with the appropriate anchors. For a ground or wall installation, the dimensions shown in Figures 2.0-1 and 2.0-2 may be used to locate the anchors. For sloped roof installations, locate the assembly with the mast roughly plumb and transfer the hole locations to the mounting surface.
- 2.2-10 Using a level against the outside of the mast pipe, adjust the pipe until plumb by allowing the adjustable legs to lengthen or shorten as required.
- 2.1-11 With the mast pipe plumb, tighten all 3/8" hardware securely.

The mount is now ready for installation of the antenna system.

1.2M UNIVERSAL MAST MOUNT
HORIZONTAL MOUNTING INTERFACE AND LOADS

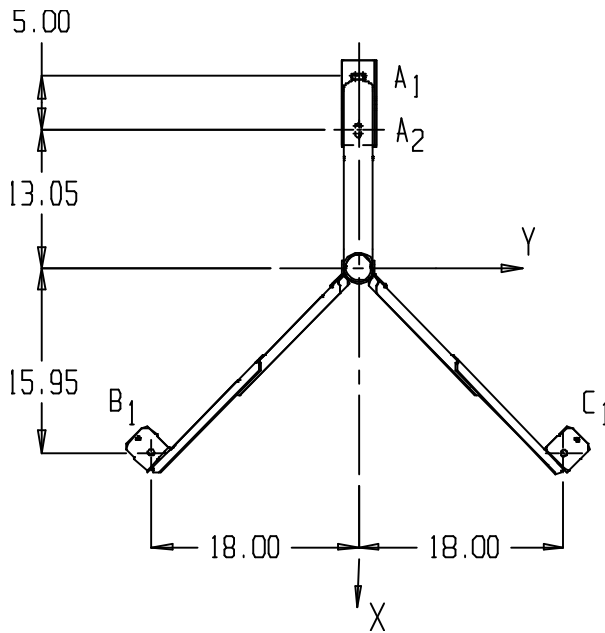

MAXIMUM FORCES IN LBS AT BOLT
LOCATIONS FOR 150 Mi/H WIND
1.2M ANTENNA

	F _x	F _y	F _z
A ₁	749	562	1239
A ₂	749	562	1239
B ₁	375	375	994
C ₁	375	375	994

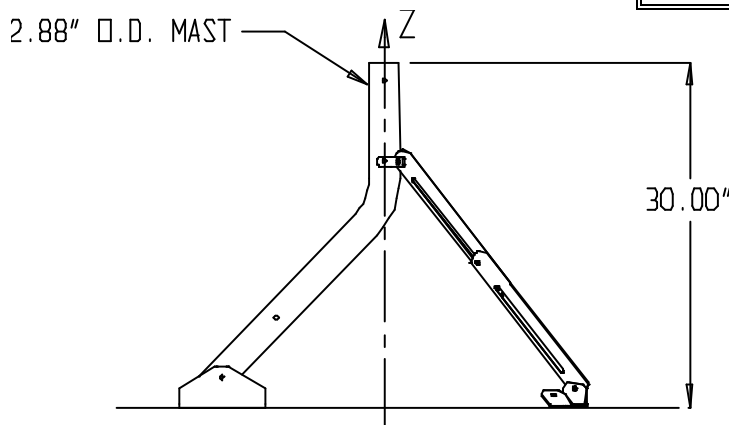
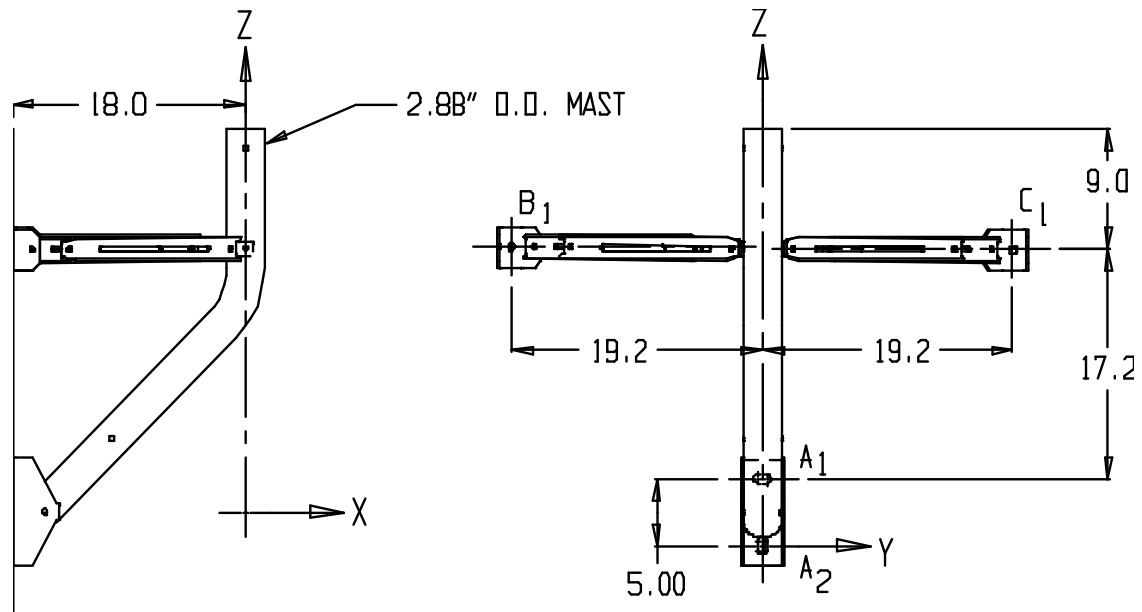

Figure 2.0-1

NOTES:

1. ALL FORCES MAY BE POSITIVE OR NEGATIVE IN DIRECTION.
2. MOUNTING HOLES SIZED FOR 1/2" DIA. ANCHOR BOLTS.

1.2M UNIVERSAL MAST MOUNT
VERTICAL MOUNTING INTERFACE AND LOADS



MAXIMUM FORCES IN LBS AT BOLT LOCATIONS FOR 150 Mi/H WIND

1.2M ANTENNA

	F _x	F _y	F _z
A ₁	331	115	230
A ₃	331	115	230
B ₁	1195	1209	187
C ₁	1195	1209	187

FIGURE 2.0-2

NOTE:

1. ALL FORCES MAY BE POSITIVE OR NEGATIVE IN DIRECTION.
2. MOUNTING HOLES SIZED FOR 1/2" DIA. ANCHOR BOLTS.

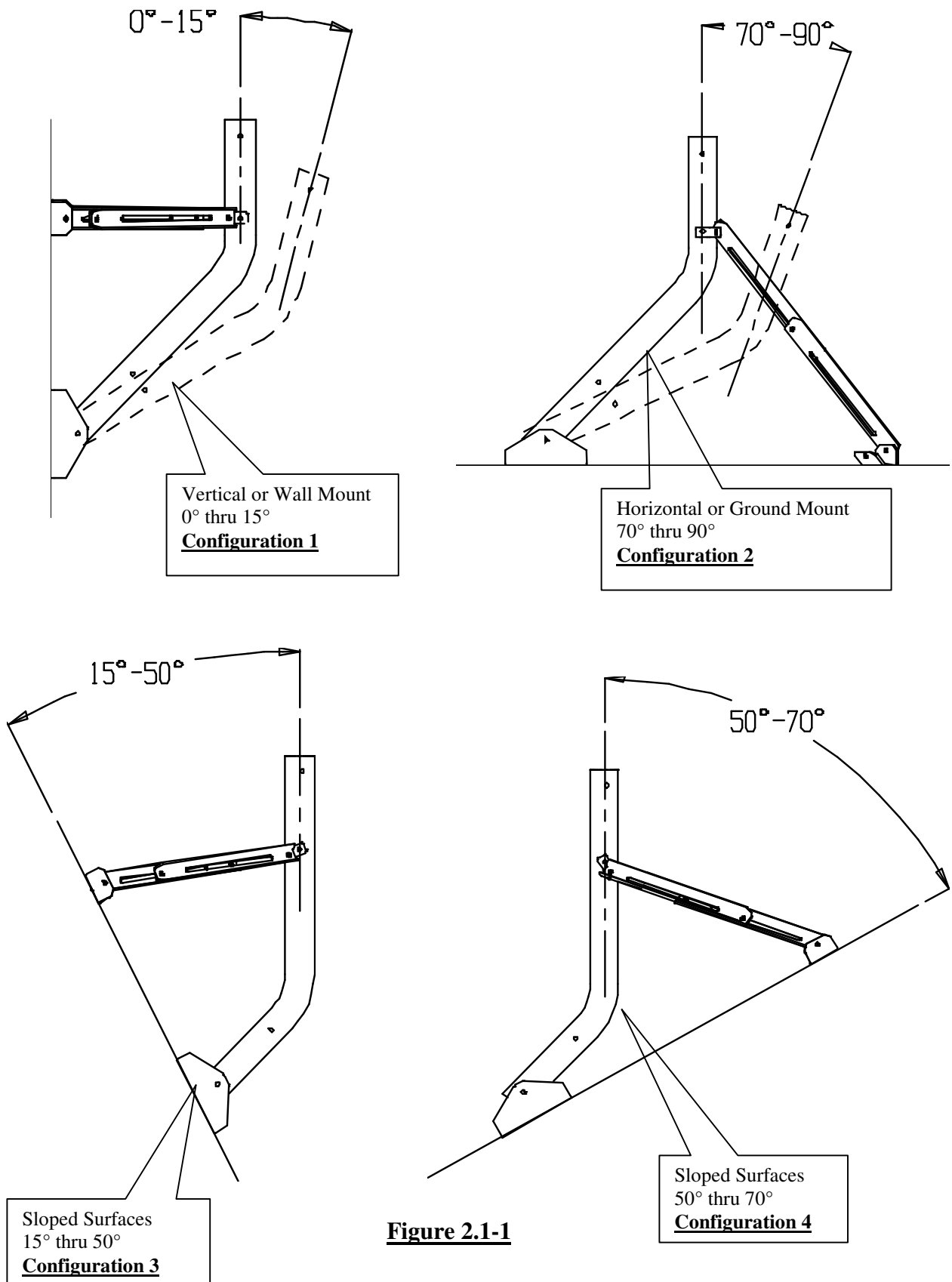

SECTION III MAINTENANCE

3.0 MAINTENANCE OVERVIEW

After installation, the mount requires only periodic inspection. It is anticipated that maintenance, if required, will be minimal and easily handled by a local or in-house maintenance staff. The materials used in the construction of this Universal Mast Mount virtually eliminate any maintenance repairs.

3.1 PERIODIC INSPECTION

It is suggested that a periodic inspection be performed at least every six months.

NOTE: After any severe weather conditions, inspection of the antenna should be performed to determine if foreign objects have caused damage or if survival specifications have been exceeded.

This inspection should include the following:

STEP 1: Check all bolting locations - all bolts should be tight.

STEP 2: Check all structural members - repair or replace if damaged.

STEP 3: Check the foundation anchor bolts - they must be secure and no failure signs in foundation.

STEP 4: Check for corrosion - on the reflector structure and the mount.

3.2 MOUNT STRUCTURE

The mount structure is of steel construction and has a galvanized finish.

If inspection shows any signs of structural failure, the mount members that are damaged should be repaired or replaced.

CORROSION: Any corrosion on steel members may be repaired with a cold, zinc-rich galvanizing paint.