

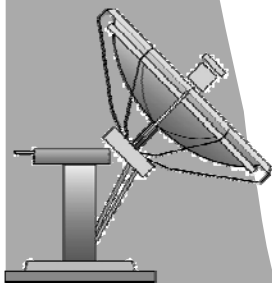

C-Band Transceiver Operating Manual

**Extended-EC
Super Extended-SEC
INSAT-XC
Russian-RC
PALAPA-PC
LMC**

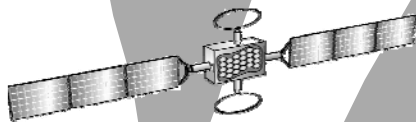

ANASAT[®]-C Series



Rev 10

ANASAT[®]-C Quick Start Guide

There is a lot more inside the manual, but here are the most important steps:

1. Mount the transceiver and the LNC on the antenna.
2. Connect the cables as shown in the drawing (See page 2-3 of Operations Manual).
3. Connect a terminal to a serial port, configured to 1200bps, 8 data bits, no parity, 1 stop bit, CR/LF Off. Connection diagrams are in Appendix C.
4. Install a proper power connector on the (included) power cable. Plug the cable into 110 or 240VAC, 50/60Hz. Verify the green LED on the transceiver is blinking, indicating normal internal operation. The red LED is usually OFF. If illuminated, it indicates an alarm condition requiring attention. Refer to the ALARM command for details (Appendix A).
5. Using the terminal, configure the transceiver to the proper frequency:
 RXFREQ nnnn (nnnn in MHz —see Appendix D for channel)
 TXFREQ nnnn (nnnn in MHz —see Appendix D for channel)
6. Configure receive gain and transmit output power:

RXGAIN	nnn	nnn ranges from	85 to 100	
TXGAIN	nn	nn ranges from:	10 to 36 [0C]	44 to 70 [2C]
			48 to 74 [5C]	51 to 77 [10C]
			54 to 80 [20C]	57 to 83 [30C, 40C]
			58 to 84 [50C, 60C]	60 to 86 [70C, 80C]
			61 to 87 [100C]	62 to 88 [125C]
			63 to 89 [150C]	64 to 90 [180C]
				64 to 90 [200C]
7. Enable the Transmitter:
 TX ON (TX OFF takes the transmitter OFF air)

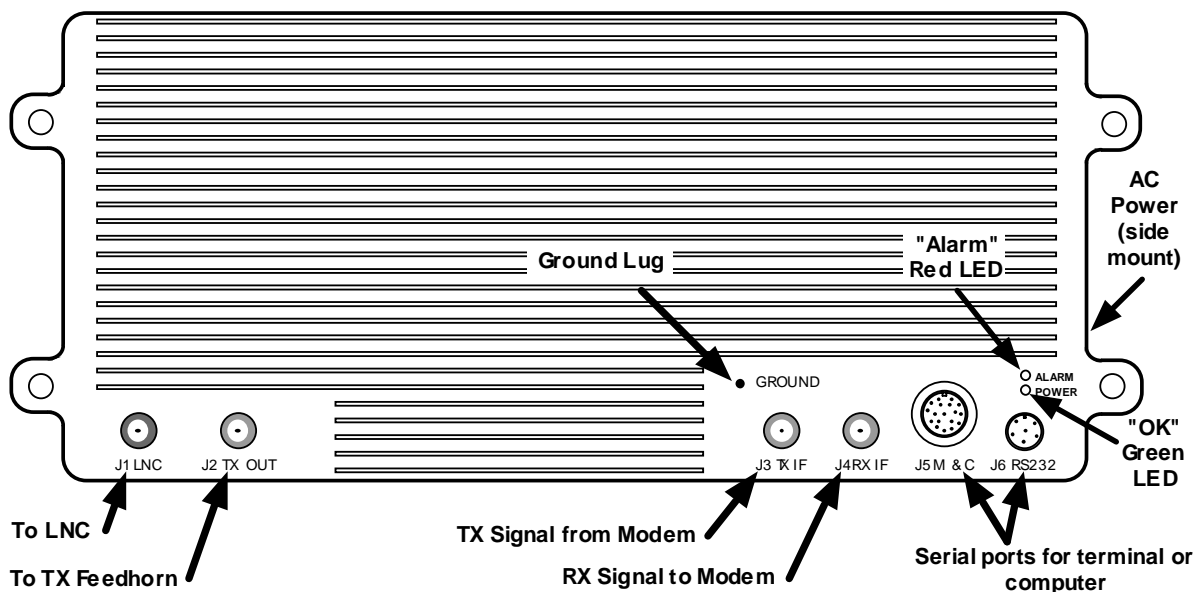

That's really all you must do! Good luck with your new ANASAT[®]-C Transceiver!



ANASAT[®]-C Series

C-Band Transceiver Operating Manual

Extended—EC
Super Extended—SEC
Russian —RC
PALAPA—PC
INSAT—XC
LMC

You have just received an AnaSat[®]-C Transceiver, a *cost-effective* product with no compromise on *quality* and *reliability*. This product should provide tireless performance in any reasonable operating environment.

We, at ANACOM, have taken great care to provide a convenient, easy-to-use product in a single package. Our powerful Monitor and Control enables you to set transmit and receive frequencies and gains and monitor numerous major and minor operational parameters using a “dumb terminal” interface. There’s no need to worry about available voltages; the internal universal power supply can automatically accommodate virtually all AC voltage possibilities.

Should a situation arise beyond the operator’s control, just give us a telephone call. Many situations can be diagnosed and solved by ANACOM’s trained customer-service personnel over the phone.

If you have any questions, require technical assistance or training please call ANACOM directly at (408) 519-2062 or FAX to us at (408) 519-2063. You can also send e-mail to techsupport@anacominc.com and one of our engineers will contact you.

ANACOM, INC.

**1996 Lundy Ave.
San Jose, CA 95131
Tel: (408) 519-2062
Fax: (408) 51-2063**

© 2009 AnaCom, Inc. All rights reserved. The information furnished by AnaCom, Incorporated, in this publication is believed to be accurate and reliable. However, no responsibility is assumed by AnaCom for its use, nor any infringements of patents or other rights of third parties resulting from its use. No license is granted by implication or otherwise under any patent or patent right of AnaCom, Inc. AnaCom reserves the right to change circuitry and specifications at any time without prior notice.

The following terms are trademarks of their respective holders:

AnaSat, AnaCom, Inc.

Polyswitch

Teflon

Duroid

VT52, VT100 Digital Equipment Corp.

INTELSAT



Operating Manual

for the

ANASAT[®]-C-Series

C-Band Transceiver

Table of Contents

<u>Subject</u>	<u>Page</u>
Section 1. Product Introduction and Specifications	1-1
Typical Operating Parameters	1-2
 Section 2. Installation	
Unpacking	2-1
Packing List	2-1
Safety Precautions	2-2
Site Considerations	2-2
Transceiver Mounting Considerations	2-3
Grounding	2-3
Cable and Waveguide Connections	2-6
Water Resistance Wrap	2-7
 Section 3. Operation	
Preliminary Steps	3-1
M & C Operation	3-2
Gain Adjustments	3-4
Quick Start Guide	3-6

<u>Subject</u>	<u>Page</u>
Section 4. Theory of Operation	
Signal Path	4-1
Control & Power Systems	4-1
Low Noise Converter	4-1
Converter Module	4-3
Power Amplifier	4-5
Monitor & Control Unit	4-6
Frequency Reference	4-9
Power Supply	4-9
Section 5. Maintenance	5-1
LNC Replacement	5-2
Limited Warranty	5-3
Appendices	
Appendix A. M & C Command Set	A-1
Appendix B. Alarm List	B-1
Appendix C. Serial Port Wiring	C-1
Appendix D. C-Band Satellite Channel Frequencies	
ANASAT [®] -EC Satellite Channels	D-1
ANASAT [®] -SEC Satellite Channels	D-4
ANASAT [®] -XC Satellite Channels	D-7
ANASAT [®] -PC Satellite Channels	D-10
ANASAT [®] -RC Satellite Channels	D-12
ANASAT [®] -LMC Satellite Channels	D-15
Appendix E Converting dBm to Watts and Watts to dBm	E-1
Appendix F Transceivers Weights & Dimensions	F-1

Section 1. Introduction



Figure 1-1 The ANASAT®-C VSAT transceiver (5W version shown)

The ANASAT®-C VSAT series C-Band transceivers are designed for continuous outdoor duty in all types of environments. Ideally suited for SCPC, MCPC, and DAMA applications, the ANASAT®-C series transceivers transmit in the 6 GHz frequency range and receive in the 4 GHz range.

The ANASAT®-C VSAT transceivers integrate all necessary functions, including the solid-state power amplifier (PA), into a small, highly integrated outdoor package. The only cabling required to the indoor plant are the IF and AC power cables. The LNC connects to the transceiver with a single coaxial cable.

Designed to interface with any 70 MHz modem, the ANASAT®-C VSAT transceiver may be used in a wide variety of communication networks. The earth stations may be configured in Star, Mesh, or Ring networks and with the optional Station Management System (SMS) tied to a PC, you can moni-



Figure 1-2. The ANASAT®80C, showing cooling fan

tor and control all local transceivers and other network-compatible equipment.

The ANASAT®-C transceiver upconverts the modulator's 70 MHz IF output to an RF signal in the 6 GHz range for transmission, and downconverts the 4 GHz received RF signal to a 70 MHz IF signal for use by the demodulator.

The PA uses Internally-Matched Field-Effect Transistors (IMFET) to achieve highly linear power and gain with minimal intermodulation distortion (IMD) products.

High Electron Mobility Transistors (HEMT) and Gallium-Arsenide Field-Effect Transistors (GaAs FET) enable the Low-Noise Down-Converter (LNC) to achieve a noise figure better than 35 °K.

The transmit (TX) and receive (RX) synthesizers are locked to an oven controlled, high-stability crystal oscillator (OCXO) and can provide 1 MHz frequency selection step sizes over the entire bandwidth. TX and RX frequency selection is completely independent for extra flexibility.

In this manual, all frequency ranges reflect the Standard "C" model of the ANASAT®-C transceiver except as noted.



Figure 1-3. The ANASAT®100C, Higher Power

Typical Operating Parameters

RF ELECTRICAL SPECIFICATIONS

A. FREQUENCIES

		<u>Model</u>	<u>(1 MHz step size)</u>
(1)	Transmit RF (N-Connector on 0, 2, 5,10, 20 and 40W) (CPR-137G Waveguide on 30,50,60,70... ...80, 100, 150 and 200W)	EC	5850 to 6425 MHz
		SEC	5850 to 6725 MHz
		XC	*6725 to 7025 MHz
			<i>*(500 kHz step size)</i>
		RC	5975 to 6475 MHz
		PC	6425 to 6725 MHz
	LMC	5725 to 6475 MHz	
(2)	Receive RF (CPR-229G Flange on LNC)	EC	3625 to 4200 MHz
		SEC	3400 to 4200 MHz
		XC	*4500 to 4800 MHz
			<i>*(500 kHz step size)</i>
		RC	3650 to 4150 MHz
		PC	3400 to 3640 MHz
	LMC	3375 to 3950 MHz	
(3)	Transmit IF (N-connector) Optional	all	52 to 88MHz (70 ± 18 MHz) 104 to 176 MHz (140 ± 36 MHz)
(4)	Receive IF (N-connector) Optional	all	52 to 88MHz (70 ± 18 MHz) 104 to 176 MHz (140 ± 36 MHz)

B. RF POWER LEVELS

(1)	Receiver Output Intermod. By Product		-35 dBc max., measured with two carriers @ -80 dBm, 30 kHz apart
(2)	Transceiver Input		-40 to -20 dBm; +20 dBm max.
(3)	Transceiver Output (a) + 25°C at Transmit RF Connector		

	<u>1dB COMP. PT</u>		<u>1dB COMP. PT</u>
(0 dBm)	0 dBm min.	(80 watt)	49 dBm min.
(2 watt)	33 dBm min.	(100 watt)	50 dBm min.
(5 watt)	37 dBm min.	(125 watt)	51 dBm min.
(10 watt)	40 dBm min.	(150 watt)	51.8 dBm min.
(20 watt)	43 dBm min.	(180 watt)	52.6 dBm min.
(30 watt)	44.8 dBm min.	(200 watt)	53 dBm min.
(40 watt)	46 dBm min.	(300 watt)	54.8 dBm min.
(50 watt)	47 dBm min.	(350 watt)	55.4 dBm min.
(60 watt)	47.8 dBm min	(400 watt)	56 dBm min.
(70 watt)	48.5 dBm min		

(b) Gain Variation, -40°C to +50°C @ Transmit RF and under all conditions

± 1.5 dB

(c) Intermodulation By-Products (IP) (measured at a power
output of 9dB composite below the P-1dB spec)

-33 dBc max.

RF ELECTRICAL SPECIFICATIONS, (con't.)
C. RECEIVER GAIN

(1)	Overall Gain (at +25°C)	85 to 100 dB
(2)	Gain Variation under all conditions	± 1.5 dB

D. RECEIVER NOISE FIGURE (standard)
 (optional)
 (optional)

0.9 dB (65°K) max.
0.63 dB (45°K) max.
0.5 dB (35°K) max.

E. INSTANTANEOUS BANDWIDTH

(1) Receiver RF to IF	± 18 MHz for 70 MHz IF
Optional	± 36 MHz for 140 MHz IF
(2) Transmitter IF to RF	± 18 MHz for 70 MHz IF
Optional	± 36 MHz for 140 MHz IF

F. IMPEDANCE

(1) Receiver Output	50Ω; (75Ω optional)
(2) Transmitter Input	50Ω; (75Ω optional)

G. SYNTHESIZERS

(1) Tuning Step Size	1 MHz, except 0.5 MHz XC (M & C controlled)
(2) Phase Noise (offset from carrier)	-60 dBc / Hz @ 100 Hz -70 dBc / Hz @ 1 kHz -80 dBc / Hz @ 10 kHz -90 dBc / Hz @ 100 kHz -100 dBc / Hz @ 1 MHz

H. FREQUENCY REFERENCE

Stability over temperature	
-40°C to +50°C	1 x 10 ⁻⁸
-50°C for RC Units	
Aging	1 x 10 ⁻⁹ / day

RF / IF CONNECTOR DESIGNATIONS

A.	Receive Input on LNC	CPR-229G Flange
B.	Transceiver LNC input	N-Type-Female
C.	LNC Output	N-Type-Female
D.	Receive IF	N-Type-Female
E.	Transmit IF	N-Type-Female
F.	Transmit Output	N-Type Female

(CPR-137 Flange optional on 10, 20, and 40W versions)
 (CPR-137 required on 50W and above versions)

INTERFACE ELECTRICAL SPECIFICATIONS

	(1)	Power Requirement			100 to 240 VAC 50/60 Hz
	(2)	Typical Power Consumption			
0 dBm		41 VA	50 watt	394 VA	150 watt 1179 VA
2 watt		73 VA	60 watt	398 VA	180 watt 1539 VA
5 watt		83 VA	70 watt	570 VA	200 watt 1539 VA
10 watt		125 VA	80 watt	572 VA	300 watt 2832 VA
20 watt		229 VA	100 watt	762 VA	350 watt 2832 VA
30 watt		280 VA	125 watt	1179 VA	400 watt 2832 VA
40 watt		390 VA			
	(3)	Prime Power Recommendation			
0 dBm		100 VA	50 watt	880 VA	150 watt 2400 VA
2 watt		150 VA	60 watt	890 VA	180 watt 3100 VA
5 watt		220 VA	70 watt	1200 VA	200 watt 3100 VA
10 watt		340 VA	80 watt	1200 VA	300 watt 6200 VA
20 watt		600 VA	100 watt	1600 VA	350 watt 6200 VA
30 watt		735 VA	125 watt	2400 VA	400 watt 6200 VA
40 watt		870 VA			

INTERFACE CONNECTION DESIGNATIONS

(1)	Ports (Configurable)	2 each RS-232 or 1 RS-232 & 1 RS-485
(2)	Protocol	RS-232 port supports any “dumb” terminal or ASCII interface RS-485 port supports addressed, packetized data per ANACOM Supervisor™ software specifications
(3)	Alarm Relays	Form-C for Major and Minor alarms; isolated. Independent TX and RX relay alarms in Protection Mode
(4)	Visual Indicators	Flashing GREEN LED indicates active power Flashing RED LED indicates summary alarm

MECHANICAL SPECIFICATIONS
A. WEIGHT

	(1)	<u>Transceiver</u>			
0 dBm		23 lbs (10.5kg)	50 watt	57 lbs (25.9kg)	150 watt 102 lbs (46.3 kg)
2 watt		27 lbs (12.3kg)	60 watt	57 lbs (25.9kg)	180 watt 136 lbs (62 kg)
5 watt		29 lbs (13.2kg)	70 watt	57 lbs (25.9kg)	200 watt 136 lbs (62 kg)
10 watt		32 lbs (14.5kg)	80 watt	62 lbs (28.1kg)	300 watt 280 lbs (127 kg)
20 watt		39 lbs (17.7kg)	100 watt	75 lbs (34.1kg)	350 watt 280 lbs (127 kg)
30 watt		57 lbs (25.9kg)	125 watt	102 lbs (46.3kg)	400 watt 280 lbs (127 kg)
40 watt		45 lbs (20.5kg)			

MECHANICAL SPECIFICATIONS (con't.)

(2) LNC 0.70 lbs (0.32 kg)

B. SIZE

(1) Transceiver

0 dBm, 2 watt, 5 watt	21.6" x 9.0" x 7.0" (549 x 229 x 178 mm)
10 watt	21.6" x 9.0" x 11.6" (549 x 229 x 295 mm)
20 watt	21.6" x 9.0" x 13.5" (549 x 229 x 343 mm)
30 watt, 50 watt, 60 watt, 70 watt	21.6" x 9.0" x 15.0" (549 x 229 x 381 mm)
40 watt	21.6" x 9.0" x 14.0" (549 x 229 x 356 mm)
80 watt	21.6" x 9.0" x 16.0" (549 x 229 x 407 mm)
100 watt	21.6" x 13.0" x 14.0" (549 x 330 x 356 mm)
125 watt, 150 watt, 180 watt, 200 watt	38.0" x 13.0" x 12.5" (965 x 330 x 318 mm)
300 watt, 350 watt, 400 watt	38.0" x 25.5" x 12.36" (965 x 648 x 314 mm)

(2) LNC 3.7" x 2.8" x 3.9"
(91x 71 x 99 mm)

C. SURFACE FINISH

Painted Surface
 (a) Color (per FED-STD-595A, Spec. # 25630) Light Gray
 (b) Final Coating: Powder
 Unpainted Surfaces: Chem. Film per MIL-C-5541, Class 3

ENVIRONMENTAL SPECIFICATIONS
A. AMBIENT TEMPERATURE CONDITIONS

(1) Operating -40 to +50°C
 (2) Storage -60 to +75°C

B. ALTITUDE 10,000 ft ASL max. (3,000m)

C. RAIN 20" / hour (508mm/hr)

D. WIND 150 MPH (250km/hr)

E. VIBRATION

(1) Operating 1.0 G random
 (2) Survival 2.5 G maximum random

F. SHOCK

(1) Operating 10 G
 (2) Survival 40 G max.

NOTE: Operating parameters subject to change without notice.

Section 2. Installation

The ANASAT[®]-C transceiver consists of the transceiver, the Low Noise Converter (LNC), and the LNC interconnection cable.

This chapter contains the general requirements for installing the transceiver and LNC on the antenna and making the cable and waveguide connections. Specific mounting methods may vary considerably depending upon particular antenna and site characteristics. Refer to the antenna manufacturer's instructions for more detailed instructions.

ANASAT[®]-C transceivers are designed for installation and setup without removing the cover. The transceiver may be completely initialized for normal operation using an ASCII terminal or a local computer.



Removal of any cover may jeopardize the weather seal which may cause problems later.

Unpacking

Check to make sure that the transceiver has not suffered any damage in shipment. Compare contents of the crate to ensure items received match those listed on the packing slip. Retain all shipping containers for future use.

Tools and Test Equipment

Have on-hand a standard electrician's tool kit and any tools listed in your antenna installation instructions.

Unit		Part Number	Quantity
• Transceiver	—		1
• LNC	for EC, SEC, RC, LMC versions	30570	1
	for XC (INSAT)	30680	1
	for PC (PALAPA)	30816	1
• LNC Screws	1/4-20 X 1" HEX HD.	11837016	10
	1/4-20 X 1 1/2" HEX HD.	11838001	10
	Washer, 1/4" Split Lock	11839001	10
	Washer, 1/4" Flat	11840	10
	Gasket, WR229 - Half	10933	1
	Gasket, WR229 - Full	10934	1
	Gasket, WR137, Half, For Waveguide Output	10935	1
• 10 ft. (3m) LNC to Transceiver Cable with male N-connectors (longer cables also available)		30641010	1
• Power Cable with 4-pin circular connector (one end)		31185015	1
• Cable-End Connectors:	6-pin weathertight circular	10614006	1
	18-pin weathertight circular	10616018	1
• ANACOM Supervisor [™] software CD		30673	1
• Mastic Tape, 30" x 3/4"		10932	1
• Operating Manual		30723	1
• Quick Start Guide			1
• M&C Cable, DB9 to 6 pin circular		30720010	1
Optional Accessories:			
• Andrew 1/4" Helix [™] Low Loss Cable, 3 ft. (0.9m)		11706	
• T/R Filter	for EC, SEC, RC, LMC versions	10917	
	for XC (INSAT)	10937	
	for PC (PALAPA)	10972	
• Transceiver Mounting Kit		12104	

Table 2-1. ANASAT[®]-C Packing List

Safety Precautions

General



Observe normal safety precautions when operating this equipment.

Ensure the ANASAT®-C transceiver and LNC are properly grounded. Do not rely on coaxial cable shields for the ground connection.

If the cover is removed from any ANACOM product, ensure that all:

- gaskets are intact and free of damage prior to reinstallation
- mounting screws are properly installed

Ensure all connectors are properly water-proofed.

Power Supply

Confirm that AC Power is disconnected before removing the transceiver or LNC cover.

Transceiver

Take adequate precautions to ensure the ANASAT®-C transceiver does not transmit a signal until it has been properly connected and set up for authorized frequencies and power levels. The transmitter is normally shipped from the factory with TX ON !



Transmitter RF output power levels are adequate to cause blindness or other serious injury to body tissues. Use caution when working around the transceiver or antenna when the transmitter is active.

Power Amplifier

Be sure the transceiver TX OUT port is properly terminated prior to operation. Ensure all the correct waveguide gaskets are used to prevent water damage.

TO ENSURE PROTECTION OF PERSONNEL AND EQUIPMENT, USE CARE DURING ANTENNA INSTALLATION AND WHENEVER WORKING ON OR AROUND THE SYSTEM.

LNC

Be sure the LNC unit is properly terminated prior to operation. Ensure all the correct waveguide gaskets are used to prevent water damage.

Site Considerations

Peculiar installation requirements of any particular site is the responsibility of the system operator. ANACOM can engineer an optional installation mounting kit, customized for your site and hardware. Contact ANACOM for details.

Antenna

The transceiver must be attached to some form of mounting structure which is usually the antenna feed boom or the antenna bracket structure. Specific mounting procedures will depend on the antenna used. The transceiver and LNC are designed to be mounted on most antennas. Locate and install the antenna according to the antenna manufacturer's instructions. Choose an area that is free of extraneous interference from motors and electronic equipment and has a clear line-of-sight from the antenna to the satellite.

Lightning arrestors should be used at the site to protect personnel and equipment. Size 3/0 or 4/0 stranded copper wire should be used to bond the transceiver to the antenna frame and to the lightning protection ground rod.

Power Requirements

The ANASAT®-C transceiver requires a power source which supplies 110 VAC or 220 VAC at 50 or 60 Hz, through a circuit breaker. Specific circuit breaker size will depend on which transceiver is being used. To assure uninterrupted service, some method of backup AC power is recommended. Installing surge arrestors and AC power line filters will reduce voltage surges from the AC power input. .

NOTE: AC TRANSIENTS AND SURGES MAY CAUSE DATA TRANSMISSION ERRORS AND LOSS OF SYNCHRONIZATION IN THE TRANSCEIVER SYNTHESIZERS AND/OR THE EXTERNAL MODEM EQUIPMENT.

Transceiver Mounting Considerations

The ANASAT®-C transceiver must be mounted such that:

1. Sufficient support is afforded the transceiver to minimize the effects of antenna sway in strong winds.
2. Air movement is possible across the heat sink fins. Ideally, the fins should be aligned vertically, but this is not required.

NOTE: The length (and associated RF losses) of the interconnecting cables must be considered when determining the location of the transceiver and LNC.

Transceiver Mounting

The ANASAT®-C transceiver is designed for mounting in any position. For optimal heat sink action, the heat sink fins should be vertical, or as nearly vertical as is practical. Figure 2-1 shows a common installation example where the transceiver is mounted on the antenna feed support arm.

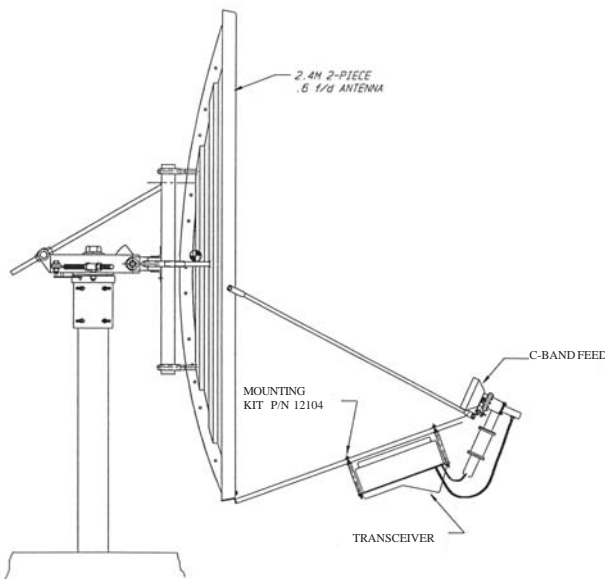

Figure 2-1. Typical transceiver mounting.

When mounting the transceiver, allow enough room to adjust the antenna's azimuth and elevation. Throughout installation and during any polarization, azimuth, or elevation adjustment, ensure the power cables, IF cables, and any waveguide parts are not crimped or pinched.

Figures 2-1a and 2-1b in next pages shows the transceiver mounting for single thread.

Grounding

Electrical bonding (grounding) of the transceiver is required to prevent possible damage from lightning or other induced electrical surges.

The transceiver is provided with both an M3, and a #6 grounding point. It is recommended that heavy gauge copper wire or copper braid be used to bond this unit to the earth ground (grounding rod) using the most direct (shortest) route possible.

LNC/TR Filter Mounting

The LNC is shown in Figure 2-2. Normally the LNC is directly bolted to the antenna RX feed. In some situations, additional transmit-to-receive isolation may be required to achieve true low-noise receive operation. In that case, the optional TR filter (Figure 4-3) should be bolted between the LNC and the antenna receive port. An appropriate waveguide gasket must be included at both ends of the TR filter. Connect one end of the coaxial cable with male N-connectors (included) to the LNC. Refer to the note at the end of this section regarding watertight connections. Route the 10-foot cable to the transceiver and connect to the LNC N-connector. Longer or shorter cable lengths may be used; contact ANACOM for details.

Caution: Never touch the ground-plane antenna pin found inside the wave-guide flange of the LNC. The front-end preamp is susceptible to static discharge.

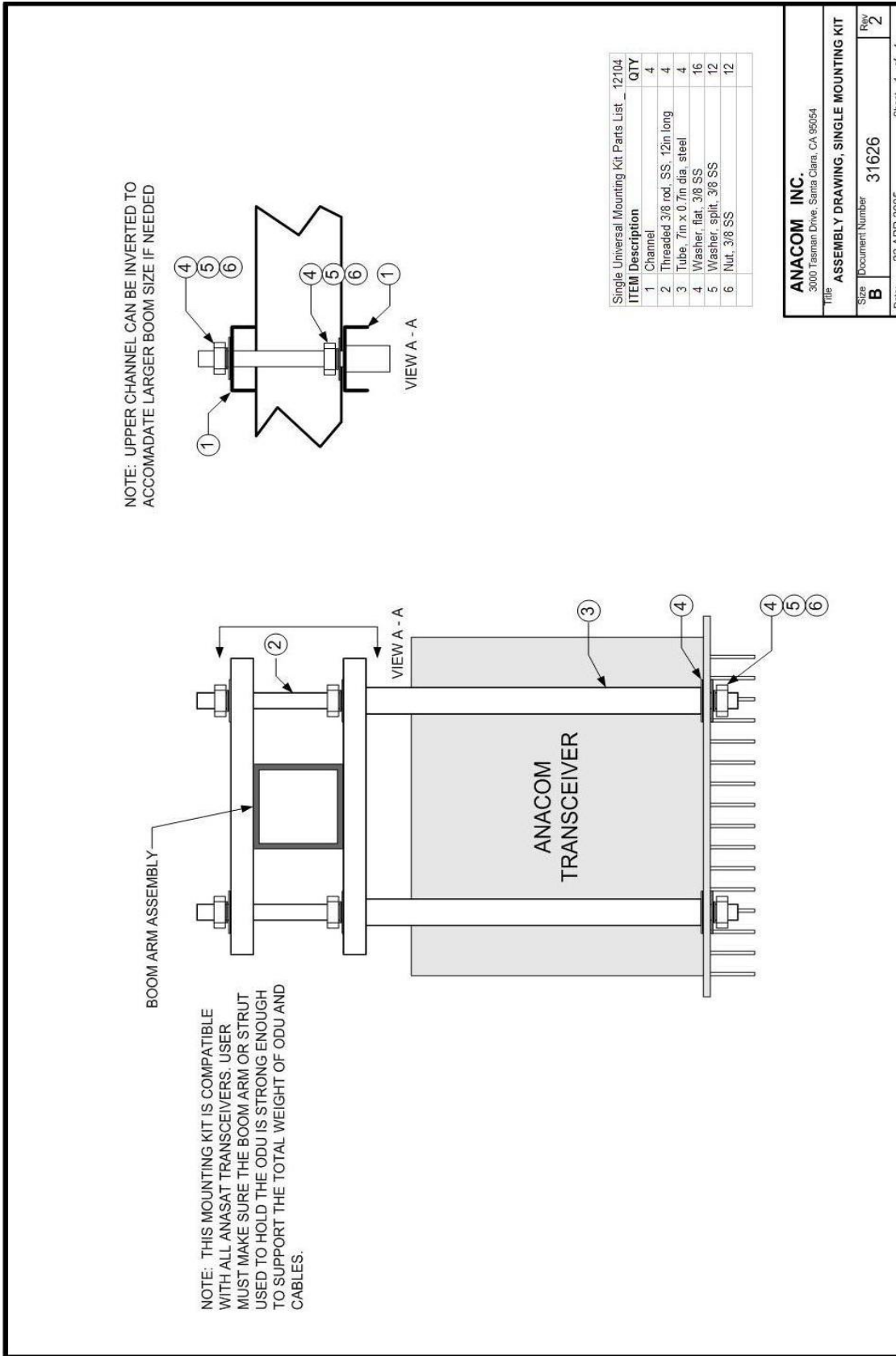
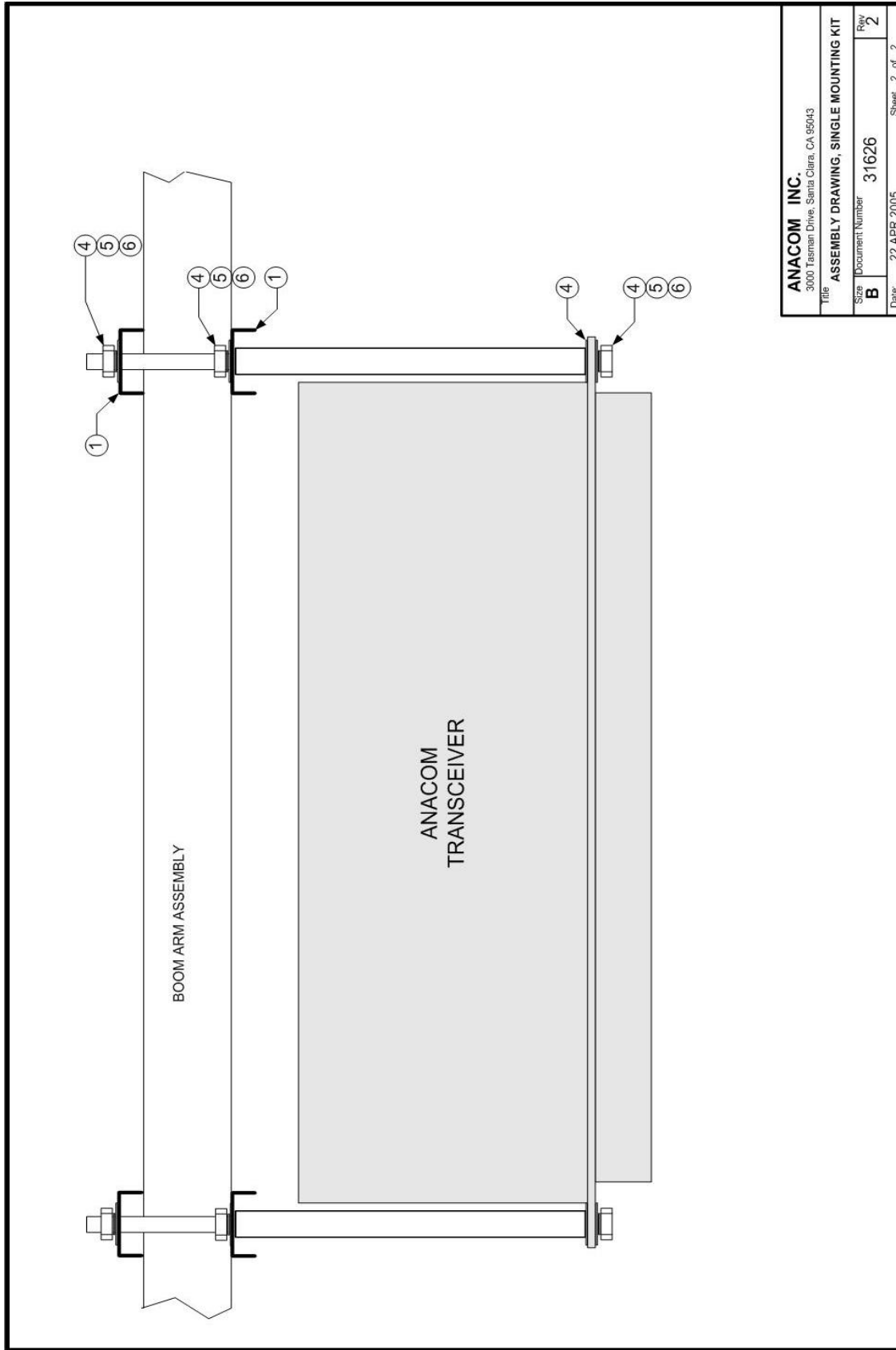

Figure 2-1a Transceiver Mounting for Single Thread



ANACOM INC.	
3000 Tasman Drive, Santa Clara, CA 95043	
Title: ASSEMBLY DRAWING, SINGLE MOUNTING KIT	
Size: B	Document Number: 31626
Rev: 2	Date: 22 APR 2005
Sheet: 2 of 2	

Figure 2-1b Transceiver Mounting for Single Thread



Figure 2-2. LNC assembly.

Cable and Waveguide Connections

Cabling Requirements

Local regulations may require that cables in occupied buildings be installed in steel conduit. Local government agencies may waive this requirement for the use of Plenum cables, which are standard cables entirely encased in solid Teflon. Check the codes in your area.

NOTE: EQUIPMENT OUTAGES DUE TO FAULTY CABLE MATERIALS OR INSTALLATION ARE NOT COVERED BY YOUR WARRANTY.

Figure 2-3 provides the cabling diagram for the ANASAT[®]-C transceiver.

1. Transmitter Feed

Connect a section of low loss cable with a type N connector between the OMT transmit port and the transceiver's transmit output, TX OUT. Ensure the connections are weather-tight.

For transceivers with the CPR-137 flange option, connect a section of flexible CPR-137G waveguide between the antenna OMT transmit port and the transceiver's transmit output, TX OUT. (Waveguide should be attached to the antenna feed per manufacturer's instructions). Ensure a gasket is fitted at each flange.

2. 70MHz Modem

Attach a coaxial cable with male N-connectors between the transceiver's TX IF and the modulator IF OUTPUT. Make sure that the connections are weather-tight.

Attach a coaxial cable with male N-connectors between the transceiver's RX IF and the demodulator IF INPUT. Make sure that the connections are weather-tight.

3. AC Power

Attach the AC input cable to the 4-pin connector on the transceiver. Run the AC cable to the power source *but do not attach yet*. The supplied power cable has a weather-tight circular connector attached to one end. The other end is terminated with flying leads. Attach the proper AC power connector for your location to the end of this cable.

Color code:

Brown.....AC Hot power lead
Blue.....AC Neutral power lead
Green/Yellow.....Ground

4. LNC

Attach the RF cable between the LNC connector and the transceiver LNC input connector. If a longer cable is required, insure that the replacement cable is designed for low loss at microwave frequencies. Maximum loss of the LNC cable must be 5 dB or less at 5 GHz!

5. Terminal Connections

A data terminal or a computer with terminal software connects to the ANASAT[®]-C via either RS-232 or RS-485 serial ports. Appendix C shows the pinout of the serial outputs. Both 6-pin and 18-pin weather-tight circular connectors are included. An optional serial computer cable is available from ANACOM.

Final Check

Recheck all bolts and cabling. Refer to Figure 2-3 to verify cable connections.

After all other connections have been made, connect the AC power cord to an active outlet.

Water Resistance Wrap

The application of moisture-resistant wrap (*mastic tape*) to all connectors is recommended to prevent water entry and resultant water damage. See Figure 2-3. Apply the mastic tape as follows:

1. Ensure that all connectors are tight.
2. Pre-cut the mastic tape to the desired size and remove the protective wax liner from the tape.
3. Center the tape on the connector to be sealed and wrap the tape tightly around the connector. Squeeze the tape tightly and ensure that both ends of the tape have formed around the connector and the cable.
4. Apply the mastic tape to all connectors that may be exposed to moisture.

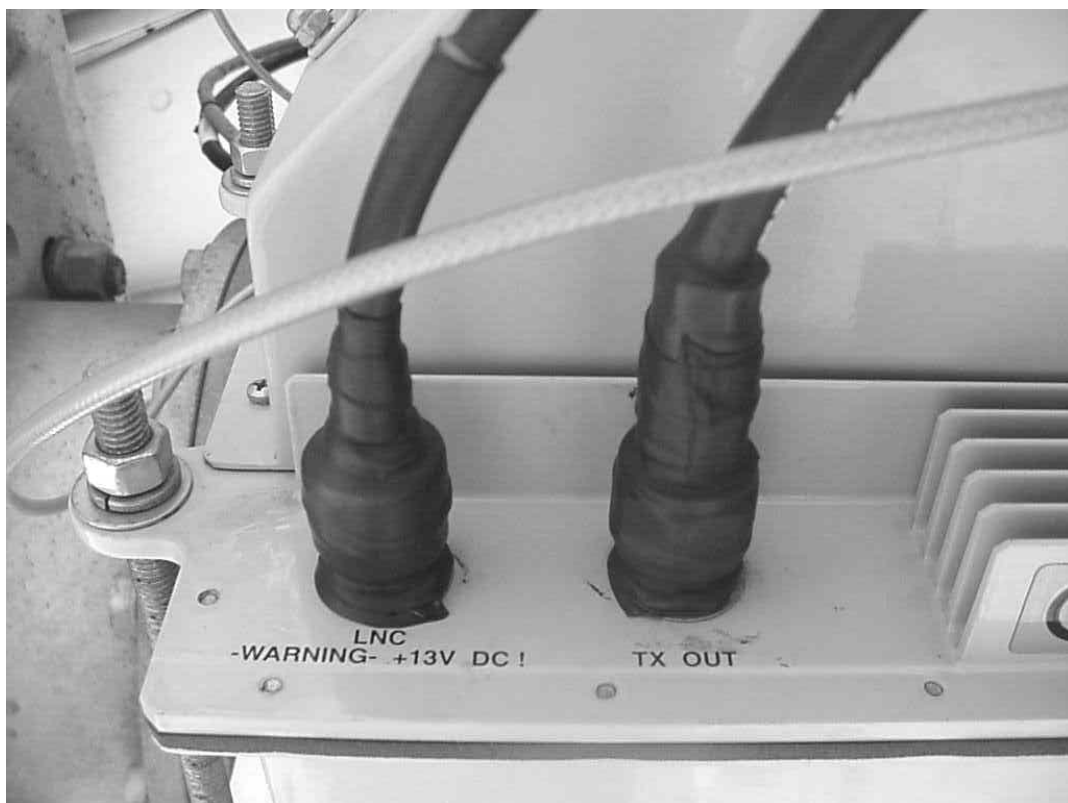

Figure 2-3. Mastic Tape application

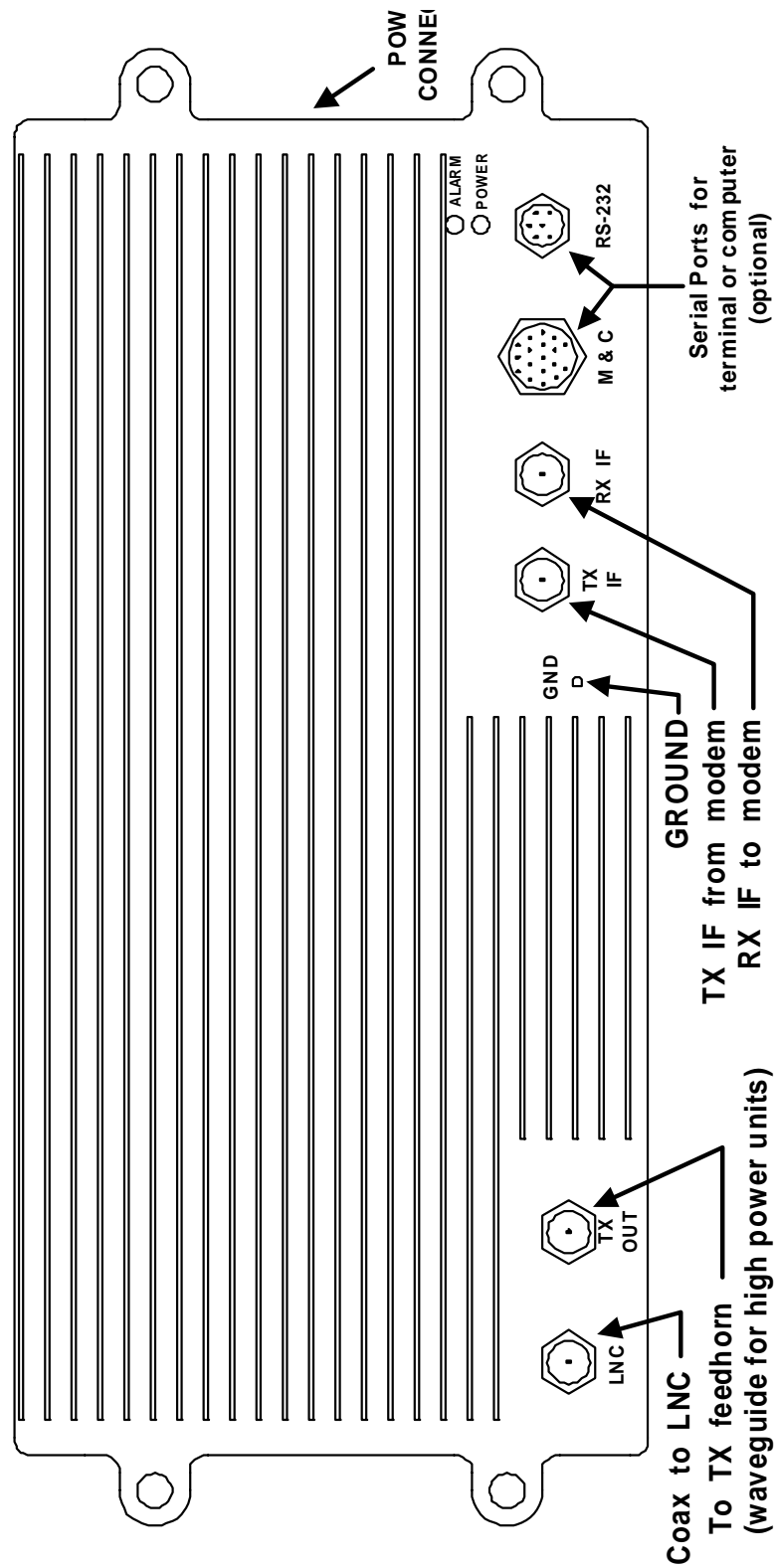

Figure 2-4. Transceiver cable connectors.

Section 3. Operation

Preliminary Steps

After the ANACOM®-C hardware is mounted and verified, the antenna must be aimed toward the desired satellite. Follow the antenna/mount manufacturer's instructions, using coordinates provided by the satellite operator. *Do not transmit until you have received authorization from the satellite network operation center, and a transmit power level from its engineering staff.*



AnaCom Transceivers are shipped from the factory with TX ON as active.

Terminal Connection and Configuration

Autolink

The AnaCom M&C features automatic baudrate sensing on the serial ports. If a wrong baudrate is detected, the M&C will drop to 1200 baud and wait for user to move to 1200 baud. AnaCom provides a CD with both our Supervisor and Supervisor Jr. software on it, that will establish a link with the ODU automatically, regardless of the last used settings.

Connect a terminal or computer running terminal emulation software to either serial port. Generally, COM 1 (the 6-pin circular connector) is used for on-site maintenance and control. COM 0 is often used in its RS-485 mode, with multi-unit, packetized protocol and differential mode signals good for moderately long distance (up to 4000 feet or 1200m) remote control. Either port or either serial protocol can be used to accomplish setup. Set the terminal to 1200 baud, eight data bits, no parity, and one stop bit (1200,N,8,1 protocol). Refer to Appendix C for wiring diagrams for the COM ports.

Frequency Programming

TXC; RXC

The transmit and receive frequencies are set independently using the TXCHAN (TXC) and RXCHAN (RXC) commands. Refer to Appendix D

for a table of channel numbers versus frequency. NOTE: Appendix D assumes an IF of 70 MHz for both TX IN and RX OUT. Add or subtract any difference between the actual IF and 70 MHz to determine the exact RF frequency employed.

TXF; RXF

Direct frequency entry in MHz can also be done by typing TXF**** or RXF**** where **** are the transceiver frequencies desired. This also assumes exactly 70MHz (or 140 MHz) TXIF & RXIF.

Operating frequencies for standard C-band channels (EC and SEC) are calculated with the following formulas:

$$f_{TX} = TX\ IF_{IN} + 5854 + Ch\# \quad \text{MHz}$$

$$f_{RX} = RX\ IF_{OUT} + 3629 + Ch\# \quad \text{MHz}$$

For negative channels:

$$f_{TX} = TX\ IF_{IN} + 5855 + Ch\# \quad \text{MHz}$$

$$f_{RX} = RX\ IF_{OUT} + 3630 + Ch\# \quad \text{MHz}$$

For example, if the following commands are given to the transceiver:

```
RXCHAN 50
```

```
TXCHAN 50
```

Then with a TX IN intermediate frequency of 72.5 MHz the result is an output frequency of 5976.5 MHz. Likewise, with an RX OUT IF of 67.5 MHz, then the received RF frequency is 3746.5 MHz.

For XC (INSAT) frequencies, the formulas are:

$$f_{TX} = TX\ IF_{IN} + (13259 + Ch\#) / 2 \quad \text{MHz}$$

$$f_{RX} = RX\ IF_{OUT} + (8859 + Ch\#) / 2 \quad \text{MHz}$$

NOTE: XC CHANNEL SPACING (STEP SIZE) IS 0.5 MHz.

For RC (Russian) frequencies, the formulas are:

$$f_{TX} = TX\ IF_{IN} + 5904 + Ch\# \quad \text{MHz}$$

$$f_{RX} = RX\ IF_{OUT} + 3579 + Ch\# \quad \text{MHz}$$

For PC (PALAPA) frequencies, the formulas are:

$$f_{TX} = TX\ IF_{IN} + 6354 + Ch\# \quad \text{MHz}$$

$$f_{RX} = RX\ IF_{OUT} + 3329 + Ch\# \quad \text{MHz}$$

Both f_{TX} and f_{RX} may be directly entered and displayed via the M & C by using the TXFREQ and RXFREQ commands. These commands will change the terminal display from channel number to RF frequency. These frequencies assume exactly 70 MHz IF.

Antenna Adjustment



Do not transmit while adjusting the antenna position.

Follow the antenna manufacturer's instructions for antenna position adjustment. For final alignment, contact the satellite operator and get the correct polarization, azimuth, and elevation of the satellite and also confirm the desired transponder is operational.

Apply power to the ANASAT®-C. While the transceiver requires about 5 minutes for the OCXO to reach full stability, antenna adjustments may be performed by monitoring other signals, such as beacons, immediately.

Connect a spectrum analyzer to the RX IF output. Set the ANASAT®-C to the desired frequency using the RXCHAN (or RXFREQ) command, as described above. While monitoring the IF output for signals, slowly sweep the antenna through azimuth and elevation. Adjust antenna position for maximum signal strength.

Please note that the fan, on units so equipped, is thermostatically controlled and does not turn on when the unit is cold.

M & C Operation

Terminal Display

The M & C terminal display gives a complete accounting of transceiver alarms and status. The display is sent to the terminal every 30 seconds. This interval can be changed with the UTIMER command. (See Appendix A).

The top line shows the transceiver model and serial number.

The second line gives the primary transceiver operating parameters:

```

ANASAT 5C Transceiver  REV:04  S/N: 123456
TXREQ on|TX ON AIR
alarm status: CLEAR
                | TXCHAN 129   | RXCHAN 119
                | TXGAIN 68.0  | RXGAIN 97.5
monitor points: OSLLOCK: clear| TXLOCK: clear | RXLOCK: clear | PA1: 7.3 |
FANERR: clear | OSLPLL: 4.5 | TXPLL: 4.3 | RXPLL: 5.2 | PA2: 8.7 |
TEMP: 36C | DIP: 00000000 | TXMUTE: clear | LNCV: 13.0 | PA3: 9.8 |
XTAL: CLEAR | P12V: 13.1 | TX IN: -31 | | PA4: 10.1 |
N5V: -5.1 | P5V: 5.0 | TXout: 18 | RXout: -7 | PA5: N/A |
last reset: 52 seconds TXpeak: 18 | PA6: N/A |
DTE1: PC_MODE | UTIMER: 30.0 | TERMTYPE: TTY | ECHO on|CRLF on|BAUDRATE 1200
COMMAND>_
    
```

Figure 3-1. M & C terminal screen display.

- status of the TXREQ setting: “ON” or “OFF”

“ON” indicates the transceiver will transmit when all major transmitter alarms are cleared. This is the normal setting.

“OFF” indicates the transmitter will not turn on even if all alarms are clear.

- Transmitter status is either “TX ON AIR” or “TX OFF AIR”

The third line gives a summary alarm indication. The alarm can be “CLEAR”, “MINOR”, or “MAJOR”. See Appendix B for specific alarms.

The fourth and fifth lines give TX and RX channel (or frequency) and gain values.

- TXCHAN number is the actual transmit channel selected. Alternately, TXFREQ number is the actual transmit frequency for 70 MHz (140 MHz) input.
- TXGAIN is the actual transmit gain value selected in dB.
- RXCHAN number is the actual receive channel selected; or RXFREQ number is the actual receive frequency for 70 MHz (140 MHz) output.
- RXGAIN is the actual receiver gain value selected in dB.

The remainder for the display give detailed monitoring information as follows:

- OSL LOCK gives alarm status of the OSL phase locked loop; NORMAL or FAULT
- TXLOCK gives alarm status of the transmit phase locked loop; NORMAL or FAULT
- RXLOCK gives alarm status of the receive phase locked loop; NORMAL or FAULT
- FANERR gives alarm status of the cooling fan (ANASAT-10C and ANASAT-20C only).
- OSLPLL shows the actual VCO control voltage of the offset loop.
- TXPLL shows the actual VCO control voltage of the TX synthesizer.

- RXPLL shows the actual VCO control voltage of the RX synthesizer.

- TEMP shows the internal heat sink temperature in °C.

- TXMUTE gives the status of the TX override circuits, any of which will turn off the transmitter.

- LNC shows the LNC supply voltage.

- XTAL gives the status of the internal reference crystal. The two possible status are WARMING or NORMAL. By default, WARMING will disable the transmitter.

- P12V shows the internal 13 volt power supply voltage.

- P5V shows the internal 5 volt power supply voltage.

- N5V shows the internal –5 volt power supply voltage.

- UTIMER gives the present value of the user timer which controls the cycle time of the display in seconds.

- TXin shows the approximate transmitter input (TX IF) power level in dBm.

- TXout shows the approximate transmitter output power level in dBm.

- TXpeak shows the recent (60 sec) peak transmitter output power level in dBm.

- RXout shows the approximate composite receiver output power level in dBm.

- TERMTYPE gives the present terminal type selection. Options are: “TTY”, “VT52”, and “VT100”.

- ECHO gives the present setting for the terminal echo function. When “ON”, the serial port will echo all characters typed. When this parameter is “OFF” then the port will not echo characters.

- CRLF gives the present setting for the serial port to issue a line feed (LF) after each carriage return(CR). Options are “ON” or “OFF”.

- BAUDRATE shows the present terminal communications speed setting in bits per second (bps).

- PA1 through PA6 gives the voltages for each stage of the transmitter power amplifier. Note that some low power models do not use all six voltages. As a special case, the 0dBm uses PA1 through PA6 to display up to six different status or voltage points on an external high power amplifier (HPA).

Gain Adjustments

Transmitter Gain

After the transceiver has warmed up for at least 5 minutes (OCXO warm-up) the transmitter may be activated. Set the transmit gain to achieve the desired output level (in dBm) with the transmit gain control, TXGAIN. Output power is selectable in 1 dB steps. Smaller steps can be entered, for example: TXG 62.5 and the M&C will attempt to provide that gain as close as possible.

Maintaining proper output power is vital for maximizing signal-to-noise ratios over the radio path. Low power levels produce noisy signals; excessive power robs downlink strength from other stations sharing the transponder.

Adjust the transmitter gain to attain the desired output power level. Use a calibrated watt meter for this task. The M&C gives an uncalibrated reading of output power which is good for long term monitoring, but it is not intended to replace a calibrated meter.

When transmitting multiple carriers, run the output power with an output back-off sufficient to meet the spectral density mask requirements.

Caution: It is recommended that the transmitter not be driven into saturation for long periods of time. The input power in dBm plus the requested TX gain in dB should not exceed the P1dB rating for the given transmitter.

TX input (dBm) + TX Gain (dBm) <= TX p1dB rating (dBm)

Receiver Gain

Set receive gain by monitoring RX IF output level and adjust the RXGAIN parameter via the terminal. RXGAIN allow adjustment over a 15dB range, from 85dB to 100dB (including LNC gain), in 1 dB steps. Smaller step sizes can be entered, for example: RXG 87.5

Receiver gain should be set to a value where the desired receive signal is centered in the modem AGC range. At the same time, the composite signal, containing all received signals in the transceiver passband, must not exceed the modem's maximum rated input level. Account for IF cabling losses when calculating the RXGAIN value.

RX IF output is monitored by the M & C unit; a Summary alarm is generated if this output level drops below a specific level (generally when the LNC is not attached). The M & C uses an internal detector on the RX output to monitor RX output power. This is shown in the terminal display window in dBm. The RX output power value shown is not accurate enough to rely on for measuring the desired signal. The detector is broadband and will respond to ALL signals in the transponder, including noise.

Receiver gain setting is usually not as critical as transmit gain: excessive gain may cause modem receiver overloading and result in distortion on the received signal; insufficient gain presents reduced signal-to-noise ratios. Ideal RX gain puts the desired IF signal amplitude near the midpoint of the modem AGC range.

Basic M & C Commands

1. Using the terminal, configure the transceiver to the proper frequency:

RXCHAN nnn nnn ranges from 1 to 501

TXCHAN nnn nnn ranges from 1 to 501

(see Appendix D).

2. Configure receive gain and transmit gain.

RXGAIN nnn nnn ranges from 85 to 100
 in 1 dB steps

TXGAIN nn nn ranges from:

0 to 36 [0C]	60 to 86 [70C, 80C]
44 to 70 [2C]	61 to 87 [100C]
48 to 74 [5C]	62 to 88 [125C]
51 to 77 [10C]	63 to 89 [150C]
54 to 80 [20C]	64 to 90 [180C]
57 to 83 [30C, 40C]	64 to 90 [200C]
58 to 84 [50C, 60C]	

*NOTE: GAIN SETTINGS AND POWER READINGS ARE NOT
INTENDED TO REPLACE A CALIBRATED POWER METER.*

Transmit gain is adjustable in 1 dB steps;
to program 60 dB of gain, merely type:

```
TXGAIN 60 <cr>
```

For 60.5 dB of gain, type:

```
TXGAIN 60.5 <cr>
```

*NOTE: THE DECIMAL POINT IS ONLY NECESSARY WHEN
0.5dB OF GAIN RESOLUTION IS ATTEMPTED. FRACTIONAL VALUES
MAY BE REQUESTED, BUT ONLY THE NEAREST WHOLE VALUE WILL
BE DISPLAYED.*

3. Enable the Transmitter:

```
TX ON            (TX OFF takes the  
                  transmitter OFF air)
```

ANASAT[®]-C Quick Start Guide

1. Mount the transceiver and the LNC on the antenna.
2. Connect the cables as shown in the drawing (See page 2-5 of Operations Manual).
3. Connect a terminal to a serial port, configured to 1200bps, 8 data bits, no parity, 1 stop bit, CR/LF Off. Connection diagrams are in Appendix C.
4. Install a proper power connector on the (included) power cable. Plug the cable into 110 or 240VAC, 50/60Hz. Verify the green LED on the transceiver is blinking, indicating normal internal operation. The red LED is usually OFF. If illuminated, it indicates an alarm condition requiring attention. Refer to the ALARM command for details (Appendix A).
5. Using the terminal, configure the transceiver to the proper frequency:

```
RXFREQ nnnn    (nnnn in MHz —see Appendix D for channel)
TXFREQ nnnn    (nnnn in MHz —see Appendix D for channel)
```
6. Configure receive gain and transmit output power:

RXGAIN	nnn	nnn ranges from	85 to 100		
TXGAIN	nn	nn ranges from:	10 to 36 [0C]	44 to 70 [2C]	
			48 to 74 [5C]	51 to 77 [10C]	
			54 to 80 [20C]	57 to 83 [30C, 40C]	
			58 to 84 [50C, 60C]	60 to 86 [70C, 80C]	
			61 to 87 [100C]	62 to 88 [125C]	
			63 to 89 [150C]	64 to 90 [180C]	
				64 to 90 [200C]	
7. Enable the Transmitter:

```
TX ON    (TX OFF takes the transmitter OFF air)
```

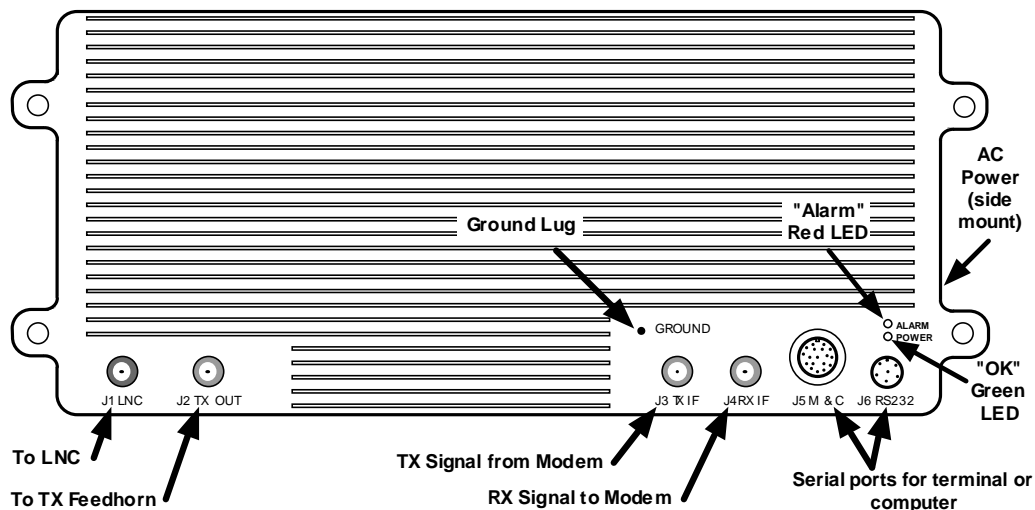

Section 4. Theory of Operation

The ANASAT[®]-C transceiver outdoor unit (ODU) consists of five major blocks, as shown in Figure 4-1. These blocks are:

- Low Noise Converter (LNC) and Transmit Reject (TR) filter
- Transmit/Receive Converter
- Power Amplifier (PA)
- Monitor and Control Unit (M & C)
- Universal Input switch-mode power supply

Signal Path

Receive signals from the antenna feed through CPR-229G waveguide into the Transmit Reject (TR) Filter, which prevents the transmit signal and receiver image frequencies from passing into the Low Noise Converter (LNC). The LNC amplifies and mixes the C-band receive signal, outputting an L-band IF signal to the converter module. The receive converter portion of the converter module synthesizes the proper mixer frequencies for the second converter, which outputs the (nominal) 70 MHz receive output at the RX IF N-connector on the transceiver.

Transmit signals at (nominally) 70MHz are input to the TX IF N-connector on the transceiver. This signal is double converted to the desired C-band frequency in the converter module and output to the linear power amplifier (PA). PA output of up to 200W, depending upon transceiver version, feeds the antenna.

Control and Power Systems

The microprocessor-based M & C unit monitors the transceiver's parameters to insure proper operation and reliable, long term service. Two serial ports provide local or remote terminal access.

Power distribution is controlled with each of several supply voltages and currents carefully monitored. An active feedback negative bias voltage supply guarantees proper control of PA power.

Two LEDs, a flashing green indicating proper operation and a red warning of a Summary alarm, are mounted on the transceiver for status indication.

Low Noise Converter and Transmit Reject Filter

The receive signal from the antenna's feed horn is fed via a CPR-229G waveguide coupler into the (optional) Transmit Reject (TR) filter (refer to Figures 4-2 and 4-3). This filter attenuates both the transmit signal and the receiver's image (LO + IF), preventing severe overload of the LNC. TR filter passband characteristics are shown in Figure 4-4.

The LNC is bolted to the TR filter at the feed horn of the antenna and consists of two blocks: a C-band low noise amplifier (LNA) and a block converter that mixes the C-band receive signal with the 5 GHz local oscillator from the receive converter module to produce an L-band output.

The LNA consists of a three-stage GaAs FET preamplifier. Negative gate bias for the GaAs FETs is generated inside the block converter.

If the LNC has been purchased with the RF port option, then the signal at its RF frequency is available with about 20 dB of gain.

The amplified C-band signal is mixed with the 5 GHz local oscillator (LO) signal from the converter module in the transceiver. A filter passes the difference frequency and outputs this L-band signal to an N-connector. A cable carries this output to the converter module inside the transceiver.

Only one coaxial cable is needed between the transceiver and the LNC. This cable carries three signals:

- L-band signal output from the LNC
- »5 GHz LO input from the converter
- +13V DC power from the converter module.

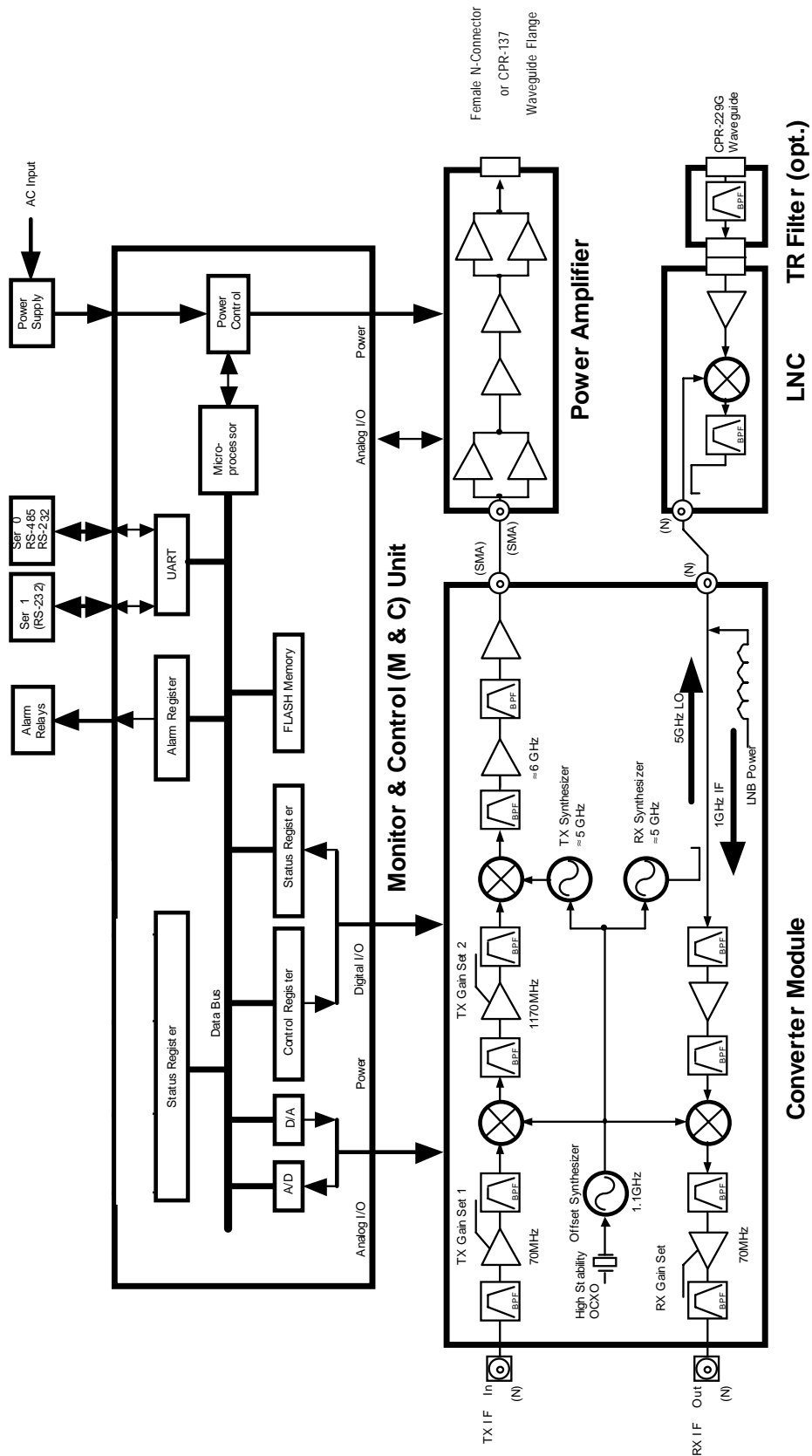

Figure 4-1. ANASAT®-C Transceiver Block Diagram



Figure 4-2. The LNC

Combination and separation are accomplished with an inductor for the supply voltage and a pick-off coupling for the LO.

Converter Module

The converter module (Figure 4-5) is located inside the transceiver and consists of two sections, the receive converter and the transmit converter. The converter module takes an extremely stable 10 MHz reference signal from the Monitor & Control unit and synthesizes all necessary mixing frequencies.

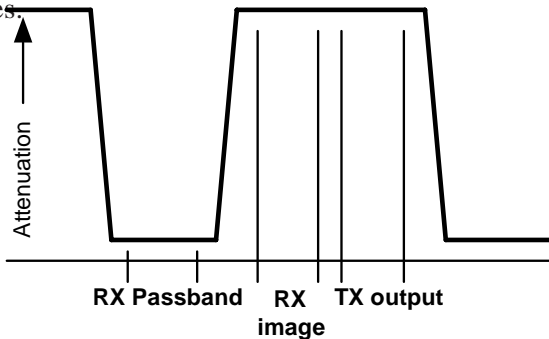

Figure 4-4. TR Filter Passband Characteristics.



Figure 4-3. The Optional TR Filter

Receive Converter Signal Path

The receive converter takes its input from the LNC via an N-connector on the transceiver (refer to Figure 4-6). A short coaxial cable connects the type-N connector on the heat sink to the converter unit itself. A diplexer at this input allows this single connector to perform three functions: signal IF input from the LNC, LO output to the LNC, and DC power to the LNC.

The L-band receive signal is extracted by the input diplexer and is filtered by a mechanically-tuned 6-pole filter. A single-stage amplifier provides +10 dB of gain. Another mechanical filter cleans the signal before it is mixed with a 1.1GHz LO frequency, producing the (nominal) 70 MHz receive output. An L-C network selects only the 70 MHz mixer output and passes this signal to a variable gain amplifier. This variable gain amplifier is adjustable over a 15dB range and is operator-adjustable by terminal commands via the M & C unit. A final LC bandpass filter

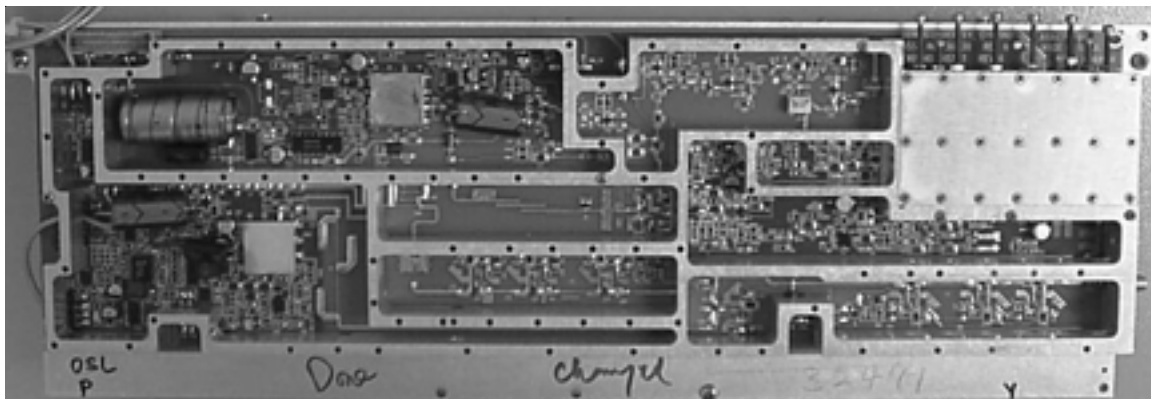

Figure 4-5. Converter Module Assembly.

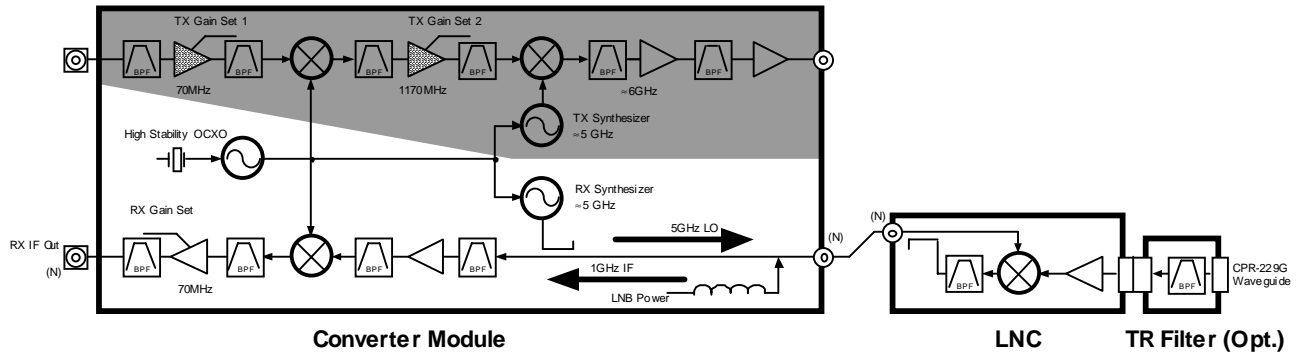

Figure 4-6. Converter Module, Receive Portion.

connects the variable gain amplifier to the 50W N-connector output on the ODU. An external 50W to 75W transformer is available from ANACOM as an option.

The +13V DC supply to the LNC is fused with a self-resetting “polyfuse”. This polyfuse is located on the M & C board.

Frequency Synthesizers

The converter module generates all necessary frequencies with phase-locked-loop (PLL) synthesizers. All PLLs are referenced from a single 10 MHz clock mounted on the M & C board. The master oscillator is a highly stable 10 MHz oven controlled crystal oscillator (OXCO) accurate to 1×10^{-8} Hz (0.01 Hz at 10MHz). This oscillator is fine tuned to compensate for normal aging effects automatically from the M & C unit.

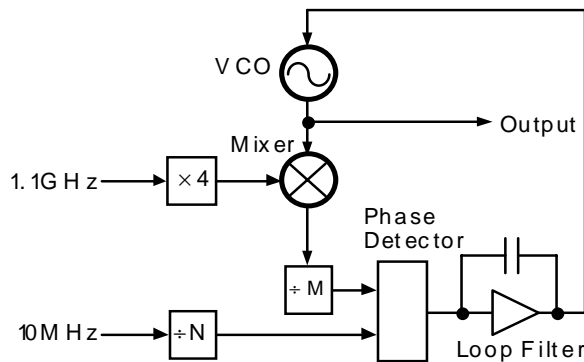

Figure 4-7. Phase-Locked Loop Frequency Synthesizer Block diagram.

Offset Loop

The first synthesized frequency is the 1.1GHz offset loop signal that is used by both the transmit and the receive converters. This signal is split and fed to the second receive mixer and the first transmit mixer.

Receive Synthesizer

The receive synthesizer generates the tunable $\gg 5$ GHz LO used by the LNC. Referring to Figures 4-6 and 4-7, the 1.1 GHz offset loop signal is applied to a x 4 multiplier and mixed with a 5 GHz VCO. The resulting 300 MHz to 800 MHz output is fed into a programmable divider and fed to a phase detector that compares it to the 10 MHz reference clock. Phase detector output voltage is filtered and drives a 2.3 GHz to 2.7 GHz VCO. This frequency is doubled and fed into the previously mentioned mixer, closing the loop. Other C-band frequencies are generated by an almost identical circuit.

Transmit Synthesizer

The transmit synthesizer generates a tunable 4.75 GHz to 5.25 GHz LO used by the second transmit mixer to produce the final transmit output frequency. Referring to Figures 4-7 and 4-8, the 1.1 GHz offset loop signal is applied to a x 4 multiplier and mixed with a 5 GHz VCO. The resulting 300 MHz to 800 MHz output is fed into a programmable divider and fed to a phase detector that compares it to the 10 MHz reference clock. Phase detector output voltage is filtered and drives a 2.3 GHz to 2.7 GHz VCO, which is frequency doubled and fed into the previously mentioned mixer, completing the loop.

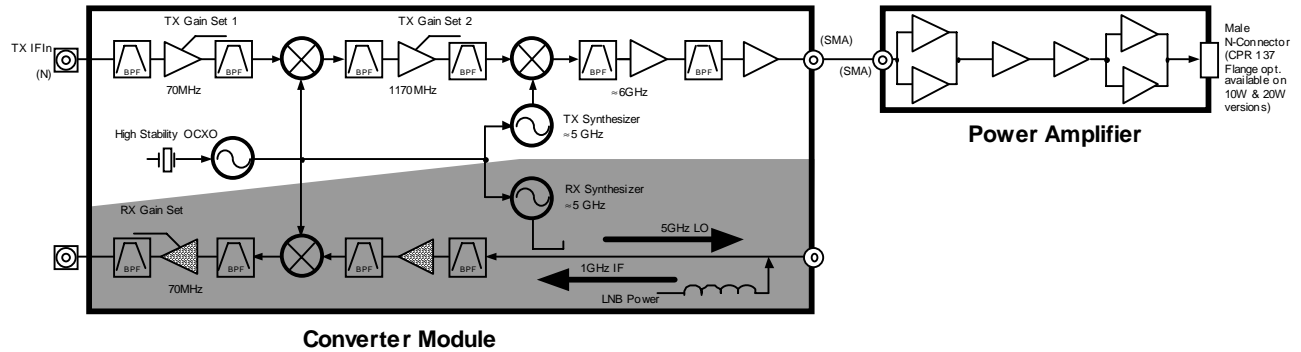

Converter Module

Figure 4-8. Converter Module, Transmit Portion.

Transmit Converter Signal Path

The Transmit converter takes the nominal 70 MHz signal input from a 50W N-connector on the transceiver (refer to Figure 4-8). (Note: an external 75W to 50W transformer is available from ANACOM as an option). This signal passes through an LC filter and into the transmit variable gain amplifier. This amplifier is gain-adjusted by a control voltage from the M & C unit, and has a gain variation of 26dB in 1dB steps. Another LC bandpass filter removes any out-of-band noise and presents the signal to the first transmit mixer. This mixer adds the 1.1 GHz offset loop frequency to the TX IF, producing a 1170 MHz nominal output. This L-band output passes through a mechanical filter into the second gain block. The signal amplitude is adjusted by a control signal from the M & C unit and the amplified signal flows through another mechanical filter.

The L-band output is now applied to the second transmit mixer, where it is combined with the 5 GHz transmit synthesizer output and becomes a C-band signal of the desired frequency. A mechanical bandpass filter selects the proper mixer product and applies it to a three-stage amplifier. A final mechanical filter is used before the transmit signal is applied to the SMA jack that couples it to the PA.

Power Amplifier

ANASAT®-C series transceivers are available with maximum transmit output powers up to 200 watts.

Sixteen different power amplifier (PA) modules are employed to economically achieve the different output ratings.

Note: The 0 dBm unit “0W” transceiver has no power amplifier. The up converter output is fed directly to the outside with a type-N connector.

Construction

The PA module is a highly linear amplifier built on soft-board Duroid™ PC board substrate material silver epoxied inside a 0.75-inch thick machined aluminum block. This assembly is bolted to the center of the transceiver heat sink for excellent thermal conductivity. Power for each stage is provided via individual feed-throughs drilled into the machined block and has separate ferrite bead isolation for each connection. Aluminum bars securely fasten the soft board into the cavity.

5 Watt Module

The 5 watt module, shown in Figure 4-9, takes its input from the transmit converter on the converter module. This input handles up to +10 dBm and is connected to the converter board via coaxial cable using SMA connectors.

Good RF grounding and thermal properties are assured by the use of Teflon® (Duroid™) PC board substrate material which is permanently attached to the cavity.

Transmit input is applied to a hybrid coupler which feeds a balanced two-transistor amplifier. A second hybrid coupler converts this balanced output to a single-ended input for the four-stage amplifier. Maximum final output power is a minimum of 5 Watts.

Output is applied to a SMA connector mounted on the soft board. A coaxial cable connects to a 50W

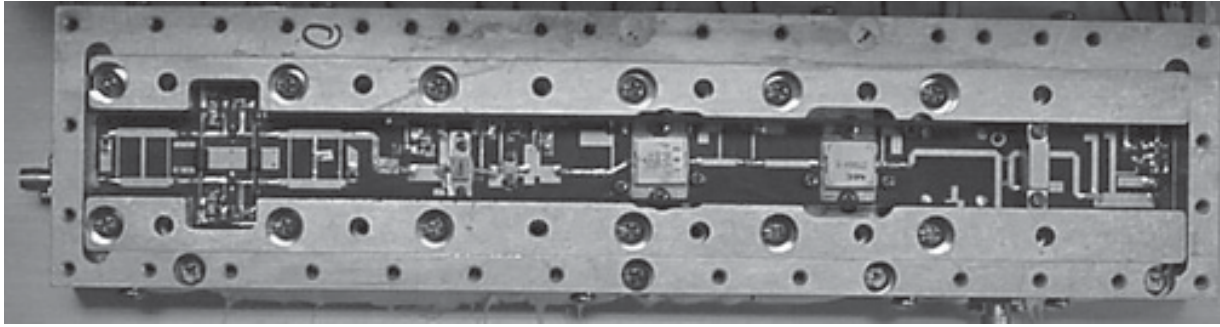

Figure 4-9 5W Power Amplifier Module.

N-connector mounted on the heat sink of the transceiver.

A directional coupler and power detector monitors the output power level and reports to the M & C unit.

40 Watt Module

The 40 watt PA module, shown in Figure 4-10, takes its input from the transmit converter on the converter module. This input handles up to +10 dBm and is connected to the converter board via semi-rigid cable using SMA connectors.

Good RF grounding and thermal properties are assured by the use of Teflon® (Duroid™) PC board substrate material which is permanently attached to the cavity.

Transmit input is applied to a hybrid coupler which feeds a balanced two transistor amplifier. A second hybrid coupler converts this balanced output to a single-ended input for the four stage amplifier.

This drive power is fed into another hybrid coupler and on into the balanced final amplifier. This balanced output passes through another hybrid to combine the signal into a single-ended 40 watt output which is fed into a female SMA connector mounted on the soft board. A coaxial cable connects to a 50Ω N-connector mounted on the heat sink of the transceiver. A directional coupler and detector diode monitors output power and reports to the M & C unit.

If the transceiver is configured with the optional CPR137 waveguide port, a waveguide launch is



DO NOT ATTEMPT TO REPAIR OR REMOVE THE P.A. CIRCUIT BOARD! SEVERE DAMAGE WILL RESULT.

mounted under the heatsink and mates to the PA module.

Power for each stage is individually filtered and applied through ferrite beads via cutouts in the aluminum housing. Both gate bias and drain power for the final three stages are fed with press-fit filtered terminals for excellent sealing and isolation.

10W, 20W, 30W, 50W, 60W, 70W, 80W, 100W, 125W, 150W, 180W and 200W

These modules are similar but offer the other output powers indicated.

Monitor and Control Unit

The monitor and control unit (M & C), Figures 4-12 and 4-13, is a microprocessor-based controller providing transceiver diagnostics, remote command, power distribution, active bias voltage for the PA, and a highly accurate and stable reference frequency.

Microprocessor-Based Functions

The heart of the M & C unit is the 80C188 microprocessor, operating at 16 MHz. It has 128K of SRAM and two 1MB FLASH electrically erasable programmable read-only memories for program and variable storage.

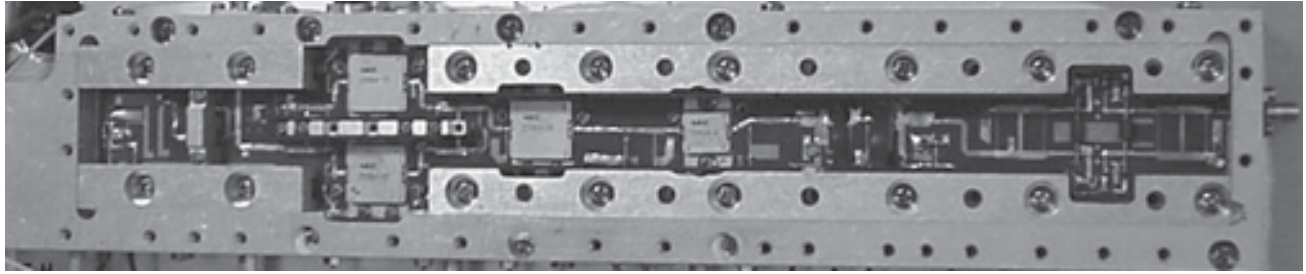

Figure 4-10 40W Power Amplifier Module.

The microprocessor allows long term, completely unattended remote operation of the ANASAT®-C transceiver. All functions are accessible remotely via either of the two serial ports, which allow remote monitoring and diagnostics as well as normal frequency and power control.

Analog-to-digital (ADC) and digital-to-analog (DAC) converters are used by the microprocessor to monitor operating parameters and control the transceiver.

Two external LEDs, a flashing green lamp indicating proper system operation, and a red one warning of a Summary alarm are controlled by the microprocessor. These lamps provide obvious, immediate status feedback to any on-site operator or maintenance personnel.

Serial Ports

Serial communications are provided through two communications ports. COM 0 is either RS-232 or RS-485 compatible. COM 1 is RS-232 compatible. Both ports allow communications rates between 300bps and 57.6kbps, and use eight data bits, no parity, and one stop bit. Both ports are set at the factory to 1200bps.

Monitor Inputs

The following analog inputs are monitored by the microprocessor via the ADC:



DO NOT ATTEMPT REPAIR OR REMOVE THE P.A. CIRCUIT BOARD! SEVERE DAMAGE WILL RESULT.

- PA temperature
- All three PLL synthesizer VCO control voltages
- PA power output
- -5V DC supply
- Each individual PA power supply
- Main +13V power supply
- M & C board +5V power supply
- LNC power supply
- TX IF power input (70 MHz)
- RX IF power output (70 MHz)

The following digital inputs are monitored by the microprocessor:

- Synthesizer lock detect alarm (monitors all three PLLs separately)
- Cooling fan failure (if fan is installed)

Control Outputs

The microprocessor controls:

- TX gain
- RX gain
- OCXO fine frequency adjust
- Transmit ON/OFF switching
- Sequenced PA power supply control
- Serial control data for the transmit and receive frequency synthesizers.

The PA power supplies are sequenced on power-up to limit the initial power surge that would otherwise result.

The programmable counters in the PLL frequency synthesizers are loaded by the microprocessor. Both are connected to the same data and clock lines, and have independent strobes.

Non-Microprocessor-Based Monitor Functions

Separate monitor functions are implemented in hardware as a fail-safe in the unlikely event of a microprocessor lock-up. These functions disable the



DO NOT ATTEMPT REPAIR OR REMOVE THE P.A. CIRCUIT BOARD! SEVERE DAMAGE WILL RESULT.

transmitter independently of any microprocessor commands.

- Heat sink overtemperature fault
- -5V GaAs FET bias supply failure



Figure 4-11 100 Watt EC Band unit

- Offset PLL failure
- Transmit synthesizer failure

Alarm Relays

Two mechanical relays are used in the ANASAT®-C transceiver for alarm indication. One is for major alarms and the other is for minor alarm conditions. The red LED mounted on the transceiver is illuminated whenever either the minor or major alarm relays indicate a problem exists.

The major alarm relay has normally-closed contacts, so it defaults to the alarm state when power is off.

The alarm relays can be re-configured via software to become summary TX and RX alarm relays. See ALARM_MODE in Appendix A.

Power Distribution

The M & C unit takes +13V DC input from the system power supply and generates several additional supplies:

- +5V for the M & C unit
- +5V for the converter unit
- +13V for programming the FLASH memory and running the LNC
- -5V for the GaAs FET active bias
- 11V for the PA (PA1 through PA6)

All supplies are regulated through low noise linear regulators. The 11V supply for the PA is actually

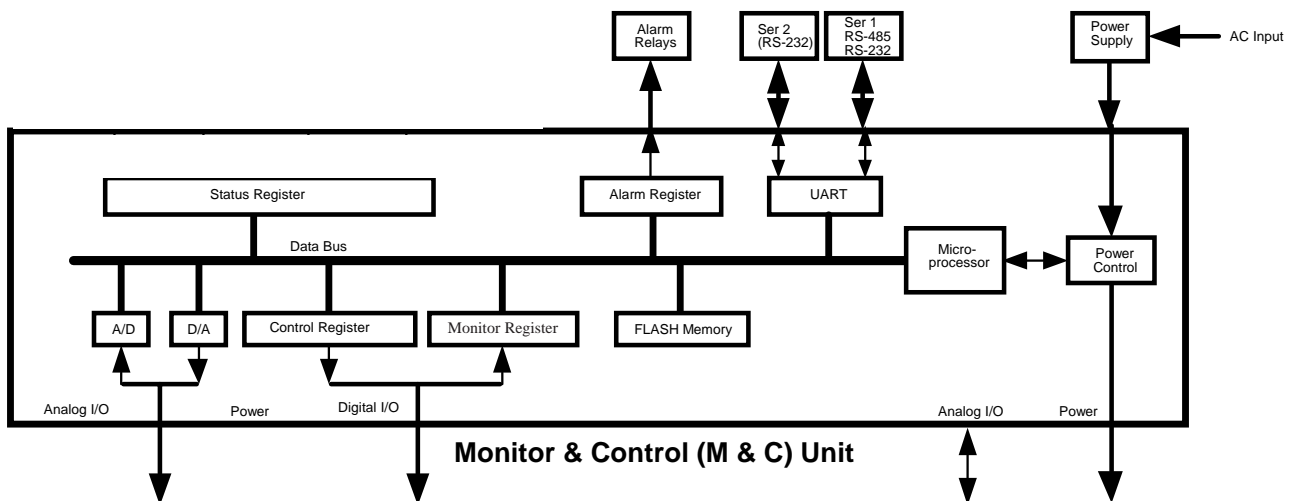

Figure 4-12. The Monitor and Control (M & C) unit.

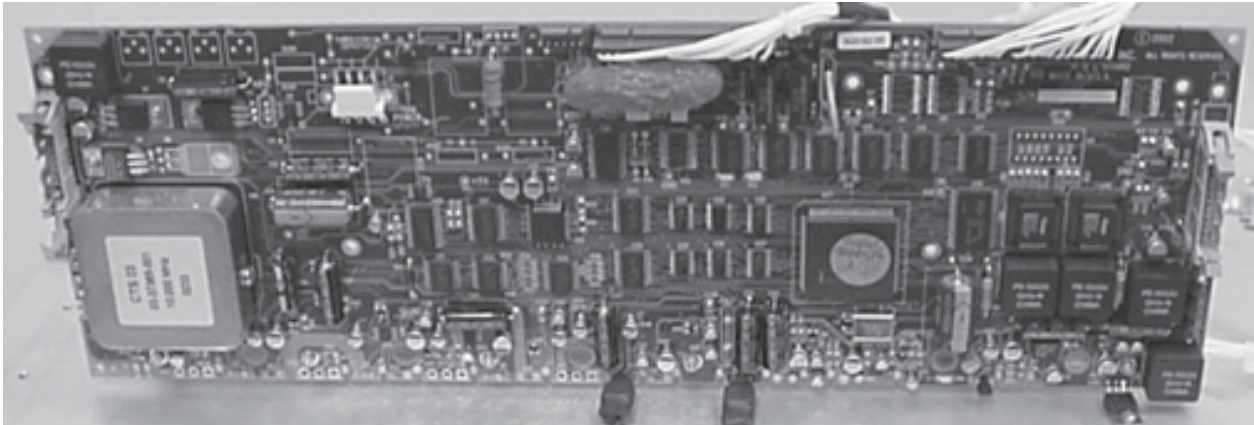

Figure 4-13 Monitor and Control Unit Board.

four, five, or six separate regulators (the number of regulators employed depends upon which transceiver PA power level used) for isolation and power surge control reasons. Voltage and/or current is monitored for each supply. Additionally, a high accuracy, temperature compensated voltage reference is employed for the DAC and ADC.

PA Active Bias Generation

The GaAs FETs used in the PA require a negative gate voltage for operation. These very expensive devices are easily destroyed with improper bias. ANASAT®-C transceivers employ an active bias circuit with feedback to automatically control the DC power consumption of each PA stage.

Microwave Synthesizer Frequency Reference

All transceiver operating frequencies are synthesized from one 10 MHz reference oscillator. This clock is a high accuracy, high stability oven controlled crystal oscillator (OCXO) module guaranteed within $\pm 1 \times 10^{-8}$ Hz. The M & C unit periodically compensates for crystal aging automatically.

If your transceiver has been ordered with the EXTERNAL 10 MHz CRYSTAL REFERENCE SWITCH option, then that option can be activated using the EXTREF command.

Example:

EXTREF ON

When active, the transceiver's synthesizers lock to the external reference. If this option has been activated, but an inadequate external reference signal is present, then the EXTREF alarm will be raised: this is a MAJOR alarm. The transceiver is not going to switch back to the internal crystal reference when this option is active but an external source is missing or inadequate. To return to conventional operation using the internal reference source, use the command:

EXTREF OFF

The minimum signal level required for an external reference is +5 dBm.

Power Supply

ANASAT®-C transceivers use a wide input voltage (100 to 240VAC, 50/60Hz) switching power supply to develop the +13V used as the internal power source. An internal circuit senses which input voltage range is being used and automatically switches modes. Figure 4-14 a & b in next page shows how the power supply is mounted in the transceiver (sample 5W and 40W). The AC input is connected via a 4-pin circular connector.

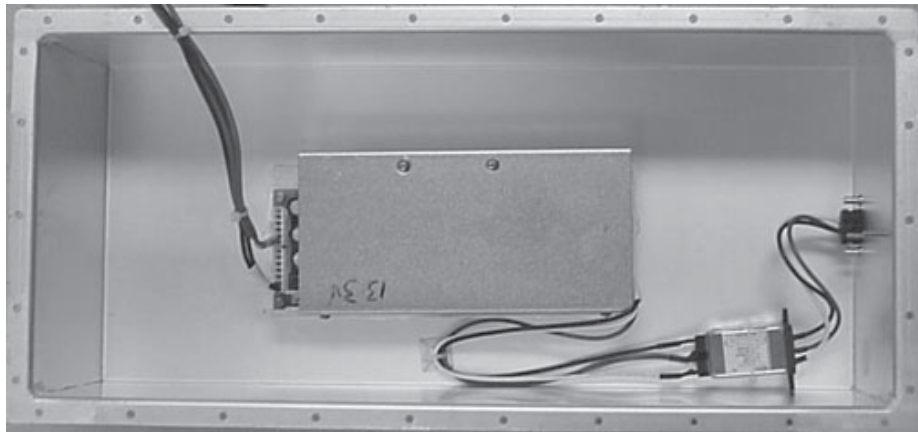

Figure 4-14 a

The 13V Power supply is mounted inside the cover, Model 5Watt.

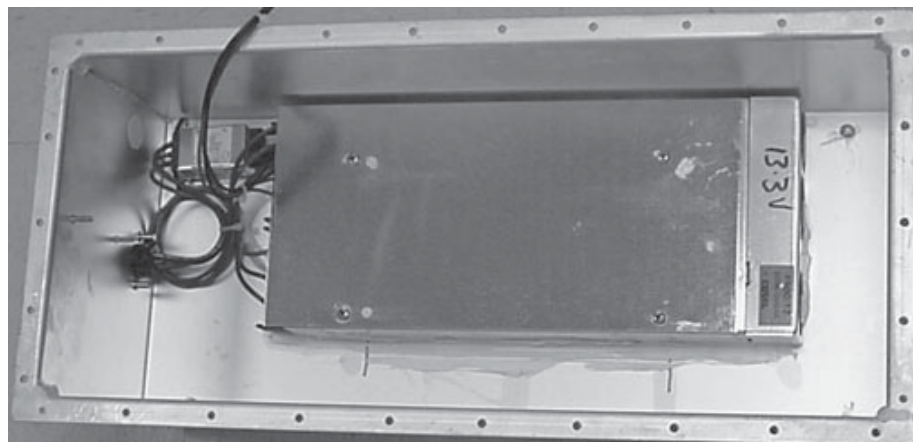

Figure 4-14 b

The 13V Power supply is mounted inside the cover, Model 40Watt.

Section 5. Maintenance

ANASAT®-C series transceivers are designed for a minimum of maintenance. The on-board microprocessor monitors all vital functions to ensure proper operation. Periodic scheduled maintenance is not required.

Aging of the ovenized reference oscillator is automatically microprocessor compensated, further reducing maintenance worries.

Various operational voltages may be monitored via either serial port.

At the time of installation, it is recommended that each of these points be recorded. If problems occur later, these initial recorded values can be of great help troubleshooting the system. The following table may be used to record the operating parameters. Note that several of these values are specific to the setup. For example, the RX SYNTH voltage will change if RX CHAN (the receive frequency) is changed.

Parameter	Normal Range	Installed Value
TXCHAN	<i>model dependent</i>	
TXGAIN	<i>model dependent</i>	
RXCHAN	<i>model dependent</i>	
RXGAIN	85 to 100	
OSLPLL	1.9 to 11 volts	
TXPLL	1.9 to 11 volts	
RXPLL	1.9 to 11 volts	
TEMP	-30 to +50	
LNCV	+11 to +14	
P12V	+12 to +14	
P5V	+4.7 to +5.3	
N5V	-5.3 to -4.3	
TXin	-40 to -20 dBm	
TXout	<i>model dependent</i>	
RXout	<i>site dependent</i>	
PA1	N/A	
PA2	N/A	
PA3	N/A	
PA4	N/A	
PA5	N/A	
PA6	N/A	

LNC Replacement

Although the ANASAT-C family of transceivers is designed to need no normal maintenance, if it ever becomes necessary to replace the LNC, this procedure may be accomplished in the field with a minimum of equipment.

Two indications point to a faulty LNC; although a faulty LNC cable can also cause these symptoms.

- 1) Improper LNC Voltage
- 2) Receive IF output level low

Both of the above parameters are reported by the remote M & C terminal display.

LNC Replacement Procedure



Transmitter RF output power levels are adequate to cause blindness or other serious injury to body tissues. Use caution when working around the transceiver or antenna when the transmitter is active.

- 1) Remove power from the transceiver.
- 2) Disconnect the coax cable to the N-connector on the LNC.
- 3) Unbolt the LNC from the antenna mount. Save the weather tight gasket for reuse.
- 4) Attach the new LNC to the flange, using the gasket.
- 5) Reconnect the coax cable to the LNC N-connector.
- 6) Reapply power.
- 7) Verify receive gain with a known signal.

Checking Receive Gain

After the LNC is replaced, the system gain calibration may be affected. Check receive gain with a known signal.

- 1) Connect a satellite modem or a spectrum analyzer to the transceiver IF output (RXIF).
- 2) Monitor RXIF output from a known signal source (satellite or signal generator source).
- 3) Connect a terminal to the RS-232 or M & C ports on the transceiver. Using the command RXGAIN nnn (see Appendix A), adjust receive gain until the modem or spectrum analyzer shows an acceptable signal level.
- 4) If necessary, use the OFFSET_RXG command for accurate receive gain correlation (see Appendix A for details).

LIMITED WARRANTY

If this product should fail due to defects in materials or workmanship, AnaCom, Inc., will, at its sole option, repair or replace it with new or rebuilt parts free of charge for a period of two (2) years from the date of shipment from the AnaCom factory. This warranty covers only failures due to defects in materials and workmanship that occurs during the period of the warranty. It does not cover damage that occurs during shipment, failure caused by operation of the product outside the published electrical or environmental specifications, or malfunctions caused by misuse of the product. Expendable components are not covered under this warranty.

In order for the customer to exercise their rights to repairs under the warranty, the customer must first contact AnaCom to obtain a repair authorization number (RMA). If it is necessary to return the product for repair, the customer is responsible for paying the cost of shipping it to AnaCom. AnaCom will pay the cost of shipping the product back to the customer when the repairs are completed. All import duties, customs fees, taxes of any kind, or any related fees are the sole responsibility of the customer.

Spare parts, repairs, or replacements are warranted to be free from defects in material or workmanship for ninety (90) days or the remainder of the limited warranty period, whichever is longer.

There are no express or implied warranties except as listed above. In no event shall AnaCom be liable for special, incidental, or consequential damages arising from the use of this product, or arising out of any breach of this warranty. All express and implied warranties, including the warranties of merchantability and fitness for a particular purpose, are limited to the applicable warranty period set forth above. No employee or representative of AnaCom is authorized to modify this warranty or AnaCom's standard warranty for any product.

Non-warranty repair service is available from AnaCom for a nominal charge. Non-warranty repair service can be obtained by contacting AnaCom and requesting a return authorization number (RMA), as described above. The customer is responsible for paying the cost of the shipping to and from AnaCom for any non-warranty repairs. Non-warranty repair service will be available for any AnaCom product for a minimum of five years from the date of its first shipment from AnaCom's factory.

Appendix A. M & C Command Set

The transceiver will not respond to any command until a carriage return has been entered, terminating the command input. Multiple commands may be entered before a carriage return, using “;” as a delimiter.

Example:

```
TXCHAN 54; RXCHAN 36; SAVE
```

will set the transmit channel to 54, the receive channel to 36 and save these changes to a FLASH EEPROM. A transceiver response to user input can also be delimited in similar fashion.

If a command is not recognized, an error message is returned. For example, if “foo <cr>” is entered, the following is returned:

```
??????? foo
```

Alphabetical Listing of M & C Commands

<u>Command</u>	<u>Page</u>
ALARMS	A-2
ALARM_MODE	A-3
BAUDRATE	A-3
CLEAR_PASSWORD	A-3
CLS	A-3
CRLF	A-3
DTE	A-3
DTE0	A-3
DTE1	A-3
ECHO	A-4
EXTREF	A-4
INFO	A-4
LABEL	A-4
LOCK PASSWORD	A-4
MODE	A-4
MODEM_MODE	A-4
MODEM_STRING	A-5
MSG	A-5
OFFSET	A-5
PC_MODE	A-5
PORT_TO_PORT	A-5
REFRESH	A-5
RESET	A-5
RXCHAN	A-6
RXGAIN	A-6
SAVE	A-6
SET_PASSWORD	A-6
TERMTYPE	A-6
TX	A-6
TXREQ	A-6
TXREQUEST	A-6
TXCHAN	A-7
TXFREQ	A-7
TXGAIN	A-7
UNLOCK PASSWORD	A-7
UTIMER	A-7
WARMUP	A-7
TXD; TXDAC	A-7
RXD; RXDAC	A-7

ANASAT® - C Band**M & C Commands**

ALARMS

This command returns a list of raised alarms for the given transceiver. The possible alarms are: WARMING, FANERR, OSLOCK, TXLOCK, RXLOCK, UCMUTE, PATEMP, TXOUT, P12V, PA, N5V, OSLPLL, TXPLL, RXPLL, P5V, LNCV, PROMERR and RXOUT.

If there are no alarms then "ALARMS CLEAR" is returned. Status of all individual alarms is evaluated ten times a second.

Alarms are categorized as **MAJOR** and **MINOR**, major alarms cause the external red LED on the transceiver to begin flashing. If there are no alarms, the status of the transceiver is CLEAR.

MAJORALARMS

OSLOCK	raised when the OFFSET PLL has lost lock
TXLOCK	raised when the TX PLL has lost lock
RXLOCK	raised when the RX PLL has lost lock
UCMUTE	raised when the hardware mute circuit on the M & C board is active (this includes external TX shutdown)
PATEMP	when the heat sink temperature exceeds approx 85°C
PA	raised when any active power amplifier voltage drops too low
N5V	raised when the -5 volt supply drops too far
LNCV	raised when the LNC supply voltage drops too far
RXOUT	raised when the RX IF output power becomes too low
PROMERR	raised if a write or erase operation in the PROM fails

MINOR

WARMING	when the warm-up software function is active upon reset or power cycling (power turn on)
FANERR	raised when fan current becomes too low (if a fan is installed)
TXOUT	raised when PA output is deemed by software to be too high
P12V	the primary 13V supply drops below a specified level
P5V	the 5V supply on the M & C board drops below a specified level
OSLOOP	OS VCXO voltage exceeds a specified range –may still be locked
TXLOOP	UC VCXO voltage exceeds a specified range –may still be locked
RXLOOP	DC VCXO voltage exceeds a specified range –may still be locked

There are alarm conditions which can shutdown the PA stage: WARMING and OSLOCK, TXLOCK, PATEMP, and N5V. When these alarms are active, the PA stage is shutdown via the supply lines which feed it. This may cause the PA alarm to be raised as well. The WARMUP alarm may be disabled with the WARMUP command.

ALARM_MODE [NORMAL | PROTECTION]

There are two modes for alarm relay operation: Normal and Protection. In the NORMAL mode, the relays operate as MAJOR and MINOR relays as described above. In PROTECTION mode, the relays become redefined as TX and RX summary fault relays. The relay normally called MAJOR becomes the TX relay and the relay normally called MINOR becomes the RX relay.

In normal operation, the MAJOR relay is energized so that a power fault causes the relay to relax and thus provide an alarm contact closure. The MINOR relay is normally not energized (non-alarm state). During PROTECTION operation, both relays are normally energized (no alarms). Therefore, the RX relay has reverse definition of its contacts (NO and NC) for PROTECTION operation compared to its NORMAL operation.

BAUDRATE [300 | 1200 | 2400 | 4800 | 9600 | 19200 | 38400 | 57600]

This command sets the baudrate of the serial channel the user is presently connected to. Both serial ports have been programmed for 8 bits, no parity and 1 stop bit. These parameters are not user changeable.

CLEAR_PASSWORD PASSWORD

This command will clear an existing password. Note that the password must be given in order for it to be cleared.

CLS

In terminal mode, 25 line feeds are sent to the terminal, effectively clearing the screen. In VT52 and VT100 modes, CLS refreshes the display.

CRLF [ON | OFF]

This command is only relevant to dumb-terminal mode. It sets (or returns) carriage-return/line-feed status. "CRLF ON" will command the M & C computer to insert a line-feed in display output following a carriage return. This can be necessary to make some terminal displays operate properly. In other cases this would be redundant.

DTE**DTE0 [COMMAND]****DTE1 [COMMAND]**

These commands return a string of data regarding the specified serial port. If no port is specified then the present serial port is used.

Using DTE0 and DTE1 it is possible to change some of the serial port parameters for the serial port other than the one the operator is presently connected to. This could be especially useful for baud rate. Example of operator input from a terminal attached to serial port 0:

```
dte1 baudrate 19200
```

The valid commands which can be used in this fashion for the opposing serial port are BAUDRATE, TERMTYPE, ECHO, CRLF, MODEM_MODE, PC_MODE, and TERMINAL_MODE.

See the explanations for those commands elsewhere in this appendix.

ECHO [ON | OFF]

This command is only relevant in dumb-terminal mode. It sets (or returns) character echo mode. For example, if the operator is running a terminal emulation program on his PC with local echo disabled, type

ECHO ON

to enable echo back from the M & C computer. If the terminal is displaying doubled up characters, use ECHO OFF.

EXTREF [ON | OFF]

If ON, the ODU is programmed to accept an optional external 10MHz frequency reference source. If one is not present, a new alarm, EXTREF is raised. When an external reference signal appears while the EXTREF alarm is raised, the alarm will be dropped.

If OFF is given, then the internal source is used regardless of whether the optional reference source switch is indicating an external source is present or not.

The default setting is EXTREF OFF.

INFO

Returns information about software and hardware revision numbers.

LABEL [TEXT]

This command erases or [sets] an alphanumeric string up to 32 characters long that the user can use to “title” or describe the purpose of the given ODU.

LOCK PASSWORD

With this command most M & C functions will be locked and further user access will be denied until the UNLOCK command is given. Those commands which remain user accessible are: UNLOCK, CLS, ALARMS, and LIST.

If a password has been established with the SET_PASSWORD command then that password must be used with the LOCK command. If there is no established password (if CLEAR_PASSWORD has been used, for instance), then M & C functions will be locked; but they can be unlocked without a password. There are two solutions to the problem of having a locked unit and/or a forgotten password:

1. The unit can be reset using the internal DIP switches. See Appendix D.
2. If the unit is attached to a modem, and presently accessible remotely, telephone ANACOM.

MODE

This command returns either MODEM_MODE or PC_MODE. Example: MODE might return MODE MODEM_MODE when the user is connected to the unit via a phone line and a Hayes compatible modem.

MODEM_MODE

This command is used to tell the M & C computer that a Hayes compatible modem is attached to the serial port. The way this would be used is a user would enter this command from a PC using a null modem cable, then disconnect the PC and attach a modem directly to the port via a modem cable. RX, TX, DCD and signal GND lines must be properly connected.

Once MODEM_MODE is activated, the M&C computer will no longer display dumb terminal display updates or generate packets in packet mode until the DATA-CARRIER_DETECT line becomes active, indicating the modem is off-hook and connected to another modem.

MODEM_STRING [TEXT]

When the M & C computer is in modem mode it will periodically send a Hayes compatible initialization string of up to 40 characters to the modem to make sure it is properly configured. The user can get [set] this string via this command. The default string as part of factory settings is:

```
MODEM_STRING AT S0=1 &C1 &S0 \Q0 E0
```

MSG TEXT

This command allows an operator connected to one serial port to send an ASCII message to someone connected to the other port. A message received will appear on the other operator's screen prefixed with the prompt MESSAGE>.

OFFSET [TXGAIN | RXGAIN] [number]

This command gets [sets] a floating point offset for TX or RX calibration tables. The valid arguments are: TXGAIN, RXGAIN.

The default values for these offsets is 0. Example usage:

```
OFFSET TXGAIN 2
```

The result of this is that the output would be 2 dB greater than what would otherwise be transmitted. In other words, the TX gain range would be shifted down by two decibels. If a TXGAIN of 72 dB were requested, the calibration data interpolation would be done internally with the value of 74 dB. If the user measures the TX gain with a power meter and finds that gain is high by 1.5 dB, then he might enter:

```
OFFSET TXGAIN -1.5
```

PC_MODE

This is the converse of MODEM_MODE. At any time, the user may type PC_MODE and the M & C computer will again behave as if a PC or network is directly attached to the serial port rather than a modem.

PORT_TO_PORT [ON|OFF]

This command sets (gets) the status of the port_to_port function. When active on, then function re-transmits all serial port data from COM0 to COM1 and also from COM1 to COM0 regardless of data content. If the M & C interprets data as a legitimate command then the command is acted on. Otherwise the data is ignored by the M & C. When ON, the M & C does not issue ??????? when data is received which does not conform to a proper command.

WARNING: When this function is ON, the M & C will not automatically change baudrate to 1200 when the external data is changed to 1200.

REFRESH

This command refreshes the RF hardware to presently chosen receive and transmit channels and gain settings.

RESET

This command resets the M & C computer. Power-on time will reset to zero. Warning: RESET will shut down the transceiver momentarily.

RXCHAN [number | INC | DEC]

This command gets [sets] the receive channel number. See Appendix E for channel frequency information. *NOTE: Channel 0 is not a valid selection.*

RXGAIN [number]

This command gets [sets] receiver gain. The acceptable range is a two or three digit integer between 85 and 100 (dB).

SAVE

This command saves present M & C operating parameters to a FLASH EEPROM.

SET_PASSWORD PASSWORD PASSWORD

The M & C computer supports password control of M & C functions. One potential use of this feature would be for leaving an ODU connected to a modem on an open telephone line. A valid password must be an alphanumeric string with no imbedded blanks, and between four and eight characters long inclusive. It must be given twice to ensure accuracy.

An existing password must first be cleared before setting a new password. This is done with the CLEAR_PASSWORD command.

TERMTYPE [TTY | VT52 | VT100] (OLD UNITS, OBSOLETE)

This command is only relevant to dumb-terminal mode. It sets (or returns) the terminal emulation mode.

TTY Terminal Mode: this is a basic 80 character by 25 line ASCII “dumb” terminal mode.

VT52 Mode: This is a standard terminal emulation, more intelligent than TTY.

VT100 Mode: This is an enhanced communications terminal emulator with a fixed display window.

There are some control characters that will be filtered by the terminal driver when the M & C computer is in terminal mode. These control characters will be ignored in packet mode.

CTRL-E: This will erase the screen, similar to the CLS command.

CTRL-R: This repeats execution of the last Carriage return terminated command.

CTRL-Q: refer to the description of CTRL-S.

CTRL-S: Periodic screen updates will be squelched until the user has finished entering present command or hits CTRL-Q.

CTRL-BS: (Backspace) The present input command will be erased

TX [ON | OFF]

TXREQ [ON | OFF]

TXREQUEST [ON | OFF]

This command requests activation of the transmitter. This is done by enabling the PA supply voltages. TXREQ ON will indicate the operator’s desire to begin transmission. With no argument TXREQ simply return its present state as ON or OFF. Note that the unit will be shipped with TXREQ set to OFF .

Exactly when are we “ON AIR?” The answer is when TXREQ is ON, the hardware alarm TXMUTE is clear, and the transmitter is not software inhibited to allow the crystal reference oscillator time to warm-up at power-on. See the WARMUP command for details.

TXCHAN [number]

This command gets [sets] the transmit channel number. The acceptable range depends upon model type. See Appendix E for channel frequency information. *Channel 0 is not a valid selection.*

TXFREQ [number]

This command gets [sets] the transmit channel number. The acceptable range depends upon model type. The [number] is the actual transmit frequency output with TXIF at 70 MHz [or 140 MHz].

TXGAIN [number | INC | DEC]

This command gets [sets] or returns the transmit power amplifier gain. The acceptable range of the number is dependent upon model.

nn ranges from:

10 to 36 dB for the ANASAT 0C
44 to 70 dB for the ANASAT 2C
48 to 74 dB for the ANASAT 5C
51 to 77 dB for the ANASAT 10C
54 to 80 dB for the ANASAT 20C
57 to 83 dB for the ANASAT 30C, 40C
58 to 84 dB for the ANASAT 50C, 60C
60 to 86 dB for the ANASAT 70C, 80C
61 to 87 dB for the ANASAT 100C
62 to 88 dB for the ANASAT 125C
63 to 89 dB for the ANASAT 150C
64 to 90 dB for the ANASAT 180C
64 to 90 dB for the ANASAT 200C

UNLOCK PASSWORD

This command will unlock M & C functions for user access.

UTIMER [NUMBER]

This command is only relevant to dumb-terminal mode. It sets (or returns) the number of seconds between automatic display updates. Note that changing baud rate will automatically revert to a default appropriate for that particular baudrate.

WARMUP [ON | OFF | CANCEL]

Upon transceiver power-up, a 5 minute period will pass to allow the reference oscillator crystal oven sufficient warm up time. The unit is shipped with this flag set OFF, but can be changed by the user. Because there is no way for the M & C computer to know how long it has been off the air, a reset or momentary loss of power will cause a warm-up countdown to occur when the feature is in use. WARMUP CANCEL will terminate a warm-up countdown and immediately enable the transmitter.

TXD; TXDAC [NUMBER]

This command bypasses the transmit numerical gain compensation by the M&C. It will issue [number] 1 to 255 to the TX gain control element. This is for troubleshooting use only and transceiver should not be left in this mode as the numerical compensation (temp. + freq.) would be disabled.

RXD; RXDAC [NUMBER]

This command bypasses the receive numerical gain compensation by the M&C. It will issue [number] 0 to 255 to the RX gain control element. This is for troubleshooting use only and transceiver should not be left in this mode as the numerical compensation (temp. + freq.) would be disabled.

Appendix B. Alarm List

The ANASAT-C transceiver features sophisticated internal monitoring. If an abnormal condition occurs, a description of the abnormality is sent via the M & C serial port to the operator's console.

These alarms are divided into two categories: major alarms and minor alarms. When a TX major alarm condition is detected, the transmitter is immediately pulled OFF the air. An advisory message is sent to the operator via the serial port and the red ALARM LED, visible from outside the transceiver, begins flashing. Most major alarms are generated directly by hardware detectors inside the unit. Minor alarms do not disable the transmitter or light the LED, but still cause an advisory message on the serial port. Most minor alarms are generated by M & C software routines which look for out of tolerance conditions.

MAJOR ALARMS	
OSLOCK	the OS PLL is not locked
TXLOCK	the TX PLL is not locked
RXLOCK	the RX PLL is not locked
PATEMP	the PA heat sink temperature becomes excessive
PA	one of the PA voltages is too low or too high
N5V	the -5 volt supply is out of tolerance
LNCV	the LNC supply voltage is too low
PROMERR	the M & C PROM checksum fails
RXOUT	the RX output noise floor becomes too low
-	external power loss

MINOR	
WARMING	the warm-up software function is enabled upon reset or power-up
FANERR	fan fails (if a fan is installed)
TXMUTE	when the TX is disabled (internally by alarms or externally)
P12V	the primary +13V supply is too low
P5V	the +5V supply on the M&C board is too low
OSLPLL	OS VCO voltage is out of range — can still be locked
TXPLL	UC VCO voltage is out of range — can still be locked
RXPLL	DC VCO voltage is out of range — can still be locked

ALARMS WHICH TURN OFF TRANSMITTER	
WARMING	software settable to mute the TX during the warmup period, or not
PATEMP	PA temperature is excessive. Automatically resets when cooler
TXMUTE	when the TX is disabled (internally by alarms or externally)
OSLOCK	OS PLL is not locked
UCLOCK	UC PLL is not locked
N5V	the -5V supply failed. Probable PA damage if PA is not shut down.

For situations when the ALARM_MODE is set to PROTECTION, the alarm relays are re-defined as TX and RX alarm relays instead of MAJOR and MINOR. The M & C software still considers the alarms as either major or minor and will communicate alarms via the serial ports and the front panel red LED as major or minor.

In PROTECTION mode, the alarm relays will engage based on the following alarm list:

TX	
OSLOCK	the OS PLL fails to lock
TXLOCK	the TX PLL fails to lock
PATEMP	the PA temperature is too high
N5V	the -5V supply is out of tolerance
PA	one of the PA supply voltages is out of tolerance
-	external power loss

RX	
LNCV	LNC voltage too low
OSLOCK	OS PLL is not locked
RXLOCK	RX PLL is not locked
RXOUT	RX output noise floor is too low (low gain)
-	external power loss

Appendix C. Serial Port Wiring

COM1, 6-Pin Circular Weathertight Connector

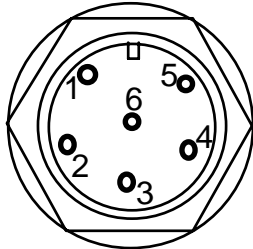

Cable Wire View

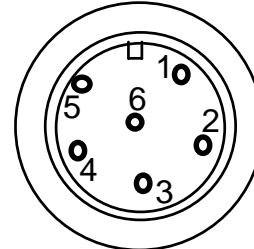

Cable End View

Pin	Signal	Description
1	DTR	Data Terminal Ready
2	DCD	Data Carrier Detect
3	DSR	Data Set Ready
4	RXD	Receive Data
5	TXD	Transmit Data
6	GND	Ground

Note dimple next to pin 1

COM0, 18-Pin Circular Weathertight Connector

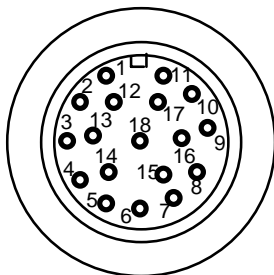

Cable Wire View

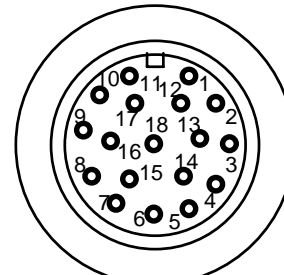

Cable End View

Pin	Signal	Description	Pin	Signal	Description
1	RY1NO	Minor Alarm Normally Open	10	RX+	Differential Receive Data
2	RY1NC	Minor Alarm Normally Close	11	RX-	Differential Receive Data
3	RY1C	Minor Alarm Common	12	RS485	RS485 Jumper (open for 232)
4	RY2NO	Major Alarm Normally Open	13	TXM	TX Mute*
5	RY2NC	Major Alarm Normally Close	14	DTR	Data Terminal Ready
6	RY2C	Major Alarm Common	15	DCD	Data Carrier Detect
7	P13V	+13V DC Power	16	RXD	Receive Data
8	TX+	Differential Transmit Data	17	TXD	Transmit Data
9	TX-	Differential Transmit Data	18	GND	Ground

NOTE DIMPLE NEXT TO PIN 1

RS485/RS232 Selection

(COM1, 18-Pin Connector Only)

Pin 12 of the 18-pin Weathertight circular connector is the RS485/RS232 mode select pumper pin. Connect Pin 12 to Ground (Pin 18) for RS485 operation. Leave open for RS232 operation. This has no effect on the other serial port.

Data Terminal Connection

Using a serial cable with a connector on one end that matches your terminal equipment (either a “dumb” terminal or a computer running terminal emulator or modem software), connect the 6-pin or 18-pin Weathertight circular connector to the other end, following Figure C-5 and the applicable previous table.

Alternative Alarm Relay Wiring

For protected installations, it may be desired to operate the transceiver with the alarm relays reporting separate TX and RX alarms instead of the normal Major and Minor alarms. See Appendix A for the ALARM_MODE command. When operating in PROTECTION mode, the alarm relays on the M&C connector should be wired per this chart:

Pin	Signal	Description
1	RY1NC	RX Alarm Normally Closed
2	RY1NO	RX Alarm Normally Open
3	RY1C	RX Alarm Common
4	RY2NO	TX Alarm Normally Open
5	RY2NC	TX Alarm Normally Closed
6	RY2C	TX Alarm Common

Note: Only the first 6 pins of this 18 pin connector are shown. All other pins are as shown on the previous page.

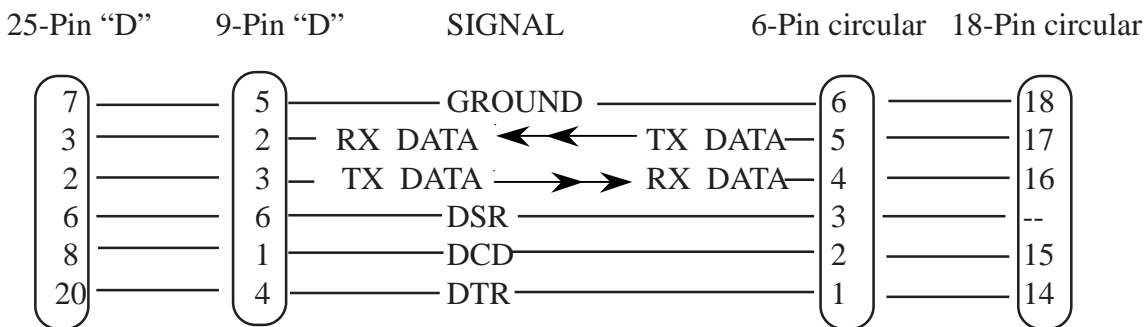

Note: Select either the 9 or 25 pin female “D” connector to match your particular data terminal. Some terminals may not need the DTR, DSR, or DCD connections.

Figure C-1. RS232 Serial Cable Connections. Computer or terminal connections.

AnaCom provides a 10 ft. long M&C cable with each unit with DB-9 & 6 pin circular connectors.

Appendix D. ANASAT[®]-EC Satellite Channels

Ch.	RX MHz	TX MHz	Ch.	RX MHz	TX MHz	Ch.	RX MHz	TX MHz	Ch.	RX MHz	TX MHz
1	3700	5925	51	3750	5975	101	3800	6025	151	3850	6075
2	3701	5926	52	3751	5976	102	3801	6026	152	3851	6076
3	3702	5927	53	3752	5977	103	3802	6027	153	3852	6077
4	3703	5928	54	3753	5978	104	3803	6028	154	3853	6078
5	3704	5929	55	3754	5979	105	3804	6029	155	3854	6079
6	3705	5930	56	3755	5980	106	3805	6030	156	3855	6080
7	3706	5931	57	3756	5981	107	3806	6031	157	3856	6081
8	3707	5932	58	3757	5982	108	3807	6032	158	3857	6082
9	3708	5933	59	3758	5983	109	3808	6033	159	3858	6083
10	3709	5934	60	3759	5984	110	3809	6034	160	3859	6084
11	3710	5935	61	3760	5985	111	3810	6035	161	3860	6085
12	3711	5936	62	3761	5986	112	3811	6036	162	3861	6086
13	3712	5937	63	3762	5987	113	3812	6037	163	3862	6087
14	3713	5938	64	3763	5988	114	3813	6038	164	3863	6088
15	3714	5939	65	3764	5989	115	3814	6039	165	3864	6089
16	3715	5940	66	3765	5990	116	3815	6040	166	3865	6090
17	3716	5941	67	3766	5991	117	3816	6041	167	3866	6091
18	3717	5942	68	3767	5992	118	3817	6042	168	3867	6092
19	3718	5943	69	3768	5993	119	3818	6043	169	3868	6093
20	3719	5944	70	3769	5994	120	3819	6044	170	3869	6094
21	3720	5945	71	3770	5995	121	3820	6045	171	3870	6095
22	3721	5946	72	3771	5996	122	3821	6046	172	3871	6096
23	3722	5947	73	3772	5997	123	3822	6047	173	3872	6097
24	3723	5948	74	3773	5998	124	3823	6048	174	3873	6098
25	3724	5949	75	3774	5999	125	3824	6049	175	3874	6099
26	3725	5950	76	3775	6000	126	3825	6050	176	3875	6100
27	3726	5951	77	3776	6001	127	3826	6051	177	3876	6101
28	3727	5952	78	3777	6002	128	3827	6052	178	3877	6102
29	3728	5953	79	3778	6003	129	3828	6053	179	3878	6103
30	3729	5954	80	3779	6004	130	3829	6054	180	3879	6104
31	3730	5955	81	3780	6005	131	3830	6055	181	3880	6105
32	3731	5956	82	3781	6006	132	3831	6056	182	3881	6106
33	3732	5957	83	3782	6007	133	3832	6057	183	3882	6107
34	3733	5958	84	3783	6008	134	3833	6058	184	3883	6108
35	3734	5959	85	3784	6009	135	3834	6059	185	3884	6109
36	3735	5960	86	3785	6010	136	3835	6060	186	3885	6110
37	3736	5961	87	3786	6011	137	3836	6061	187	3886	6111
38	3737	5962	88	3787	6012	138	3837	6062	188	3887	6112
39	3738	5963	89	3788	6013	139	3838	6063	189	3888	6113
40	3739	5964	90	3789	6014	140	3839	6064	190	3889	6114
41	3740	5965	91	3790	6015	141	3840	6065	191	3890	6115
42	3741	5966	92	3791	6016	142	3841	6066	192	3891	6116
43	3742	5967	93	3792	6017	143	3842	6067	193	3892	6117
44	3743	5968	94	3793	6018	144	3843	6068	194	3893	6118
45	3744	5969	95	3794	6019	145	3844	6069	195	3894	6119
46	3745	5970	96	3795	6020	146	3845	6070	196	3895	6120
47	3746	5971	97	3796	6021	147	3846	6071	197	3896	6121
48	3747	5972	98	3797	6022	148	3847	6072	198	3897	6122
49	3748	5973	99	3798	6023	149	3848	6073	199	3898	6123
50	3749	5974	100	3799	6024	150	3849	6074	200	3899	6124

ANASAT®-EC Satellite Channels

Ch.	RX MHz	TX MHz	Ch.	RX MHz	TX MHz	Ch.	RX MHz	TX MHz	Ch.	RX MHz	TX MHz
201	3900	6125	251	3950	6175	301	4000	6225	351	4050	6275
202	3901	6126	252	3951	6176	302	4001	6226	352	4051	6276
203	3902	6127	253	3952	6177	303	4002	6227	353	4052	6277
204	3903	6128	254	3953	6178	304	4003	6228	354	4053	6278
205	3904	6129	255	3954	6179	305	4004	6229	355	4054	6279
206	3905	6130	256	3955	6180	306	4005	6230	356	4055	6280
207	3906	6131	257	3956	6181	307	4006	6231	357	4056	6281
208	3907	6132	258	3957	6182	308	4007	6232	358	4057	6282
209	3908	6133	259	3958	6183	309	4008	6233	359	4058	6283
210	3909	6134	260	3959	6184	310	4009	6234	360	4059	6284
211	3910	6135	261	3960	6185	311	4010	6235	361	4060	6285
212	3911	6136	262	3961	6186	312	4011	6236	362	4061	6286
213	3912	6137	263	3962	6187	313	4012	6237	363	4062	6287
214	3913	6138	264	3963	6188	314	4013	6238	364	4063	6288
215	3914	6139	265	3964	6189	315	4014	6239	365	4064	6289
216	3915	6140	266	3965	6190	316	4015	6240	366	4065	6290
217	3916	6141	267	3966	6191	317	4016	6241	367	4066	6291
218	3917	6142	268	3967	6192	318	4017	6242	368	4067	6292
219	3918	6143	269	3968	6193	319	4018	6243	369	4068	6293
220	3919	6144	270	3969	6194	320	4019	6244	370	4069	6294
221	3920	6145	271	3970	6195	321	4020	6245	371	4070	6295
222	3921	6146	272	3971	6196	322	4021	6246	372	4071	6296
223	3922	6147	273	3972	6197	323	4022	6247	373	4072	6297
224	3923	6148	274	3973	6198	324	4023	6248	374	4073	6298
225	3924	6149	275	3974	6199	325	4024	6249	375	4074	6299
226	3925	6150	276	3975	6200	326	4025	6250	376	4075	6300
227	3926	6151	277	3976	6201	327	4026	6251	377	4076	6301
228	3927	6152	278	3977	6202	328	4027	6252	378	4077	6302
229	3928	6153	279	3978	6203	329	4028	6253	379	4078	6303
230	3929	6154	280	3979	6204	330	4029	6254	380	4079	6304
231	3930	6155	281	3980	6205	331	4030	6255	381	4080	6305
232	3931	6156	282	3981	6206	332	4031	6256	382	4081	6306
233	3932	6157	283	3982	6207	333	4032	6257	383	4082	6307
234	3933	6158	284	3983	6208	334	4033	6258	384	4083	6308
235	3934	6159	285	3984	6209	335	4034	6259	385	4084	6309
236	3935	6160	286	3985	6210	336	4035	6260	386	4085	6310
237	3936	6161	287	3986	6211	337	4036	6261	387	4086	6311
238	3937	6162	288	3987	6212	338	4037	6262	388	4087	6312
239	3938	6163	289	3988	6213	339	4038	6263	389	4088	6313
240	3939	6164	290	3989	6214	340	4039	6264	390	4089	6314
241	3940	6165	291	3990	6215	341	4040	6265	391	4090	6315
242	3941	6166	292	3991	6216	342	4041	6266	392	4091	6316
243	3942	6167	293	3992	6217	343	4042	6267	393	4092	6317
244	3943	6168	294	3993	6218	344	4043	6268	394	4093	6318
245	3944	6169	295	3994	6219	345	4044	6269	395	4094	6319
246	3945	6170	296	3995	6220	346	4045	6270	396	4095	6320
247	3946	6171	297	3996	6221	347	4046	6271	397	4096	6321
248	3947	6172	298	3997	6222	348	4047	6272	398	4097	6322
249	3948	6173	299	3998	6223	349	4048	6273	399	4098	6323
250	3949	6174	300	3999	6224	350	4049	6274	400	4099	6324

ANASAT[®]-EC Satellite Channels

Ch.	RX MHz	TX MHz	Ch.	RX MHz	TX MHz	Ch.	RX MHz	TX MHz
401	4100	6325	451	4150	6375	501	4200	6425
402	4101	6326	452	4151	6376			
403	4102	6327	453	4152	6377			
404	4103	6328	454	4153	6378			
405	4104	6329	455	4154	6379			
406	4105	6330	456	4155	6380			
407	4106	6331	457	4156	6381			
408	4107	6332	458	4157	6382			
409	4108	6333	459	4158	6383			
410	4109	6334	460	4159	6384			
411	4110	6335	461	4160	6385			
412	4111	6336	462	4161	6386			
413	4112	6337	463	4162	6387			
414	4113	6338	464	4163	6388			
415	4114	6339	465	4164	6389			
416	4115	6340	466	4165	6390			
417	4116	6341	467	4166	6391			
418	4117	6342	468	4167	6392			
419	4118	6343	469	4168	6393			
420	4119	6344	470	4169	6394			
421	4120	6345	471	4170	6395			
422	4121	6346	472	4171	6396			
423	4122	6347	473	4172	6397			
424	4123	6348	474	4173	6398			
425	4124	6349	475	4174	6399			
426	4125	6350	476	4175	6400			
427	4126	6351	477	4176	6401			
428	4127	6352	478	4177	6402			
429	4128	6353	479	4178	6403			
430	4129	6354	480	4179	6404			
431	4130	6355	481	4180	6405			
432	4131	6356	482	4181	6406			
433	4132	6357	483	4182	6407			
434	4133	6358	484	4183	6408			
435	4134	6359	485	4184	6409			
436	4135	6360	486	4185	6410			
437	4136	6361	487	4186	6411			
438	4137	6362	488	4187	6412			
439	4138	6363	489	4188	6413			
440	4139	6364	490	4189	6414			
441	4140	6365	491	4190	6415			
442	4141	6366	492	4191	6416			
443	4142	6367	493	4192	6417			
444	4143	6368	494	4193	6418			
445	4144	6369	495	4194	6419			
446	4145	6370	496	4195	6420			
447	4146	6371	497	4196	6421			
448	4147	6372	498	4197	6422			
449	4148	6373	499	4198	6423			
450	4149	6374	500	4199	6424			

ANASAT®-SEC Satellite Channels

Ch.	RX MHz	TX MHz	Ch.	RX MHz	TX MHz	Ch.	RX MHz	TX MHz	Ch.	RX MHz	TX MHz
-75	3625	5850	-25	3675	5900	26	3725	5950	76	3775	6000
-74	3626	5851	-24	3676	5901	27	3726	5951	77	3776	6001
-73	3627	5852	-23	3677	5902	28	3727	5952	78	3777	6002
-72	3628	5853	-22	3678	5903	29	3728	5953	79	3778	6003
-71	3629	5854	-21	3679	5904	30	3729	5954	80	3779	6004
-70	3630	5855	-20	3680	5905	31	3730	5955	81	3780	6005
-69	3631	5856	-19	3681	5906	32	3731	5956	82	3781	6006
-68	3632	5857	-18	3682	5907	33	3732	5957	83	3782	6007
-67	3633	5858	-17	3683	5908	34	3733	5958	84	3783	6008
-66	3634	5859	-16	3684	5909	35	3734	5959	85	3784	6009
-65	3635	5860	-15	3685	5910	36	3735	5960	86	3785	6010
-64	3636	5861	-14	3686	5911	37	3736	5961	87	3786	6011
-63	3637	5862	-13	3687	5912	38	3737	5962	88	3787	6012
-62	3638	5863	-12	3688	5913	39	3738	5963	89	3788	6013
-61	3639	5864	-11	3689	5914	40	3739	5964	90	3789	6014
-60	3640	5865	-10	3690	5915	41	3740	5965	91	3790	6015
-59	3641	5866	-9	3691	5916	42	3741	5966	92	3791	6016
-58	3642	5867	-8	3692	5917	43	3742	5967	93	3792	6017
-57	3643	5868	-7	3693	5918	44	3743	5968	94	3793	6018
-56	3644	5869	-6	3694	5919	45	3744	5969	95	3794	6019
-55	3645	5870	-5	3695	5920	46	3745	5970	96	3795	6020
-54	3646	5871	-4	3696	5921	47	3746	5971	97	3796	6021
-53	3647	5872	-3	3697	5922	48	3747	5972	98	3797	6022
-52	3648	5873	-2	3698	5923	49	3748	5973	99	3798	6023
-51	3649	5874	-1	3699	5924	50	3749	5974	100	3799	6024
-50	3650	5875	1	3700	5925	51	3750	5975	101	3800	6025
-49	3651	5876	2	3701	5926	52	3751	5976	102	3801	6026
-48	3652	5877	3	3702	5927	53	3752	5977	103	3802	6027
-47	3653	5878	4	3703	5928	54	3753	5978	104	3803	6028
-46	3654	5879	5	3704	5929	55	3754	5979	105	3804	6029
-45	3655	5880	6	3705	5930	56	3755	5980	106	3805	6030
-44	3656	5881	7	3706	5931	57	3756	5981	107	3806	6031
-43	3657	5882	8	3707	5932	58	3757	5982	108	3807	6032
-42	3658	5883	9	3708	5933	59	3758	5983	109	3808	6033
-41	3659	5884	10	3709	5934	60	3759	5984	110	3809	6034
-40	3660	5885	11	3710	5935	61	3760	5985	111	3810	6035
-39	3661	5886	12	3711	5936	62	3761	5986	112	3811	6036
-38	3662	5887	13	3712	5937	63	3762	5987	113	3812	6037
-37	3663	5888	14	3713	5938	64	3763	5988	114	3813	6038
-36	3664	5889	15	3714	5939	65	3764	5989	115	3814	6039
-35	3665	5890	16	3715	5940	66	3765	5990	116	3815	6040
-34	3666	5891	17	3716	5941	67	3766	5991	117	3816	6041
-33	3667	5892	18	3717	5942	68	3767	5992	118	3817	6042
-32	3668	5893	19	3718	5943	69	3768	5993	119	3818	6043
-31	3669	5894	20	3719	5944	70	3769	5994	120	3819	6044
-30	3670	5895	21	3720	5945	71	3770	5995	121	3820	6045
-29	3671	5896	22	3721	5946	72	3771	5996	122	3821	6046
-28	3672	5897	23	3722	5947	73	3772	5997	123	3822	6047
-27	3673	5898	24	3723	5948	74	3773	5998	124	3823	6048
-26	3674	5899	25	3724	5949	75	3774	5999	125	3824	6049

ANASAT[®]-SEC Satellite Channels

Ch.	RX MHz	TX MHz	Ch.	RX MHz	TX MHz	Ch.	RX MHz	TX MHz	Ch.	RX MHz	TX MHz
126	3825	6050	176	3875	6100	226	3925	6150	276	3975	6200
127	3826	6051	177	3876	6101	227	3926	6151	277	3976	6201
128	3827	6052	178	3877	6102	228	3927	6152	278	3977	6202
129	3828	6053	179	3878	6103	229	3928	6153	279	3978	6203
130	3829	6054	180	3879	6104	230	3929	6154	280	3979	6204
131	3830	6055	181	3880	6105	231	3930	6155	281	3980	6205
132	3831	6056	182	3881	6106	232	3931	6156	282	3981	6206
133	3832	6057	183	3882	6107	233	3932	6157	283	3982	6207
134	3833	6058	184	3883	6108	234	3933	6158	284	3983	6208
135	3834	6059	185	3884	6109	235	3934	6159	285	3984	6209
136	3835	6060	186	3885	6110	236	3935	6160	286	3985	6210
137	3836	6061	187	3886	6111	237	3936	6161	287	3986	6211
138	3837	6062	188	3887	6112	238	3937	6162	288	3987	6212
139	3838	6063	189	3888	6113	239	3938	6163	289	3988	6213
140	3839	6064	190	3889	6114	240	3939	6164	290	3989	6214
141	3840	6065	191	3890	6115	241	3940	6165	291	3990	6215
142	3841	6066	192	3891	6116	242	3941	6166	292	3991	6216
143	3842	6067	193	3892	6117	243	3942	6167	293	3992	6217
144	3843	6068	194	3893	6118	244	3943	6168	294	3993	6218
145	3844	6069	195	3894	6119	245	3944	6169	295	3994	6219
146	3845	6070	196	3895	6120	246	3945	6170	296	3995	6220
147	3846	6071	197	3896	6121	247	3946	6171	297	3996	6221
148	3847	6072	198	3897	6122	248	3947	6172	298	3997	6222
149	3848	6073	199	3898	6123	249	3948	6173	299	3998	6223
150	3849	6074	200	3899	6124	250	3949	6174	300	3999	6224
151	3850	6075	201	3900	6125	251	3950	6175	301	4000	6225
152	3851	6076	202	3901	6126	252	3951	6176	302	4001	6226
153	3852	6077	203	3902	6127	253	3952	6177	303	4002	6227
154	3853	6078	204	3903	6128	254	3953	6178	304	4003	6228
155	3854	6079	205	3904	6129	255	3954	6179	305	4004	6229
156	3855	6080	206	3905	6130	256	3955	6180	306	4005	6230
157	3856	6081	207	3906	6131	257	3956	6181	307	4006	6231
158	3857	6082	208	3907	6132	258	3957	6182	308	4007	6232
159	3858	6083	209	3908	6133	259	3958	6183	309	4008	6233
160	3859	6084	210	3909	6134	260	3959	6184	310	4009	6234
161	3860	6085	211	3910	6135	261	3960	6185	311	4010	6235
162	3861	6086	212	3911	6136	262	3961	6186	312	4011	6236
163	3862	6087	213	3912	6137	263	3962	6187	313	4012	6237
164	3863	6088	214	3913	6138	264	3963	6188	314	4013	6238
165	3864	6089	215	3914	6139	265	3964	6189	315	4014	6239
166	3865	6090	216	3915	6140	266	3965	6190	316	4015	6240
167	3866	6091	217	3916	6141	267	3966	6191	317	4016	6241
168	3867	6092	218	3917	6142	268	3967	6192	318	4017	6242
169	3868	6093	219	3918	6143	269	3968	6193	319	4018	6243
170	3869	6094	220	3919	6144	270	3969	6194	320	4019	6244
171	3870	6095	221	3920	6145	271	3970	6195	321	4020	6245
172	3871	6096	222	3921	6146	272	3971	6196	322	4021	6246
173	3872	6097	223	3922	6147	273	3972	6197	323	4022	6247
174	3873	6098	224	3923	6148	274	3973	6198	324	4023	6248
175	3874	6099	225	3924	6149	275	3974	6199	325	4024	6249

ANASAT®-SEC Satellite Channels

Ch.	RX MHz	TX MHz	Ch.	RX MHz	TX MHz	Ch.	RX MHz	TX MHz	Ch.	RX MHz	TX MHz
326	4025	6250	376	4075	6300	426	4125	6350	476	4175	6400
327	4026	6251	377	4076	6301	427	4126	6351	477	4176	6401
328	4027	6252	378	4077	6302	428	4127	6352	478	4177	6402
329	4028	6253	379	4078	6303	429	4128	6353	479	4178	6403
330	4029	6254	380	4079	6304	430	4129	6354	480	4179	6404
331	4030	6255	381	4080	6305	431	4130	6355	481	4180	6405
332	4031	6256	382	4081	6306	432	4131	6356	482	4181	6406
333	4032	6257	383	4082	6307	433	4132	6357	483	4182	6407
334	4033	6258	384	4083	6308	434	4133	6358	484	4183	6408
335	4034	6259	385	4084	6309	435	4134	6359	485	4184	6409
336	4035	6260	386	4085	6310	436	4135	6360	486	4185	6410
337	4036	6261	387	4086	6311	437	4136	6361	487	4186	6411
338	4037	6262	388	4087	6312	438	4137	6362	488	4187	6412
339	4038	6263	389	4088	6313	439	4138	6363	489	4188	6413
340	4039	6264	390	4089	6314	440	4139	6364	490	4189	6414
341	4040	6265	391	4090	6315	441	4140	6365	491	4190	6415
342	4041	6266	392	4091	6316	442	4141	6366	492	4191	6416
343	4042	6267	393	4092	6317	443	4142	6367	493	4192	6417
344	4043	6268	394	4093	6318	444	4143	6368	494	4193	6418
345	4044	6269	395	4094	6319	445	4144	6369	495	4194	6419
346	4045	6270	396	4095	6320	446	4145	6370	496	4195	6420
347	4046	6271	397	4096	6321	447	4146	6371	497	4196	6421
348	4047	6272	398	4097	6322	448	4147	6372	498	4197	6422
349	4048	6273	399	4098	6323	449	4148	6373	499	4198	6423
350	4049	6274	400	4099	6324	450	4149	6374	500	4199	6424
351	4050	6275	401	4100	6325	451	4150	6375	501	4200	6425
352	4051	6276	402	4101	6326	452	4151	6376			
353	4052	6277	403	4102	6327	453	4152	6377			
354	4053	6278	404	4103	6328	454	4153	6378			
355	4054	6279	405	4104	6329	455	4154	6379			
356	4055	6280	406	4105	6330	456	4155	6380			
357	4056	6281	407	4106	6331	457	4156	6381			
358	4057	6282	408	4107	6332	458	4157	6382			
359	4058	6283	409	4108	6333	459	4158	6383			
360	4059	6284	410	4109	6334	460	4159	6384			
361	4060	6285	411	4110	6335	461	4160	6385			
362	4061	6286	412	4111	6336	462	4161	6386			
363	4062	6287	413	4112	6337	463	4162	6387			
364	4063	6288	414	4113	6338	464	4163	6388			
365	4064	6289	415	4114	6339	465	4164	6389			
366	4065	6290	416	4115	6340	466	4165	6390			
367	4066	6291	417	4116	6341	467	4166	6391			
368	4067	6292	418	4117	6342	468	4167	6392			
369	4068	6293	419	4118	6343	469	4168	6393			
370	4069	6294	420	4119	6344	470	4169	6394			
371	4070	6295	421	4120	6345	471	4170	6395			
372	4071	6296	422	4121	6346	472	4171	6396			
373	4072	6297	423	4122	6347	473	4172	6397			
374	4073	6298	424	4123	6348	474	4173	6398			
375	4074	6299	425	4124	6349	475	4174	6399			

...up to 6725 GHz

ANASAT®-XC Satellite Channels

Ch.	RX MHz	TX MHz	Ch.	RX MHz	TX MHz	Ch.	RX MHz	TX MHz	Ch.	RX MHz	TX MHz
1	4500	6725	51	4525	6750	101	4550	6775	151	4575	6800
2	4500.5	6725.5	52	4525.5	6750.5	102	4550.5	6775.5	152	4575.5	6800.5
3	4501	6726	53	4526	6751	103	4551	6776	153	4576	6801
4	4501.5	6726.5	54	4526.5	6751.5	104	4551.5	6776.5	154	4576.5	6801.5
5	4502	6727	55	4527	6752	105	4552	6777	155	4577	6802
6	4502.5	6727.5	56	4527.5	6752.5	106	4552.5	6777.5	156	4577.5	6802.5
7	4503	6728	57	4528	6753	107	4553	6778	157	4578	6803
8	4503.5	6728.5	58	4528.5	6753.5	108	4553.5	6778.5	158	4578.5	6803.5
9	4504	6729	59	4529	6754	109	4554	6779	159	4579	6804
10	4504.5	6729.5	60	4529.5	6754.5	110	4554.5	6779.5	160	4579.5	6804.5
11	4505	6730	61	4530	6755	111	4555	6780	161	4580	6805
12	4505.5	6730.5	62	4530.5	6755.5	112	4555.5	6780.5	162	4580.5	6805.5
13	4506	6731	63	4531	6756	113	4556	6781	163	4581	6806
14	4506.5	6731.5	64	4531.5	6756.5	114	4556.5	6781.5	164	4581.5	6806.5
15	4507	6732	65	4532	6757	115	4557	6782	165	4582	6807
16	4507.5	6732.5	66	4532.5	6757.5	116	4557.5	6782.5	166	4582.5	6807.5
17	4508	6733	67	4533	6758	117	4558	6783	167	4583	6808
18	4508.5	6733.5	68	4533.5	6758.5	118	4558.5	6783.5	168	4583.5	6808.5
19	4509	6734	69	4534	6759	119	4559	6784	169	4584	6809
20	4509.5	6734.5	70	4534.5	6759.5	120	4559.5	6784.5	170	4584.5	6809.5
21	4510	6735	71	4535	6760	121	4560	6785	171	4585	6810
22	4510.5	6735.5	72	4535.5	6760.5	122	4560.5	6785.5	172	4585.5	6810.5
23	4511	6736	73	4536	6761	123	4561	6786	173	4586	6811
24	4511.5	6736.5	74	4536.5	6761.5	124	4561.5	6786.5	174	4586.5	6811.5
25	4512	6737	75	4537	6762	125	4562	6787	175	4587	6812
26	4512.5	6737.5	76	4537.5	6762.5	126	4562.5	6787.5	176	4587.5	6812.5
27	4513	6738	77	4538	6763	127	4563	6788	177	4588	6813
28	4513.5	6738.5	78	4538.5	6763.5	128	4563.5	6788.5	178	4588.5	6813.5
29	4514	6739	79	4539	6764	129	4564	6789	179	4589	6814
30	4514.5	6739.5	80	4539.5	6764.5	130	4564.5	6789.5	180	4589.5	6814.5
31	4515	6740	81	4540	6765	131	4565	6790	181	4590	6815
32	4515.5	6740.5	82	4540.5	6765.5	132	4565.5	6790.5	182	4590.5	6815.5
33	4516	6741	83	4541	6766	133	4566	6791	183	4591	6816
34	4516.5	6741.5	84	4541.5	6766.5	134	4566.5	6791.5	184	4591.5	6816.5
35	4517	6742	85	4542	6767	135	4567	6792	185	4592	6817
36	4517.5	6742.5	86	4542.5	6767.5	136	4567.5	6792.5	186	4592.5	6817.5
37	4518	6743	87	4543	6768	137	4568	6793	187	4593	6818
38	4518.5	6743.5	88	4543.5	6768.5	138	4568.5	6793.5	188	4593.5	6818.5
39	4519	6744	89	4544	6769	139	4569	6794	189	4594	6819
40	4519.5	6744.5	90	4544.5	6769.5	140	4569.5	6794.5	190	4594.5	6819.5
41	4520	6745	91	4545	6770	141	4570	6795	191	4595	6820
42	4520.5	6745.5	92	4545.5	6770.5	142	4570.5	6795.5	192	4595.5	6820.5
43	4521	6746	93	4546	6771	143	4571	6796	193	4596	6821
44	4521.5	6746.5	94	4546.5	6771.5	144	4571.5	6796.5	194	4596.5	6821.5
45	4522	6747	95	4547	6772	145	4572	6797	195	4597	6822
46	4522.5	6747.5	96	4547.5	6772.5	146	4572.5	6797.5	196	4597.5	6822.5
47	4523	6748	97	4548	6773	147	4573	6798	197	4598	6823
48	4523.5	6748.5	98	4548.5	6773.5	148	4573.5	6798.5	198	4598.5	6823.5
49	4524	6749	99	4549	6774	149	4574	6799	199	4599	6824
50	4524.5	6749.5	100	4549.5	6774.5	150	4574.5	6799.5	200	4599.5	6824.5

ANASAT®-XC Satellite Channels

Ch.	RX MHz	TX MHz	Ch.	RX MHz	TX MHz	Ch.	RX MHz	TX MHz	Ch.	RX MHz	TX MHz
201	4600	6825	251	4625	6850	301	4650	6875	351	4675	6900
202	4600.5	6825.5	252	4625.5	6850.5	302	4650.5	6875.5	352	4675.5	6900.5
203	4601	6826	253	4626	6851	303	4651	6876	353	4676	6901
204	4601.5	6826.5	254	4626.5	6851.5	304	4651.5	6876.5	354	4676.5	6901.5
205	4602	6827	255	4627	6852	305	4652	6877	355	4677	6902
206	4602.5	6827.5	256	4627.5	6852.5	306	4652.5	6877.5	356	4677.5	6902.5
207	4603	6828	257	4628	6853	307	4653	6878	357	4678	6903
208	4603.5	6828.5	258	4628.5	6853.5	308	4653.5	6878.5	358	4678.5	6903.5
209	4604	6829	259	4629	6854	309	4654	6879	359	4679	6904
210	4604.5	6829.5	260	4629.5	6854.5	310	4654.5	6879.5	360	4679.5	6904.5
211	4605	6830	261	4630	6855	311	4655	6880	361	4680	6905
212	4605.5	6830.5	262	4630.5	6855.5	312	4655.5	6880.5	362	4680.5	6905.5
213	4606	6831	263	4631	6856	313	4656	6881	363	4681	6906
214	4606.5	6831.5	264	4631.5	6856.5	314	4656.5	6881.5	364	4681.5	6906.5
215	4607	6832	265	4632	6857	315	4657	6882	365	4682	6907
216	4607.5	6832.5	266	4632.5	6857.5	316	4657.5	6882.5	366	4682.5	6907.5
217	4608	6833	267	4633	6858	317	4658	6883	367	4683	6908
218	4608.5	6833.5	268	4633.5	6858.5	318	4658.5	6883.5	368	4683.5	6908.5
219	4609	6834	269	4634	6859	319	4659	6884	369	4684	6909
220	4609.5	6834.5	270	4634.5	6859.5	320	4659.5	6884.5	370	4684.5	6909.5
221	4610	6835	271	4635	6860	321	4660	6885	371	4685	6910
222	4610.5	6835.5	272	4635.5	6860.5	322	4660.5	6885.5	372	4685.5	6910.5
223	4611	6836	273	4636	6861	323	4661	6886	373	4686	6911
224	4611.5	6836.5	274	4636.5	6861.5	324	4661.5	6886.5	374	4686.5	6911.5
225	4612	6837	275	4637	6862	325	4662	6887	375	4687	6912
226	4612.5	6837.5	276	4637.5	6862.5	326	4662.5	6887.5	376	4687.5	6912.5
227	4613	6838	277	4638	6863	327	4663	6888	377	4688	6913
228	4613.5	6838.5	278	4638.5	6863.5	328	4663.5	6888.5	378	4688.5	6913.5
229	4614	6839	279	4639	6864	329	4664	6889	379	4689	6914
230	4614.5	6839.5	280	4639.5	6864.5	330	4664.5	6889.5	380	4689.5	6914.5
231	4615	6840	281	4640	6865	331	4665	6890	381	4690	6915
232	4615.5	6840.5	282	4640.5	6865.5	332	4665.5	6890.5	382	4690.5	6915.5
233	4616	6841	283	4641	6866	333	4666	6891	383	4691	6916
234	4616.5	6841.5	284	4641.5	6866.5	334	4666.5	6891.5	384	4691.5	6916.5
235	4617	6842	285	4642	6867	335	4667	6892	385	4692	6917
236	4617.5	6842.5	286	4642.5	6867.5	336	4667.5	6892.5	386	4692.5	6917.5
237	4618	6843	287	4643	6868	337	4668	6893	387	4693	6918
238	4618.5	6843.5	288	4643.5	6868.5	338	4668.5	6893.5	388	4693.5	6918.5
239	4619	6844	289	4644	6869	339	4669	6894	389	4694	6919
240	4619.5	6844.5	290	4644.5	6869.5	340	4669.5	6894.5	390	4694.5	6919.5
241	4620	6845	291	4645	6870	341	4670	6895	391	4695	6920
242	4620.5	6845.5	292	4645.5	6870.5	342	4670.5	6895.5	392	4695.5	6920.5
243	4621	6846	293	4646	6871	343	4671	6896	393	4696	6921
244	4621.5	6846.5	294	4646.5	6871.5	344	4671.5	6896.5	394	4696.5	6921.5
245	4622	6847	295	4647	6872	345	4672	6897	395	4697	6922
246	4622.5	6847.5	296	4647.5	6872.5	346	4672.5	6897.5	396	4697.5	6922.5
247	4623	6848	297	4648	6873	347	4673	6898	397	4698	6923
248	4623.5	6848.5	298	4648.5	6873.5	348	4673.5	6898.5	398	4698.5	6923.5
249	4624	6849	299	4649	6874	349	4674	6899	399	4699	6924
250	4624.5	6849.5	300	4649.5	6874.5	350	4674.5	6899.5	400	4699.5	6924.5

ANASAT[®]-XC Satellite Channels

Ch.	RX MHz	TX MHz	Ch.	RX MHz	TX MHz	Ch.	RX MHz	TX MHz	Ch.	RX MHz	TX MHz
401	4700	6925	451	4725	6950	501	4750	6975	551	4775	7000
402	4700.5	6925.5	452	4725.5	6950.5	502	4750.5	6975.5	552	4775.5	7000.5
403	4701	6926	453	4726	6951	503	4751	6976	553	4776	7001
404	4701.5	6926.5	454	4726.5	6951.5	504	4751.5	6976.5	554	4776.5	7001.5
405	4702	6927	455	4727	6952	505	4752	6977	555	4777	7002
406	4702.5	6927.5	456	4727.5	6952.5	506	4752.5	6977.5	556	4777.5	7002.5
407	4703	6928	457	4728	6953	507	4753	6978	557	4778	7003
408	4703.5	6928.5	458	4728.5	6953.5	508	4753.5	6978.5	558	4778.5	7003.5
409	4704	6929	459	4729	6954	509	4754	6979	559	4779	7004
410	4704.5	6929.5	460	4729.5	6954.5	510	4754.5	6979.5	560	4779.5	7004.5
411	4705	6930	461	4730	6955	511	4755	6980	561	4780	7005
412	4705.5	6930.5	462	4730.5	6955.5	512	4755.5	6980.5	562	4780.5	7005.5
413	4706	6931	463	4731	6956	513	4756	6981	563	4781	7006
414	4706.5	6931.5	464	4731.5	6956.5	514	4756.5	6981.5	564	4781.5	7006.5
415	4707	6932	465	4732	6957	515	4757	6982	565	4782	7007
416	4707.5	6932.5	466	4732.5	6957.5	516	4757.5	6982.5	566	4782.5	7007.5
417	4708	6933	467	4733	6958	517	4758	6983	567	4783	7008
418	4708.5	6933.5	468	4733.5	6958.5	518	4758.5	6983.5	568	4783.5	7008.5
419	4709	6934	469	4734	6959	519	4759	6984	569	4784	7009
420	4709.5	6934.5	470	4734.5	6959.5	520	4759.5	6984.5	570	4784.5	7009.5
421	4710	6935	471	4735	6960	521	4760	6985	571	4785	7010
422	4710.5	6935.5	472	4735.5	6960.5	522	4760.5	6985.5	572	4785.5	7010.5
423	4711	6936	473	4736	6961	523	4761	6986	573	4786	7011
424	4711.5	6936.5	474	4736.5	6961.5	524	4761.5	6986.5	574	4786.5	7011.5
425	4712	6937	475	4737	6962	525	4762	6987	575	4787	7012
426	4712.5	6937.5	476	4737.5	6962.5	526	4762.5	6987.5	576	4787.5	7012.5
427	4713	6938	477	4738	6963	527	4763	6988	577	4788	7013
428	4713.5	6938.5	478	4738.5	6963.5	528	4763.5	6988.5	578	4788.5	7013.5
429	4714	6939	479	4739	6964	529	4764	6989	579	4789	7014
430	4714.5	6939.5	480	4739.5	6964.5	530	4764.5	6989.5	580	4789.5	7014.5
431	4715	6940	481	4740	6965	531	4765	6990	581	4790	7015
432	4715.5	6940.5	482	4740.5	6965.5	532	4765.5	6990.5	582	4790.5	7015.5
433	4716	6941	483	4741	6966	533	4766	6991	583	4791	7016
434	4716.5	6941.5	484	4741.5	6966.5	534	4766.5	6991.5	584	4791.5	7016.5
435	4717	6942	485	4742	6967	535	4767	6992	585	4792	7017
436	4717.5	6942.5	486	4742.5	6967.5	536	4767.5	6992.5	586	4792.5	7017.5
437	4718	6943	487	4743	6968	537	4768	6993	587	4793	7018
438	4718.5	6943.5	488	4743.5	6968.5	538	4768.5	6993.5	588	4793.5	7018.5
439	4719	6944	489	4744	6969	539	4769	6994	589	4794	7019
440	4719.5	6944.5	490	4744.5	6969.5	540	4769.5	6994.5	590	4794.5	7019.5
441	4720	6945	491	4745	6970	541	4770	6995	591	4795	7020
442	4720.5	6945.5	492	4745.5	6970.5	542	4770.5	6995.5	592	4795.5	7020.5
443	4721	6946	493	4746	6971	543	4771	6996	593	4796	7021
444	4721.5	6946.5	494	4746.5	6971.5	544	4771.5	6996.5	594	4796.5	7021.5
445	4722	6947	495	4747	6972	545	4772	6997	595	4797	7022
446	4722.5	6947.5	496	4747.5	6972.5	546	4772.5	6997.5	596	4797.5	7022.5
447	4723	6948	497	4748	6973	547	4773	6998	597	4798	7023
448	4723.5	6948.5	498	4748.5	6973.5	548	4773.5	6998.5	598	4798.5	7023.5
449	4724	6949	499	4749	6974	549	4774	6999	599	4799	7024
450	4724.5	6949.5	500	4749.5	6974.5	550	4774.5	6999.5	600	4799.5	7024.5
									601	4800	7025.0

ANASAT®-PC Satellite Channels

Ch.	RX MHz	TX MHz	Ch.	RX MHz	TX MHz	Ch.	RX MHz	TX MHz	Ch.	RX MHz	TX MHz
1	3400	6425	51	3450	6475	101	3500	6525	151	3550	6575
2	3401	6426	52	3451	6476	102	3501	6526	152	3551	6576
3	3402	6427	53	3452	6477	103	3502	6527	153	3552	6577
4	3403	6428	54	3453	6478	104	3503	6528	154	3553	6578
5	3404	6429	55	3454	6479	105	3504	6529	155	3554	6579
6	3405	6430	56	3455	6480	106	3505	6530	156	3555	6580
7	3406	6431	57	3456	6481	107	3506	6531	157	3556	6581
8	3407	6432	58	3457	6482	108	3507	6532	158	3557	6582
9	3408	6433	59	3458	6483	109	3508	6533	159	3558	6583
10	3409	6434	60	3459	6484	110	3509	6534	160	3559	6584
11	3410	6435	61	3460	6485	111	3510	6535	161	3560	6585
12	3411	6436	62	3461	6486	112	3511	6536	162	3561	6586
13	3412	6437	63	3462	6487	113	3512	6537	163	3562	6587
14	3413	6438	64	3463	6488	114	3513	6538	164	3563	6588
15	3414	6439	65	3464	6489	115	3514	6539	165	3564	6589
16	3415	6440	66	3465	6490	116	3515	6540	166	3565	6590
17	3416	6441	67	3466	6491	117	3516	6541	167	3566	6591
18	3417	6442	68	3467	6492	118	3517	6542	168	3567	6592
19	3418	6443	69	3468	6493	119	3518	6543	169	3568	6593
20	3419	6444	70	3469	6494	120	3519	6544	170	3569	6594
21	3420	6445	71	3470	6495	121	3520	6545	171	3570	6595
22	3421	6446	72	3471	6496	122	3521	6546	172	3571	6596
23	3422	6447	73	3472	6497	123	3522	6547	173	3572	6597
24	3423	6448	74	3473	6498	124	3523	6548	174	3573	6598
25	3424	6449	75	3474	6499	125	3524	6549	175	3574	6599
26	3425	6450	76	3475	6500	126	3525	6550	176	3575	6600
27	3426	6451	77	3476	6501	127	3526	6551	177	3576	6601
28	3427	6452	78	3477	6502	128	3527	6552	178	3577	6602
29	3428	6453	79	3478	6503	129	3528	6553	179	3578	6603
30	3429	6454	80	3479	6504	130	3529	6554	180	3579	6604
31	3430	6455	81	3480	6505	131	3530	6555	181	3580	6605
32	3431	6456	82	3481	6506	132	3531	6556	182	3581	6606
33	3432	6457	83	3482	6507	133	3532	6557	183	3582	6607
34	3433	6458	84	3483	6508	134	3533	6558	184	3583	6608
35	3434	6459	85	3484	6509	135	3534	6559	185	3584	6609
36	3435	6460	86	3485	6510	136	3535	6560	186	3585	6610
37	3436	6461	87	3486	6511	137	3536	6561	187	3586	6611
38	3437	6462	88	3487	6512	138	3537	6562	188	3587	6612
39	3438	6463	89	3488	6513	139	3538	6563	189	3588	6613
40	3439	6464	90	3489	6514	140	3539	6564	190	3589	6614
41	3440	6465	91	3490	6515	141	3540	6565	191	3590	6615
42	3441	6466	92	3491	6516	142	3541	6566	192	3591	6616
43	3442	6467	93	3492	6517	143	3542	6567	193	3592	6617
44	3443	6468	94	3493	6518	144	3543	6568	194	3593	6618
45	3444	6469	95	3494	6519	145	3544	6569	195	3594	6619
46	3445	6470	96	3495	6520	146	3545	6570	196	3595	6620
47	3446	6471	97	3496	6521	147	3546	6571	197	3596	6621
48	3447	6472	98	3497	6522	148	3547	6572	198	3597	6622
49	3448	6473	99	3498	6523	149	3548	6573	199	3598	6623
50	3449	6474	100	3499	6524	150	3549	6574	200	3599	6624

ANASAT[®]-PC Satellite Channels

Ch.	RX MHz	TX MHz	Ch.	RX MHz	TX MHz	Ch.	RX MHz	TX MHz
201	3600	6625	251	3650	6675	301	3700	6725
202	3601	6626	252	3651	6676	302	3701	6726
203	3602	6627	253	3652	6677			
204	3603	6628	254	3653	6678			
205	3604	6629	255	3654	6679			
206	3605	6630	256	3655	6680			
207	3606	6631	257	3656	6681			
208	3607	6632	258	3657	6682			
209	3608	6633	259	3658	6683			
210	3609	6634	260	3659	6684			
211	3610	6635	261	3660	6685			
212	3611	6636	262	3661	6686			
213	3612	6637	263	3662	6687			
214	3613	6638	264	3663	6688			
215	3614	6639	265	3664	6689			
216	3615	6640	266	3665	6690			
217	3616	6641	267	3666	6691			
218	3617	6642	268	3667	6692			
219	3618	6643	269	3668	6693			
220	3619	6644	270	3669	6694			
221	3620	6645	271	3670	6695			
222	3621	6646	272	3671	6696			
223	3622	6647	273	3672	6697			
224	3623	6648	274	3673	6698			
225	3624	6649	275	3674	6699			
226	3625	6650	276	3675	6700			
227	3626	6651	277	3676	6701			
228	3627	6652	278	3677	6702			
229	3628	6653	279	3678	6703			
230	3629	6654	280	3679	6704			
231	3630	6655	281	3680	6705			
232	3631	6656	282	3681	6706			
233	3632	6657	283	3682	6707			
234	3633	6658	284	3683	6708			
235	3634	6659	285	3684	6709			
236	3635	6660	286	3685	6710			
237	3636	6661	287	3686	6711			
238	3637	6662	288	3687	6712			
239	3638	6663	289	3688	6713			
240	3639	6664	290	3689	6714			
241	3640	6665	291	3690	6715			
242	3641	6666	292	3691	6716			
243	3642	6667	293	3692	6717			
244	3643	6668	294	3693	6718			
245	3644	6669	295	3694	6719			
246	3645	6670	296	3695	6720			
247	3646	6671	297	3696	6721			
248	3647	6672	298	3697	6722			
249	3648	6673	299	3698	6723			
250	3649	6674	300	3699	6724			

ANASAT[®]-RC Satellite Channels

Ch.	RX MHz	TX MHz	Ch.	RX MHz	TX MHz	Ch.	RX MHz	TX MHz	Ch.	RX MHz	TX MHz
1	3650	5975	51	3700	6025	101	3750	6075	151	3800	6125
2	3651	5976	52	3701	6026	102	3751	6076	152	3801	6126
3	3652	5977	53	3702	6027	103	3752	6077	153	3802	6127
4	3653	5978	54	3703	6028	104	3753	6078	154	3803	6128
5	3654	5979	55	3704	6029	105	3754	6079	155	3804	6129
6	3655	5980	56	3705	6030	106	3755	6080	156	3805	6130
7	3656	5981	57	3706	6031	107	3756	6081	157	3806	6131
8	3657	5982	58	3707	6032	108	3757	6082	158	3807	6132
9	3658	5983	59	3708	6033	109	3758	6083	159	3808	6133
10	3659	5984	60	3709	6034	110	3759	6084	160	3809	6134
11	3660	5985	61	3710	6035	111	3760	6085	161	3810	6135
12	3661	5986	62	3711	6036	112	3761	6086	162	3811	6136
13	3662	5987	63	3712	6037	113	3762	6087	163	3812	6137
14	3663	5988	64	3713	6038	114	3763	6088	164	3813	6138
15	3664	5989	65	3714	6039	115	3764	6089	165	3814	6139
16	3665	5990	66	3715	6040	116	3765	6090	166	3815	6140
17	3666	5991	67	3716	6041	117	3766	6091	167	3816	6141
18	3667	5992	68	3717	6042	118	3767	6092	168	3817	6142
19	3668	5993	69	3718	6043	119	3768	6093	169	3818	6143
20	3669	5994	70	3719	6044	120	3769	6094	170	3819	6144
21	3670	5995	71	3720	6045	121	3770	6095	171	3820	6145
22	3671	5996	72	3721	6046	122	3771	6096	172	3821	6146
23	3672	5997	73	3722	6047	123	3772	6097	173	3822	6147
24	3673	5998	74	3723	6048	124	3773	6098	174	3823	6148
25	3674	5999	75	3724	6049	125	3774	6099	175	3824	6149
26	3675	6000	76	3725	6050	126	3775	6100	176	3825	6150
27	3676	6001	77	3726	6051	127	3776	6101	177	3826	6151
28	3677	6002	78	3727	6052	128	3777	6102	178	3827	6152
29	3678	6003	79	3728	6053	129	3778	6103	179	3828	6153
30	3679	6004	80	3729	6054	130	3779	6104	180	3829	6154
31	3680	6005	81	3730	6055	131	3780	6105	181	3830	6155
32	3681	6006	82	3731	6056	132	3781	6106	182	3831	6156
33	3682	6007	83	3732	6057	133	3782	6107	183	3832	6157
34	3683	6008	84	3733	6058	134	3783	6108	184	3833	6158
35	3684	6009	85	3734	6059	135	3784	6109	185	3834	6159
36	3685	6010	86	3735	6060	136	3785	6110	186	3835	6160
37	3686	6011	87	3736	6061	137	3786	6111	187	3836	6161
38	3687	6012	88	3737	6062	138	3787	6112	188	3837	6162
39	3688	6013	89	3738	6063	139	3788	6113	189	3838	6163
40	3689	6014	90	3739	6064	140	3789	6114	190	3839	6164
41	3690	6015	91	3740	6065	141	3790	6115	191	3840	6165
42	3691	6016	92	3741	6066	142	3791	6116	192	3841	6166
43	3692	6017	93	3742	6067	143	3792	6117	193	3842	6167
44	3693	6018	94	3743	6068	144	3793	6118	194	3843	6168
45	3694	6019	95	3744	6069	145	3794	6119	195	3844	6169
46	3695	6020	96	3745	6070	146	3795	6120	196	3845	6170
47	3696	6021	97	3746	6071	147	3796	6121	197	3846	6171
48	3697	6022	98	3747	6072	148	3797	6122	198	3847	6172
49	3698	6023	99	3748	6073	149	3798	6123	199	3848	6173
50	3699	6024	100	3749	6074	150	3799	6124	200	3849	6174

ANASAT[®]-RC Satellite Channels

Ch.	RX MHz	TX MHz	Ch.	RX MHz	TX MHz	Ch.	RX MHz	TX MHz	Ch.	RX MHz	TX MHz
201	3850	6175	251	3900	6225	301	3950	6275	351	4000	6325
202	3851	6176	252	3901	6226	302	3951	6276	352	4001	6326
203	3852	6177	253	3902	6227	303	3952	6277	353	4002	6327
204	3853	6178	254	3903	6228	304	3953	6278	354	4003	6328
205	3854	6179	255	3904	6229	305	3954	6279	355	4004	6329
206	3855	6180	256	3905	6230	306	3955	6280	356	4005	6330
207	3856	6181	257	3906	6231	307	3956	6281	357	4006	6331
208	3857	6182	258	3907	6232	308	3957	6282	358	4007	6332
209	3858	6183	259	3908	6233	309	3958	6283	359	4008	6333
210	3859	6184	260	3909	6234	310	3959	6284	360	4009	6334
211	3860	6185	261	3910	6235	311	3960	6285	361	4010	6335
212	3861	6186	262	3911	6236	312	3961	6286	362	4011	6336
213	3862	6187	263	3912	6237	313	3962	6287	363	4012	6337
214	3863	6188	264	3913	6238	314	3963	6288	364	4013	6338
215	3864	6189	265	3914	6239	315	3964	6289	365	4014	6339
216	3865	6190	266	3915	6240	316	3965	6290	366	4015	6340
217	3866	6191	267	3916	6241	317	3966	6291	367	4016	6341
218	3867	6192	268	3917	6242	318	3967	6292	368	4017	6342
219	3868	6193	269	3918	6243	319	3968	6293	369	4018	6343
220	3869	6194	270	3919	6244	320	3969	6294	370	4019	6344
221	3870	6195	271	3920	6245	321	3970	6295	371	4020	6345
222	3871	6196	272	3921	6246	322	3971	6296	372	4021	6346
223	3872	6197	273	3922	6247	323	3972	6297	373	4022	6347
224	3873	6198	274	3923	6248	324	3973	6298	374	4023	6348
225	3874	6199	275	3924	6249	325	3974	6299	375	4024	6349
226	3875	6200	276	3925	6250	326	3975	6300	376	4025	6350
227	3876	6201	277	3926	6251	327	3976	6301	377	4026	6351
228	3877	6202	278	3927	6252	328	3977	6302	378	4027	6352
229	3878	6203	279	3928	6253	329	3978	6303	379	4028	6353
230	3879	6204	280	3929	6254	330	3979	6304	380	4029	6354
231	3880	6205	281	3930	6255	331	3980	6305	381	4030	6355
232	3881	6206	282	3931	6256	332	3981	6306	382	4031	6356
233	3882	6207	283	3932	6257	333	3982	6307	383	4032	6357
234	3883	6208	284	3933	6258	334	3983	6308	384	4033	6358
235	3884	6209	285	3934	6259	335	3984	6309	385	4034	6359
236	3885	6210	286	3935	6260	336	3985	6310	386	4035	6360
237	3886	6211	287	3936	6261	337	3986	6311	387	4036	6361
238	3887	6212	288	3937	6262	338	3987	6312	388	4037	6362
239	3888	6213	289	3938	6263	339	3988	6313	389	4038	6363
240	3889	6214	290	3939	6264	340	3989	6314	390	4039	6364
241	3890	6215	291	3940	6265	341	3990	6315	391	4040	6365
242	3891	6216	292	3941	6266	342	3991	6316	392	4041	6366
243	3892	6217	293	3942	6267	343	3992	6317	393	4042	6367
244	3893	6218	294	3943	6268	344	3993	6318	394	4043	6368
245	3894	6219	295	3944	6269	345	3994	6319	395	4044	6369
246	3895	6220	296	3945	6270	346	3995	6320	396	4045	6370
247	3896	6221	297	3946	6271	347	3996	6321	397	4046	6371
248	3897	6222	298	3947	6272	348	3997	6322	398	4047	6372
249	3898	6223	299	3948	6273	349	3998	6323	399	4048	6373
250	3899	6224	300	3949	6274	350	3999	6324	400	4049	6374

ANASAT[®]-RC Satellite Channels

Ch.	RX MHz	TX MHz	Ch.	RX MHz	TX MHz	Ch.	RX MHz	TX MHz
401	4050	6375	451	4100	6425	501	4150	6475
402	4051	6376	452	4101	6426			
403	4052	6377	453	4102	6427			
404	4053	6378	454	4103	6428			
405	4054	6379	455	4104	6429			
406	4055	6380	456	4105	6430			
407	4056	6381	457	4106	6431			
408	4057	6382	458	4107	6432			
409	4058	6383	459	4108	6433			
410	4059	6384	460	4109	6434			
411	4060	6385	461	4110	6435			
412	4061	6386	462	4111	6436			
413	4062	6387	463	4112	6437			
414	4063	6388	464	4113	6438			
415	4064	6389	465	4114	6439			
416	4065	6390	466	4115	6440			
417	4066	6391	467	4116	6441			
418	4067	6392	468	4117	6442			
419	4068	6393	469	4118	6443			
420	4069	6394	470	4119	6444			
421	4070	6395	471	4120	6445			
422	4071	6396	472	4121	6446			
423	4072	6397	473	4122	6447			
424	4073	6398	474	4123	6448			
425	4074	6399	475	4124	6449			
426	4075	6400	476	4125	6450			
427	4076	6401	477	4126	6451			
428	4077	6402	478	4127	6452			
429	4078	6403	479	4128	6453			
430	4079	6404	480	4129	6454			
431	4080	6405	481	4130	6455			
432	4081	6406	482	4131	6456			
433	4082	6407	483	4132	6457			
434	4083	6408	484	4133	6458			
435	4084	6409	485	4134	6459			
436	4085	6410	486	4135	6460			
437	4086	6411	487	4136	6461			
438	4087	6412	488	4137	6462			
439	4088	6413	489	4138	6463			
440	4089	6414	490	4139	6464			
441	4090	6415	491	4140	6465			
442	4091	6416	492	4141	6466			
443	4092	6417	493	4142	6467			
444	4093	6418	494	4143	6468			
445	4094	6419	495	4144	6469			
446	4095	6420	496	4145	6470			
447	4096	6421	497	4146	6471			
448	4097	6422	498	4147	6472			
449	4098	6423	499	4148	6473			
450	4099	6424	500	4149	6474			

ANASAT[®]-LMC Satellite Channels

Ch.	RX MHz	TX MHz	Ch.	RX MHz	TX MHz	Ch.	RX MHz	TX MHz	Ch.	RX MHz	TX MHz
-75	3375	5700	-25	3425	5750	26	3475	5800	76	3525	5850
-74	3376	5701	-24	3426	5751	27	3476	5801	77	3526	5851
-73	3377	5702	-23	3427	5752	28	3477	5802	78	3527	5852
-72	3378	5703	-22	3428	5753	29	3478	5803	79	3528	5853
-71	3379	5704	-21	3429	5754	30	3479	5804	80	3529	5854
-70	3380	5705	-20	3430	5755	31	3480	5805	81	3530	5855
-69	3381	5706	-19	3431	5756	32	3481	5806	82	3531	5856
-68	3382	5707	-18	3432	5757	33	3482	5807	83	3532	5857
-67	3383	5708	-17	3433	5758	34	3483	5808	84	3533	5858
-66	3384	5709	-16	3434	5759	35	3484	5809	85	3534	5859
-65	3385	5710	-15	3435	5760	36	3485	5810	86	3535	5860
-64	3386	5711	-14	3436	5761	37	3486	5811	87	3536	5861
-63	3387	5712	-13	3437	5762	38	3487	5812	88	3537	5862
-62	3388	5713	-12	3438	5763	39	3488	5813	89	3538	5863
-61	3389	5714	-11	3439	5764	40	3489	5814	90	3539	5864
-60	3390	5715	-10	3440	5765	41	3490	5815	91	3540	5865
-59	3391	5716	-9	3441	5766	42	3491	5816	92	3541	5866
-58	3392	5717	-8	3442	5767	43	3492	5817	93	3542	5867
-57	3393	5718	-7	3443	5768	44	3493	5818	94	3543	5868
-56	3394	5719	-6	3444	5769	45	3494	5819	95	3544	5869
-55	3395	5720	-5	3445	5770	46	3495	5820	96	3545	5870
-54	3396	5721	-4	3446	5771	47	3496	5821	97	3546	5871
-53	3397	5722	-3	3447	5772	48	3497	5822	98	3547	5872
-52	3398	5723	-2	3448	5773	49	3498	5823	99	3548	5873
-51	3399	5724	-1	3449	5774	50	3499	5824	100	3549	5874
-50	3400	5725	1	3450	5775	51	3500	5825	101	3550	5875
-49	3401	5726	2	3451	5776	52	3501	5826	102	3551	5876
-48	3402	5727	3	3452	5777	53	3502	5827	103	3552	5877
-47	3403	5728	4	3453	5778	54	3503	5828	104	3553	5878
-46	3404	5729	5	3454	5779	55	3504	5829	105	3554	5879
-45	3405	5730	6	3455	5780	56	3505	5830	106	3555	5880
-44	3406	5731	7	3456	5781	57	3506	5831	107	3556	5881
-43	3407	5732	8	3457	5782	58	3507	5832	108	3557	5882
-42	3408	5733	9	3458	5783	59	3508	5833	109	3558	5883
-41	3409	5734	10	3459	5784	60	3509	5834	110	3559	5884
-40	3410	5735	11	3460	5785	61	3510	5835	111	3560	5885
-39	3411	5736	12	3461	5786	62	3511	5836	112	3561	5886
-38	3412	5737	13	3462	5787	63	3512	5837	113	3562	5887
-37	3413	5738	14	3463	5788	64	3513	5838	114	3563	5888
-36	3414	5739	15	3464	5789	65	3514	5839	115	3564	5889
-35	3415	5740	16	3465	5790	66	3515	5840	116	3565	5890
-34	3416	5741	17	3466	5791	67	3516	5841	117	3566	5891
-33	3417	5742	18	3467	5792	68	3517	5842	118	3567	5892
-32	3418	5743	19	3468	5793	69	3518	5843	119	3568	5893
-31	3419	5744	20	3469	5794	70	3519	5844	120	3569	5894
-30	3420	5745	21	3470	5795	71	3520	5845	121	3570	5895
-29	3421	5746	22	3471	5796	72	3521	5846	122	3571	5896
-28	3422	5747	23	3472	5797	73	3522	5847	123	3572	5897
-27	3423	5748	24	3473	5798	74	3523	5848	124	3573	5898
-26	3424	5749	25	3474	5799	75	3524	5849	125	3574	5899

ANASAT®-LMC Satellite Channels

Ch.	RX MHz	TX MHz	Ch.	RX MHz	TX MHz	Ch.	RX MHz	TX MHz	Ch.	RX MHz	TX MHz
126	3575	5900	176	3625	5950	226	3675	6000	276	3725	6050
127	3576	5901	177	3626	5951	227	3676	6001	277	3726	6051
128	3577	5902	178	3627	5952	228	3677	6002	278	3727	6052
129	3578	5903	179	3628	5953	229	3678	6003	279	3728	6053
130	3579	5904	180	3629	5954	230	3679	6004	280	3729	6054
131	3580	5905	181	3630	5955	231	3680	6005	281	3730	6055
132	3581	5906	182	3631	5956	232	3681	6006	282	3731	6056
133	3582	5907	183	3632	5957	233	3682	6007	283	3732	6057
134	3583	5908	184	3633	5958	234	3683	6008	284	3733	6058
135	3584	5909	185	3634	5959	235	3684	6009	285	3734	6059
136	3585	5910	186	3635	5960	236	3685	6010	286	3735	6060
137	3586	5911	187	3636	5961	237	3686	6011	287	3736	6061
138	3587	5912	188	3637	5962	238	3687	6012	288	3737	6062
139	3588	5913	189	3638	5963	239	3688	6013	289	3738	6063
140	3589	5914	190	3639	5964	240	3689	6014	290	3739	6064
141	3590	5915	191	3640	5965	241	3690	6015	291	3740	6065
142	3591	5916	192	3641	5966	242	3691	6016	292	3741	6066
143	3592	5917	193	3642	5967	243	3692	6017	293	3742	6067
144	3593	5918	194	3643	5968	244	3693	6018	294	3743	6068
145	3594	5919	195	3644	5969	245	3694	6019	295	3744	6069
146	3595	5920	196	3645	5970	246	3695	6020	296	3745	6070
147	3596	5921	197	3646	5971	247	3696	6021	297	3746	6071
148	3597	5922	198	3647	5972	248	3697	6022	298	3747	6072
149	3598	5923	199	3648	5973	249	3698	6023	299	3748	6073
150	3599	5924	200	3649	5974	250	3699	6024	300	3749	6074
151	3600	5925	201	3650	5975	251	3700	6025	301	3750	6075
152	3601	5926	202	3651	5976	252	3701	6026	302	3751	6076
153	3602	5927	203	3652	5977	253	3702	6027	303	3752	6077
154	3603	5928	204	3653	5978	254	3703	6028	304	3753	6078
155	3604	5929	205	3654	5979	255	3704	6029	305	3754	6079
156	3605	5930	206	3655	5980	256	3705	6030	306	3755	6080
157	3606	5931	207	3656	5981	257	3706	6031	307	3756	6081
158	3607	5932	208	3657	5982	258	3707	6032	308	3757	6082
159	3608	5933	209	3658	5983	259	3708	6033	309	3758	6083
160	3609	5934	210	3659	5984	260	3709	6034	310	3759	6084
161	3610	5935	211	3660	5985	261	3710	6035	311	3760	6085
162	3611	5936	212	3661	5986	262	3711	6036	312	3761	6086
163	3612	5937	213	3662	5987	263	3712	6037	313	3762	6087
164	3613	5938	214	3663	5988	264	3713	6038	314	3763	6088
165	3614	5939	215	3664	5989	265	3714	6039	315	3764	6089
166	3615	5940	216	3665	5990	266	3715	6040	316	3765	6090
167	3616	5941	217	3666	5991	267	3716	6041	317	3766	6091
168	3617	5942	218	3667	5992	268	3717	6042	318	3767	6092
169	3618	5943	219	3668	5993	269	3718	6043	319	3768	6093
170	3619	5944	220	3669	5994	270	3719	6044	320	3769	6094
171	3620	5945	221	3670	5995	271	3720	6045	321	3770	6095
172	3621	5946	222	3671	5996	272	3721	6046	322	3771	6096
173	3622	5947	223	3672	5997	273	3722	6047	323	3772	6097
174	3623	5948	224	3673	5998	274	3723	6048	324	3773	6098
175	3624	5949	225	3674	5999	275	3724	6049	325	3774	6099

ANASAT[®]-LMC Satellite Channels

Ch.	RX MHz	TX MHz	Ch.	RX MHz	TX MHz	Ch.	RX MHz	TX MHz	Ch.	RX MHz	TX MHz
326	3775	6100	376	3825	6150	426	3875	6200	476	3925	6250
327	3776	6101	377	3826	6151	427	3876	6201	477	3926	6251
328	3777	6102	378	3827	6152	428	3877	6202	478	3927	6252
329	3778	6103	379	3828	6153	429	3878	6203	479	3928	6253
330	3779	6104	380	3829	6154	430	3879	6204	480	3929	6254
331	3780	6105	381	3830	6155	431	3880	6205	481	3930	6255
332	3781	6106	382	3831	6156	432	3881	6206	482	3931	6256
333	3782	6107	383	3832	6157	433	3882	6207	483	3932	6257
334	3783	6108	384	3833	6158	434	3883	6208	484	3933	6258
335	3784	6109	385	3834	6159	435	3884	6209	485	3934	6259
336	3785	6110	386	3835	6160	436	3885	6210	486	3935	6260
337	3786	6111	387	3836	6161	437	3886	6211	487	3936	6261
338	3787	6112	388	3837	6162	438	3887	6212	488	3937	6262
339	3788	6113	389	3838	6163	439	3888	6213	489	3938	6263
340	3789	6114	390	3839	6164	440	3889	6214	490	3939	6264
341	3790	6115	391	3840	6165	441	3890	6215	491	3940	6265
342	3791	6116	392	3841	6166	442	3891	6216	492	3941	6266
343	3792	6117	393	3842	6167	443	3892	6217	493	3942	6267
344	3793	6118	394	3843	6168	444	3893	6218	494	3943	6268
345	3794	6119	395	3844	6169	445	3894	6219	495	3944	6269
346	3795	6120	396	3845	6170	446	3895	6220	496	3945	6270
347	3796	6121	397	3846	6171	447	3896	6221	497	3946	6271
348	3797	6122	398	3847	6172	448	3897	6222	498	3947	6272
349	3798	6123	399	3848	6173	449	3898	6223	499	3948	6273
350	3799	6124	400	3849	6174	450	3899	6224	500	3949	6274
351	3800	6125	401	3850	6175	451	3900	6225	501	3950	6275
352	3801	6126	402	3851	6176	452	3901	6226			
353	3802	6127	403	3852	6177	453	3902	6227			
354	3803	6128	404	3853	6178	454	3903	6228			
355	3804	6129	405	3854	6179	455	3904	6229			
356	3805	6130	406	3855	6180	456	3905	6230			
357	3806	6131	407	3856	6181	457	3906	6231			
358	3807	6132	408	3857	6182	458	3907	6232			
359	3808	6133	409	3858	6183	459	3908	6233			
360	3809	6134	410	3859	6184	460	3909	6234			
361	3810	6135	411	3860	6185	461	3910	6235			
362	3811	6136	412	3861	6186	462	3911	6236			
363	3812	6137	413	3862	6187	463	3912	6237			
364	3813	6138	414	3863	6188	464	3913	6238			
365	3814	6139	415	3864	6189	465	3914	6239			
366	3815	6140	416	3865	6190	466	3915	6240			
367	3816	6141	417	3866	6191	467	3916	6241			
368	3817	6142	418	3867	6192	468	3917	6242			
369	3818	6143	419	3868	6193	469	3918	6243			
370	3819	6144	420	3869	6194	470	3919	6244			
371	3820	6145	421	3870	6195	471	3920	6245			
372	3821	6146	422	3871	6196	472	3921	6246			
373	3822	6147	423	3872	6197	473	3922	6247			
374	3823	6148	424	3873	6198	474	3923	6248			
375	3824	6149	425	3874	6199	475	3924	6249			

Appendix E. Converting dBm to Watts and Watts to dBm

<u>dBm</u>	<u>W</u>	<u>W</u>	<u>dBm</u>
20.....	0.10	1	30.00
20.5.....	0.11	2	33.01
21.....	0.13	3	34.77
21.5.....	0.14	4	36.02
22.....	0.16	5	36.99
22.5.....	0.18	6	37.78
23.....	0.20	7	38.45
23.5.....	0.22	8	39.03
24.....	0.25	9	39.54
24.5.....	0.28	10	40.00
25.....	0.32	11	40.41
25.5.....	0.35	12	40.79
26.....	0.40	13	41.14
26.5.....	0.45	14	41.46
27.....	0.50	15	41.76
27.5.....	0.56	16	42.04
28.....	0.63	17	42.30
28.5.....	0.71	18	42.55
29.....	0.79	19	42.79
29.5.....	0.89	20	43.01
30.....	1.00	21	43.22
30.5.....	1.12	22	43.42
31.....	1.26	23	43.61
31.5.....	1.41	24	43.80
32.....	1.58	25	43.97
32.5.....	1.78	26	44.14
33.....	2.00	27	44.31
33.5.....	2.24	28	44.47
34.....	2.51	29	44.62
34.5.....	2.82	30	44.77
35.....	3.16	32	45.05
35.5.....	3.55	34	45.31
36.....	3.98	36	45.56
36.5.....	4.47	38	45.8
37.....	5.01	40	46.02
37.5.....	5.62	42	46.23
38.....	6.31	44	46.43
38.5.....	7.08	46	46.63
39.....	7.94	48	46.81
39.5.....	8.91	50	47.00
40.....	10.00	55	47.40
40.5.....	11.22	60	47.78
41.....	12.59	65	48.13
41.5.....	14.13	70	48.45
42.....	15.85	75	48.75
42.5.....	17.78	80	49.05
43.....	19.95	85	49.29
43.5.....	22.39	90	49.54
44.....	25.12	95	49.78
44.5.....	28.18	100	50.00

Appendix F. Transceivers Weights & Dimensions

EC, SEC, RC, PC, XC

	<u>Dimensions inches</u>	<u>Dimensions mm</u>	<u>Weight lbs</u>	<u>Weight kg</u>
0dBm	21.6" x 9.0" x 7.0"	549 x 229 x 178	23	10.5
2 watts	21.6" x 9.0" x 7.0"	549 x 229 x 178	27	12.3
5 watts	21.6" x 9.0" x 7.0"	549 x 229 x 178	29	13.2
10 watts	21.6" x 9.0" x 11.6"	549 x 229 x 295	32	14.5
20 watts	21.6" x 9.0" x 13.5"	549 x 229 x 343	39	17.7
30 watts	21.6" x 9.0" x 15"	549 x 229 x 381	57	25.9
40 watts	21.6" x 9.0" x 14"	549 x 229 x 356	45	20.5
50 watts	21.6" x 9.0" x 15"	549 x 229 x 381	57	25.9
60 watts	21.6" x 9.0" x 15"	549 x 229 x 381	57	25.9
70 watts	21.6" x 9.0" x 15"	549 x 229 x 381	57	25.9
80 watts	21.6" x 9.0" x 16"	549 x 229 x 407	60	27.3
100 watts	21.6" x 13" x 14"	549 x 330 x 356	75	34.1
125 watts	38.0" x 13" x 12.5"	965 x 330 x 318	102	47
150 watts	38.0" x 13" x 12.5"	965 x 330 x 318	102	47
180 watts	38.0" x 13" x 12.5"	965 x 330 x 318	136	62
200 watts	38.0" x 13" x 12.5"	965 x 330 x 318	136	62
300 watts	38.0" x 13" x 12.36"	965 x 648 x 314	280	127
350 watts	38.0" x 13" x 12.36"	965 x 648 x 314	280	127
400 watts	38.0" x 13" x 12.36"	965 x 648 x 314	280	127

Protection Switch

P. S.	8.5" x 9.5" x 4.0"	216 x 241 x 102	3.0	1.36
--------------	--------------------	-----------------	-----	------

LNC

C-Band	3.7" x 2.8" x 3.9"	91 x 71 x 99	0.70	0.32
---------------	--------------------	--------------	------	------

