

GENERAL DYNAMICS
SATCOM Technologies

4096-246
May 12, 2009
REVISION G

ASSEMBLY MANUAL

1.8M C-BAND Rx/Tx ANTENNA FEED SYSTEM

General Dynamics SATCOM Technologies
1500 Prodelin Drive
Newton NC 28658 USA
828-464-4141
www.gdsatcom.com

1.8M C-BAND Rx/Tx ANTENNA FEED SYSTEM

G	Revised Part Numbers	5/12/09	RAH
F	Changed Logo and Name	5/7/09	RAH
E	Revised Address	1/10/02	CLT
D	Added WR137 to Figures 2 and 3	12/15/97	PGW
C	Replace Feed Support 0490-302 with 0181-094 - ECN2238	0818 97	PGW
B	CHANGE QTY ITEM 4,5 TO 1 IN LINEAR FEED TBL. REVISE TEXT IN STEP 4 CIRC POL AND TEXT IN STEP 5.	8-8-95	R Frye
-	ORIGINAL RELEASE	8-7-92	R FRYE
REV.	DESCRIPTION	DATE	APPROVED

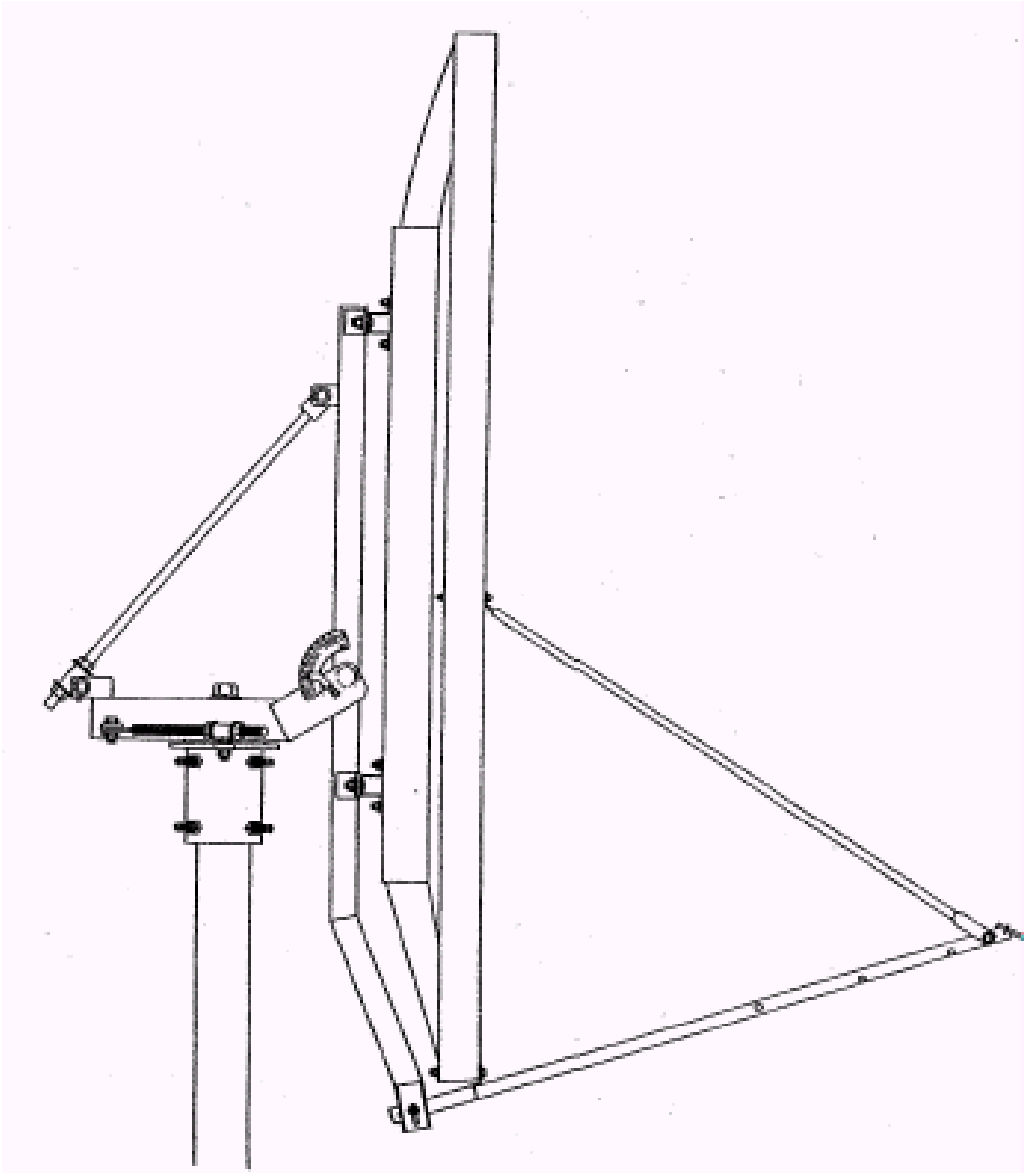

FEED SUPPORT ASSEMBLY

As shown in figure 1, assemble the following items in the listed sequence.

- Step 1: Attach the left and right hand feed rods (item# 2,3) to each side of the reflector using [2] 5/16-18 x 3.75" bolts, [4] flatwashers, [2] lockwasher, and [2] hex nuts (item# 6,7,8,9). See detail "A".
- Step 2: Before attaching the feed support tube, sight the bottom of the reflector with the reflector support tube, ensuring the reflector is centered. If not, move the reflector left or right on the cross arms then re-tighten the [4] 1/2-13 x 1.5" carriage bolts to the reflector crossarms. See detail "B".
- Step 3: Bolt the other end of each feed rod to the feed support tube (item# 1) with the 5/16-18 x 3.25" bolt, [2] flatwashers, [1] lockwasher and [1] hex nut (item# 5,7,8,9). See detail "C".
- Step 4: Mount the feed support tube loosely to the bottom of the reflector with [1] 5/16-18 x 3.75" bolt, [2] flatwashers, [1] lockwasher, and [1] hex nut (item# 6,7,8,9). See detail "D".
- Step 5: Attach the feed support tube between the flanges of the reflector support with the [2] 5/16-18 x 1.00" carriage bolts, [2] flatwashers, [2] lockwashers, and [2] hex nuts (item# 4,7,8,9). See detail "D". Tighten all hardware.

PARTS LIST - FEED SUPPORT ASSEMBLY			
ITEM#	PART#	DESCRIPTION	QTY
1	0181-094	FEED SUPPORT TUBE	1
2	0176-212	FEED ROD, LEFT-HAND	1
3	0176-211	FEED ROD, RIGHT-HAND	1
4	8038-006	BOLT, CARRIAGE, 5/16-18 x .75"	2
5	8031-026	BOLT, 5/16-18 x 3.25"	1
6	8031-030	BOLT, 5/16-18 x 3.75"	3
7	8201-041	FLATWASHER, 5/16"	12
8	8202-041	LOCKWASHER, 5/16"	6
9	8101-009	NUT, HEX, 5/16-18	6

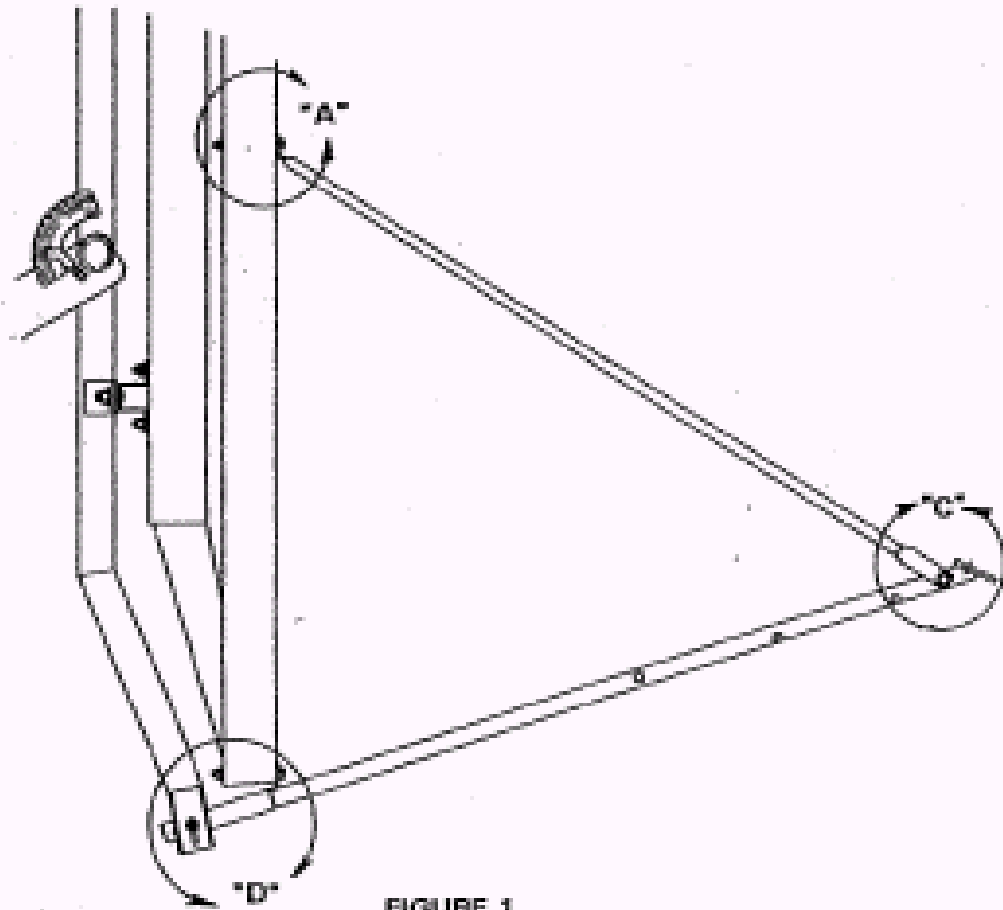
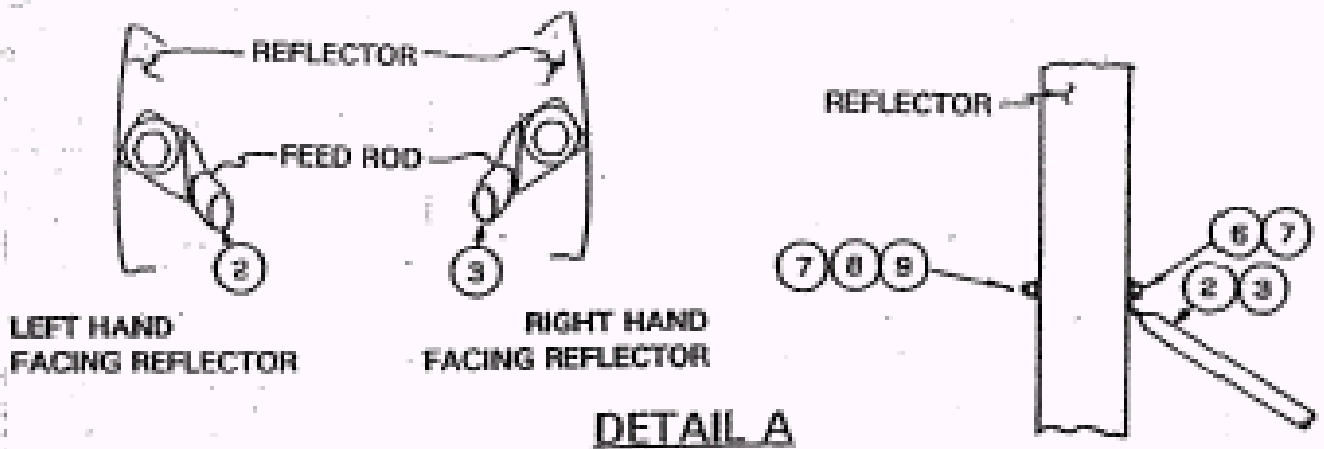
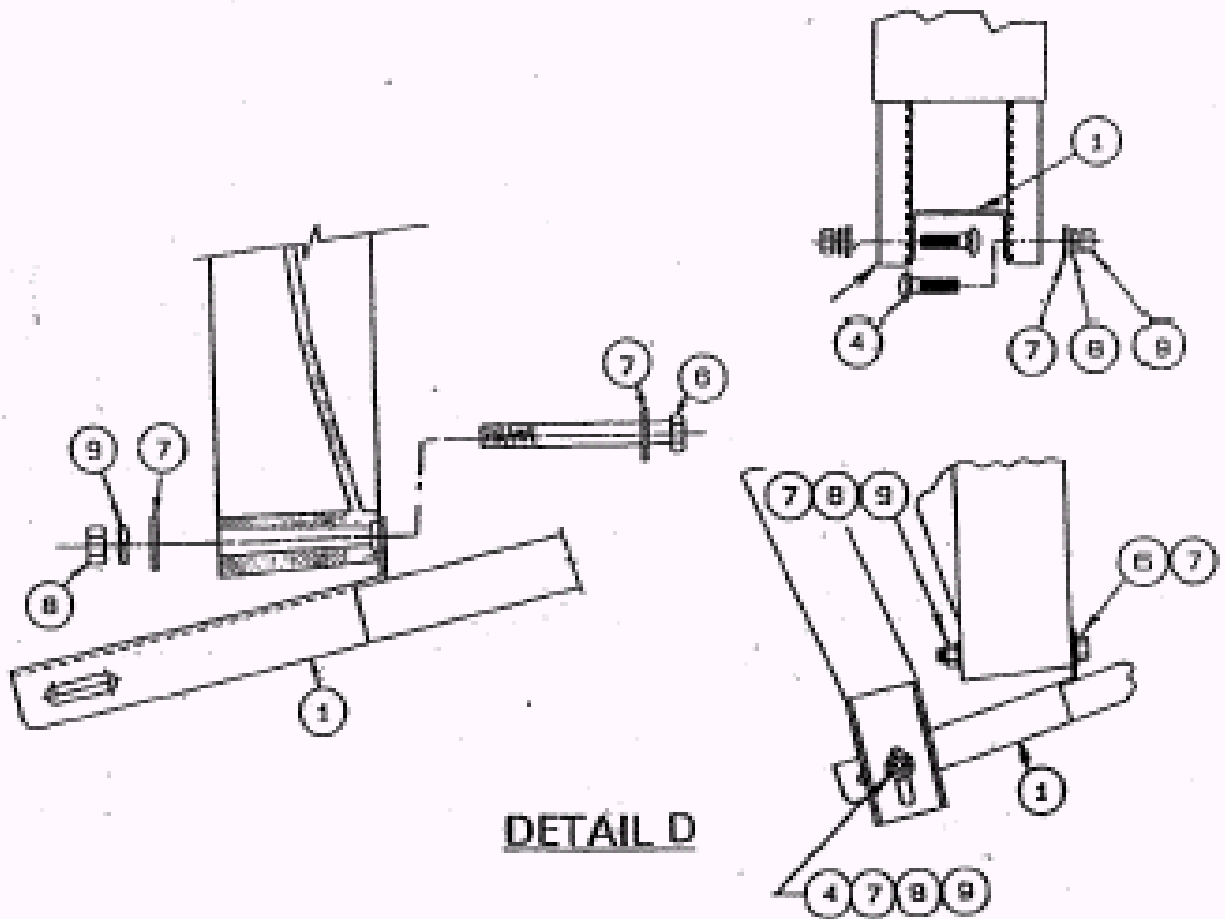
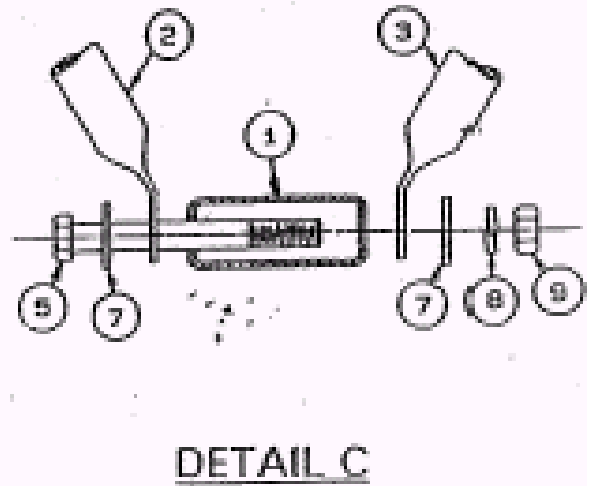
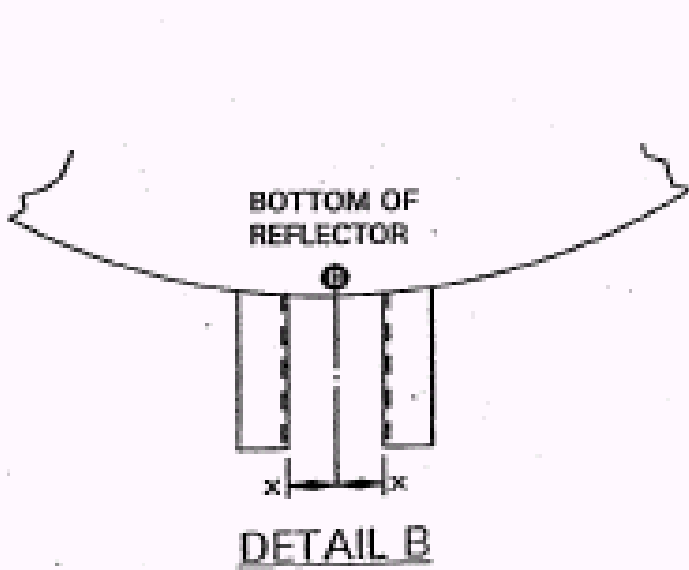

FIGURE 1





LINEAR FEEDS, CROSS-POL AND CO-POL

STEP 1: Apply silicone grease to the o-ring (item# 6) and place it in the groove in the OMT to be used. Mount the feed horn (item# 1) to the cross-pol OMT (item# 2) or co-pol OMT (item# 3) with [8] #10-24 x 1.25 screws, [16] #10 flatwashers, [8] #10 lockwashers, and [8] #10-24 hex nuts (item# 7,8,9,10). Tighten securely. **NOTE: The screws should be inserted from the feed horn side to prevent any interference.** See figure 2.

STEP 2: Attach the bottom feed mounting bracket (item# 4) to the feed support tube with [4] 3/8-16 x 1.25" bolts, [4] lockwashers, and [4] 3/8-16 hex nuts (item# 11,12,13). Tightened securely.

STEP 3: Place the neck of the feed horn/OMT assembly from step #1 into the feed mounting bracket and secure with the top feed mounting bracket (item# 5) using [2] 5/16-18 x 1.00" bolts, [2] lockwashers, and [2] 5/16-18 hex nuts (item# 14,15,16).

<u>ITEM#</u>	<u>PART#</u>	<u>DESCRIPTION</u>	<u>QUANTITY</u>
1	0183-317	FEED HORN	1
2	0183-340	CROSS-POL OMT	1
3	0183-341	CO-POL OMT	1
4	0211-420	FEED MOUNTING BRACKET	1
5	0211-419	FEED MOUNTING BRACKET-TOP	1
6	0198-124	O-RING	2
7	8302-007	#10-24 X 1.25 SCREW	8
8	8202-032	#10 LOCKWASHER	8
9	8111-005	#10-24 HEX NUT	8
10	8201-037	#10 FLATWASHER	16
11	8032-010	3/8-16 X 1.25" BOLT	4
12	8202-042	3/8" LOCKWASHER	4
13	8102-007	3/8-16 HEX NUT	4
14	8031-008	5/16-18 X 1.00" BOLT	2
15	8202-041	5/16" LOCKWASHER	2
16	8101-009	5/16-18 HEX NUT	2

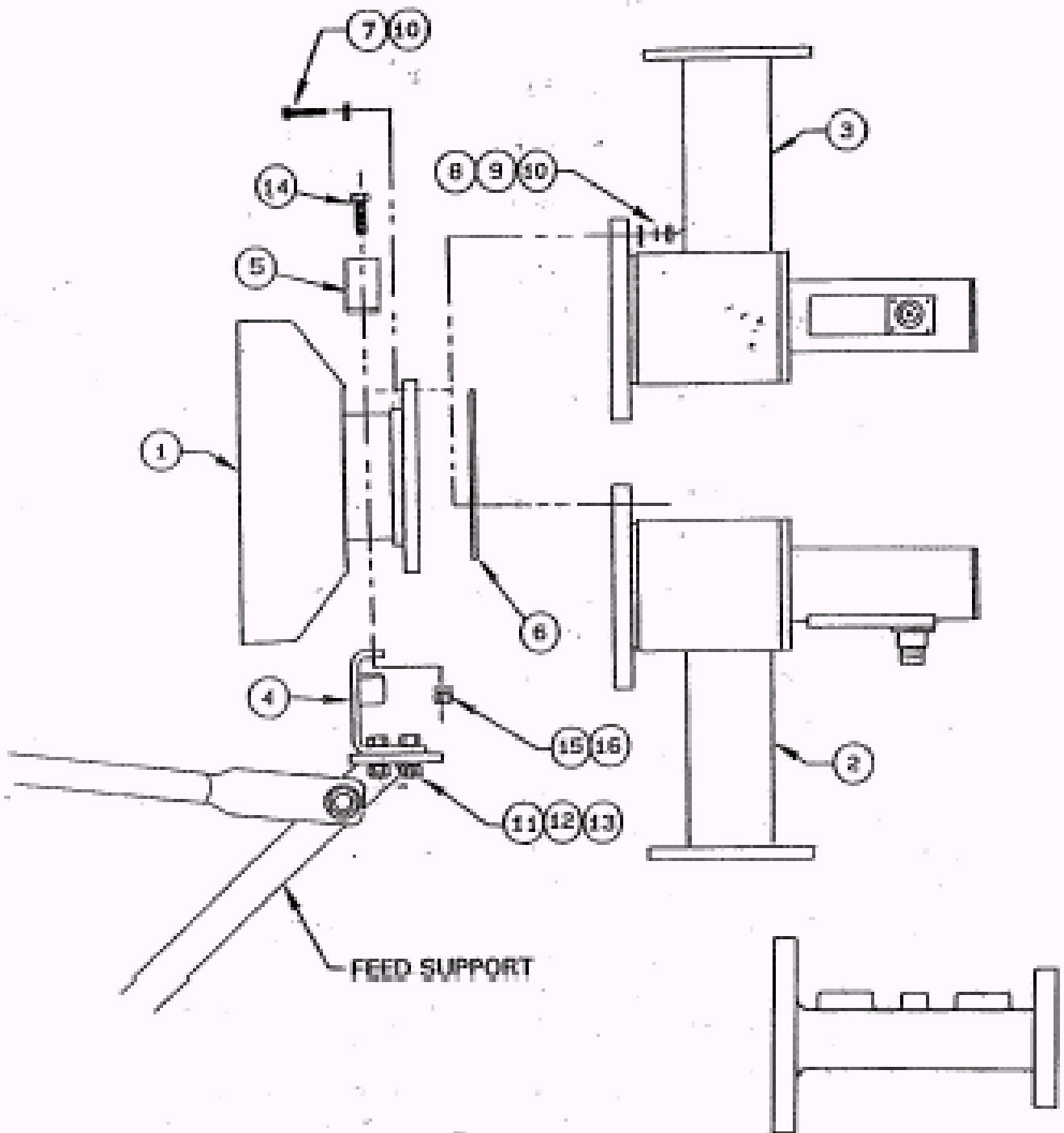

FIGURE 2

WR137

CIRCULAR POLARIZATION

Step 1: Apply silicone grease to [2] o-rings (item# 7) and place [1] in the o-ring groove in the circular polarizer (item# 3). Attach the feed horn (item# 1) to the circular polarizer (end with o-ring) with [8] #10-24 x 1.25" screws, [16] flatwashers, [8] lockwashers, and [8] #10-24 hex nuts (item# 8,9,10,11). Tighten securely. **NOTE: The screws should be inserted from the feed horn side to prevent any interference.** See figure 3.

Step 2: Bolt the OMT (item# 2) to the circular polarizer by placing the remaining O-ring in the groove of the OMT and fastening it to the circular polarizer with [8] #10-24 x 1.25" screws, [16] flatwashers, [8] lockwashers, and [8] #10-24 hex nuts (item# 8,9,10,11). **NOTE:** The screws should be inserted from the circular polarizer side to prevent interference. For left hand polarization, align the "LHCP" on the flange of the circular polarizer with the arrow on the OMT. For right hand polarization, align the "RHCP" with the arrow on the OMT. Tighten securely. **NOTE:** When a polarization setting is attempted, installers should keep in mind that right hand and left hand polarization refers to the transmission of signals from the feed to the reflector. Then the reflector reverses the signal. Therefore a "LHCP" feed system results in an antenna system that transmits a Right Hand Circular Polarized signal.

Step 3: Attach [1] bottom feed mounting bracket (item# 4) and the circular polarizer bracket (item# 6) to the feed support tube plate with [4] 3/8-16 x 1.25" bolts, [4] lockwashers, and [4] hex nuts (item# 13,14,15) through the feed mounting bracket, circular polarizer and feed support, as shown, and [1] 5/16-18 x 3.25" bolt, [1] lockwasher, and [1] hex nut (item# 18,19,20) through the circular polarizer bracket and feed support tube only. Tighten securely.

Step 4: Attach the remaining bottom feed mounting bracket (Item #4) to the circular polarizer bracket with [4] 3/8-16 x 1.00" bolts, [4] lockwashers, and [4] 3/8-16 hex nuts (item# 12,14,15). Do not tighten. **NOTE: Refer to figure 2.1-B to be sure that the brackets are oriented correctly.**

Step 5: Place the feed assembly from step #1 into the brackets and secure by fastening [1] top feed mounting bracket (item# 5) over the neck of the feed horn with [2] 5/16-18 x 1.00" bolts, [2] lockwashers, and [2] hex nuts (item# 16,19,20). Fasten the remaining top feed (Item #5) mounting bracket over the neck of the circular polarizer with [2] 5/16-18 x 1.50" bolts, [2] lockwashers, and [2] hex nuts (item# 17,19,20). Tighten the feed mounting bracket (from step #4) to the circular polarizer bracket. The antenna system is now ready to be aligned to the satellite.

<u>ITEM NO.</u>	<u>PART NO.</u>	<u>DESCRIPTION</u>	<u>QUANTITY</u>
1	0183-317	FEED HORN	1
2	0183-341	CROSS-POL OMT	1
3	0182-191	CIRCULAR POLARIZER	1
4	0211-420	FEED MOUNTING BRACKET	2
5	0211-419	FEED MOUNTING BRACKET-TOP	2
6	0181-715	CIRCULAR POLARIZER BRKT.	1
7	0198-124	O-RING	2
8	8302-007	#10-24 X 1.25" SCREW	16
9	8202-032	#10 LOCKWASHER	16
10	8111-005	#10-24 HEX NUT	16
11	8201-037	#10 FLATWASHER	32
12	8032-008	3/8-16 X 1.00" BOLT	4
13	8032-010	3/8-16 X 1.25" BOLT	4
14	8202-042	3/8" LOCKWASHER	8
15	8102-007	3/8-16 HEX NUT	8
16	8031-008	5/16-18 X 1.00" BOLT	2
17	8031-012	5/16-18 X 1.50" BOLT	2
18	8031-026	5/16-18 X 3.25" BOLT	1
19	8202-009	5/16" LOCKWASHER	5
20	8101-009	5/16-18 HEX NUT	5

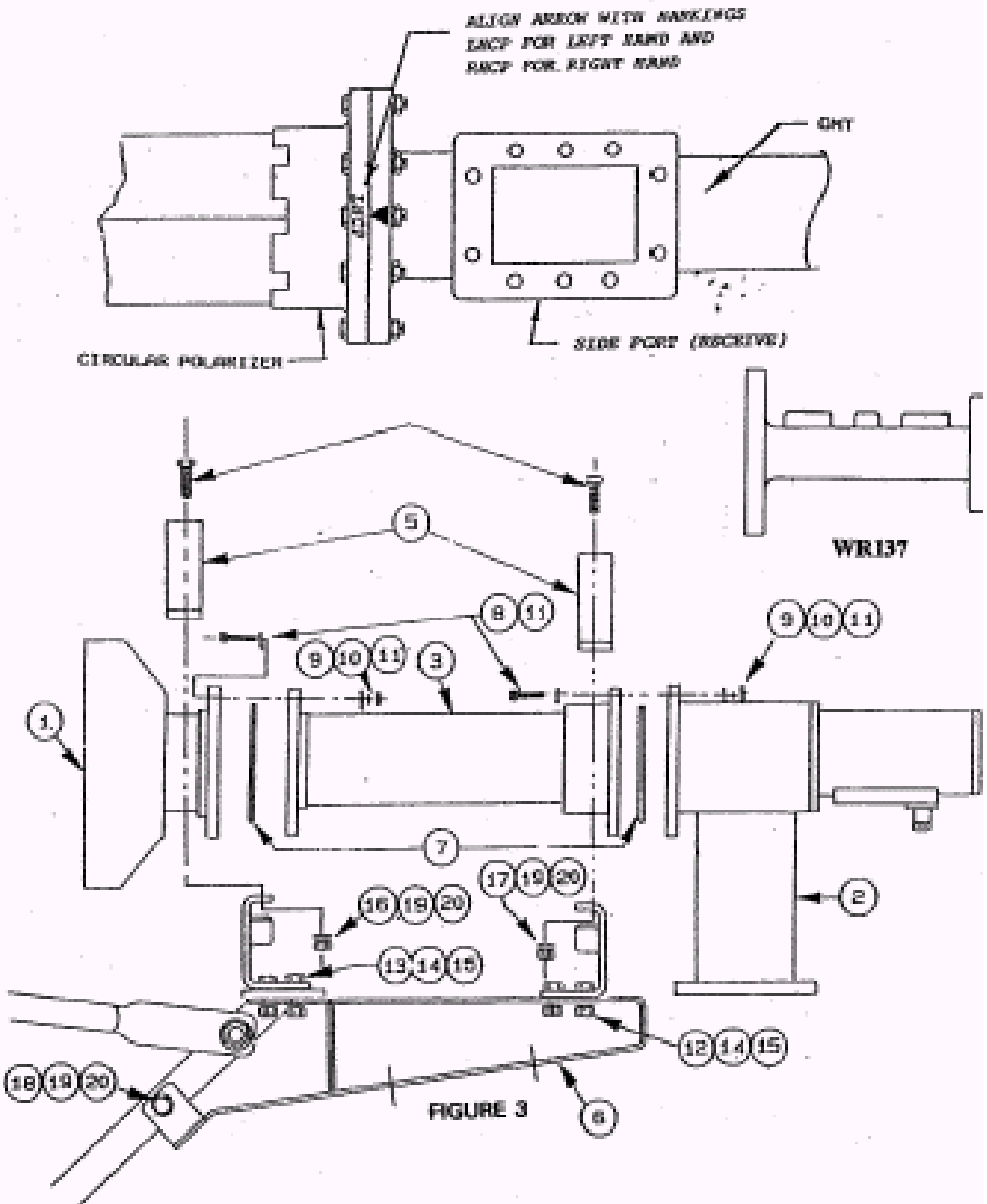

LNB/LNA ATTACHMENT

- STEP 1.** Apply silicone grease to gasket (item#1) and place gasket in groove in flange of LNA/LNB (customer supplied).
- STEP 2.** Attach LNA/LNB to side port (Rx) flange of OMT with (10) 1/4-20 x 1.00" bolts, (10) 1/4" flatwashers, (10) 1/4" lockwashers, and (10) 1/4-20 hex nuts (item# 2,3,4,5).
- STEP 3.** Tighten 1/4" hardware securely.

PARTS LIST - LNB/LNA ATTACHMENT			
ITEM#	PART#	DESCRIPTION	QTY
1	0171-073	GASKET, CPR WR2296 FLANGE HALF-THICK	1
2	8023-008	BOLT, 1/4-20 X 1.00" TYPE 304 S.S. STD.	10
3	8201-036	FLATWASHER, 1/4" S.S. STD.	10
4	8202-031	LOCKWASHER, 1/4" S.S. STD.	10
5	8100-005	NUT, HEX, 1/4-20 S.S. STD.	10

