



4096-666
August 19, 2004

ASSEMBLY MANUAL
Revision A

**1.2M Ku-BAND Rx/Tx
SERIES 1135
FEED SYSTEM**

PRODELIN CORPORATION
1500 Prodelin Drive
Newton NC 28658

**1.2M Ku-BAND Rx/Tx
 SERIES 1135
 FEED SYSTEM**

A	REVISED PER REVIEW	9/20/04	CLT
-	ORIGINAL RELEASE	8/18/04	CLT
REV.	DESCRIPTION	DATE	APPROVED

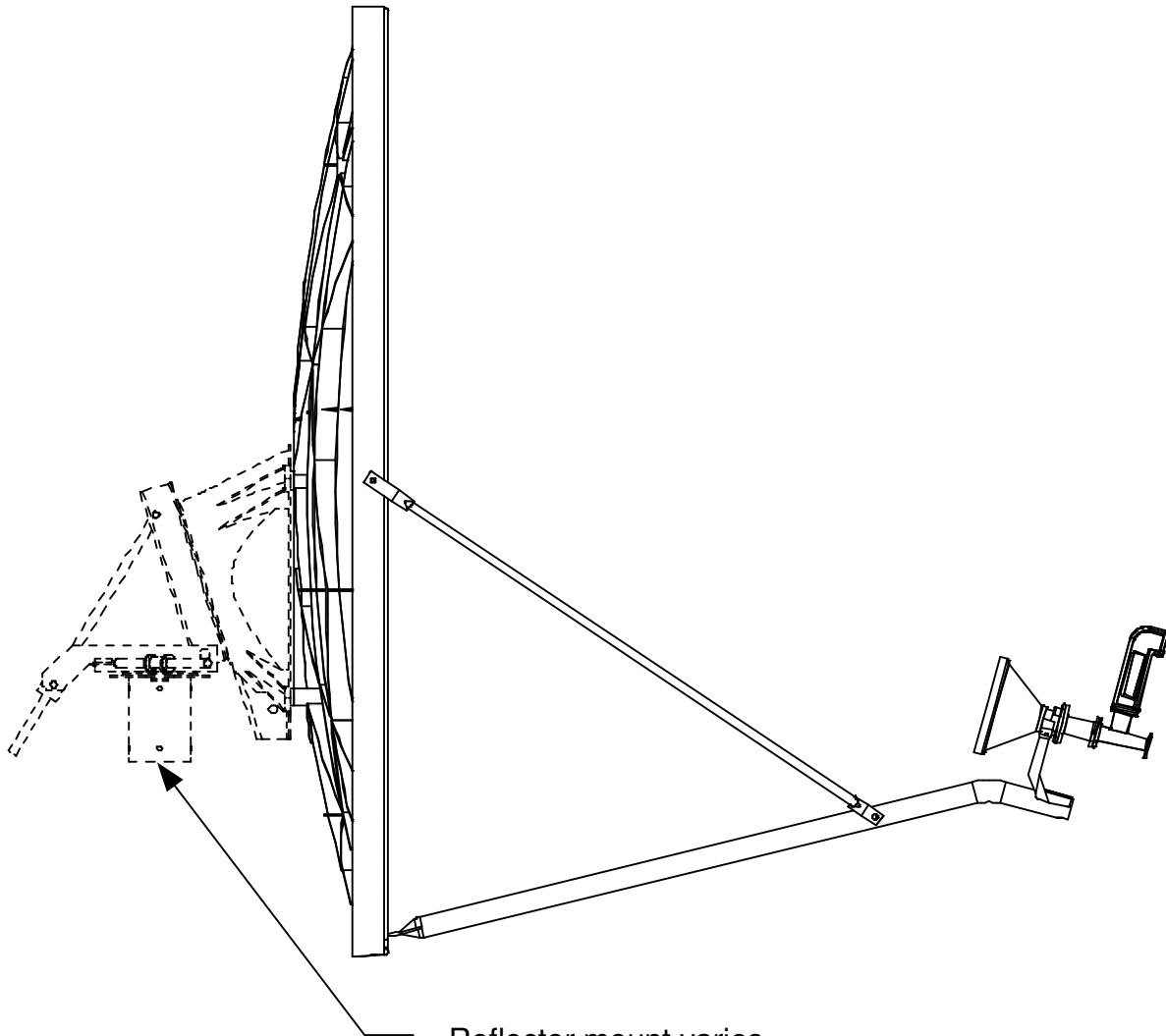

Reflector mount varies.
See instructions included
with the reflector mount.

1.2M TIER I ANTENNA SYSTEM
(Transmitter weight: 6-lbs. max)

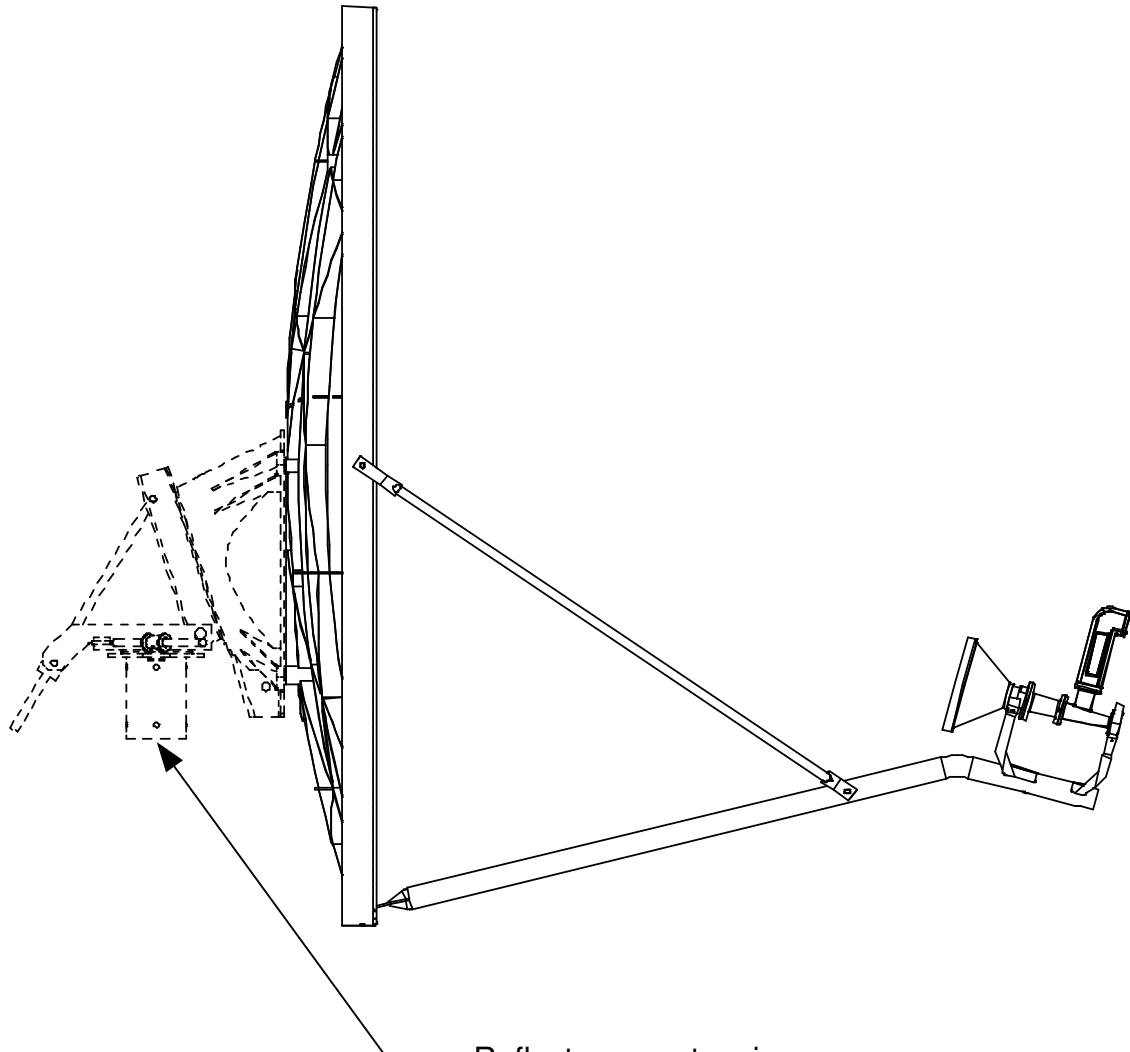

Reflector mount varies.
See instructions included
with the reflector mount.

1.2M TIER II ANTENNA SYSTEM
(Transmitter weight: 12-lbs. max)

TABLE OF CONTENTS

<u>SECTION</u>	<u>TITLE</u>
I	INTRODUCTION
1.0	GENERAL INFORMATION
1.1	UNPACKING & INSPECTION
1.2	FREIGHT DAMAGE
1.3	MATERIAL MISSING OR DAMAGED
1.4	MECHANICAL INSTALLATION TOOLS
II	FEED SUPPORT INSTALLATION
2.0	FEED SUPPORT ASSY PARTS LIST
2.1	FEED SUPPORT ASSEMBLY
III	FEED INSTALLATION
3.0	SETTING POLARIZATION
3.1	FEED / OMT ASSY PARTS LIST
3.2	FEED / OMT ASSEMBLY
3.3	FEED INSTALLATION PARTS LIST
3.4	FEED INSTALLATION
3.5	FINE ADJUSTMENT
IV	MAINTENANCE
4.0	MAINTENANCE OVERVIEW
4.1	FEED & FEED SUPPORT

SECTION I INTRODUCTION

1.0 GENERAL INFORMATION

This manual describes the assembly and installation of Prodelin's 1.2 meter Tier I and Tier II feed systems. The Prodelin 1.2 meter will operate in the Ku-Band frequency with high efficiency and at the same time successfully withstand the effects of the environment.

These instructions, listed by sections, cover all areas of assembly and installation. Additional sections are included in the manual to provide information on antenna peaking and maintenance.

1.1 UNPACKING AND INSPECTION

The system containers should be unpacked and inspected at the earliest date to insure that all material has been received and is in good condition. A complete packing list for each major component is supplied.

1.2 FREIGHT DAMAGE

Any damage to materials while in transit should be immediately directed to the freight carrier. They will instruct you on matters regarding any freight damage claims.

1.3 MATERIAL – MISSING OR DAMAGED

Any questions regarding missing or damaged materials that are not due to the freight carrier should be directed to Prodelin's Customer Service Department at:



PRODELIN CORPORATION
1500 Prodelin Drive
Newton NC 28658
USA
(828) 464-4141

1.4 MECHANICAL INSTALLATION TOOLS

HARDWARE SIZE	SAE WRENCH SIZE	METRIC WRENCH SIZE	MAX RECOMMENDED TORQUE
1/4" Bolt	7/16"	N/A	6 ft-lb. (8.1 n-m)
#6 SHCS	7/64" Allen	N/A	15 in-lb. (1.7 n-m)

Also recommended for installation:
-Adjustable Wrench

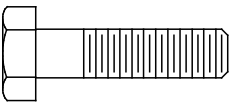
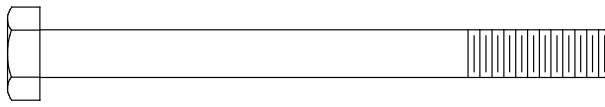
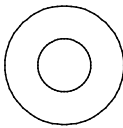
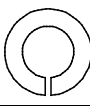
SECTION II FEED SUPPORT ASSEMBLY

FEED SUPPORT PART LIST - TABLE 2.0			
ITEM	PART NO.	DESCRIPTION	QTY
1	VARIABLES	1.2M Feed Rod	2
2	VARIABLES	1.2M Feed Support Tube	1
3	8031-008	5/16" x 1.00 Hex Bolt 	3
4	8031-016	5/16" x 2.00 Hex Bolt 	1
5	8201-071	5/16" Flatwasher 	8
6	8202-041	5/16" Lockwasher 	4
7	8101-009	5/16" Hex Nut 	4

2.1 FEED SUPPORT ASSEMBLY

CAUTION: During the assembly procedure, the sequence of instructions must be followed. **DO NOT TIGHTEN ANY HARDWARE UNTIL INSTRUCTED.** Refer to the feed support parts list and steps.

STEP 1.

Attach the long end of the feed rods to the reflector with 5/16" x 1.00 bolt (item 3) and secure with 5/16" hardware (items 5, 6, 7). See Detail "A".

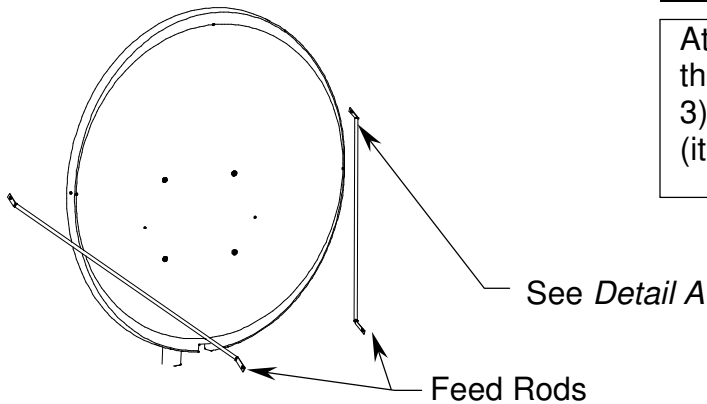

STEP 2.

Connect the short ends of the feed rods to the feed support tube with 5/16" x 2.00 bolt (item 4) and secure with hardware (items 5, 6, 7). See Detail "B".

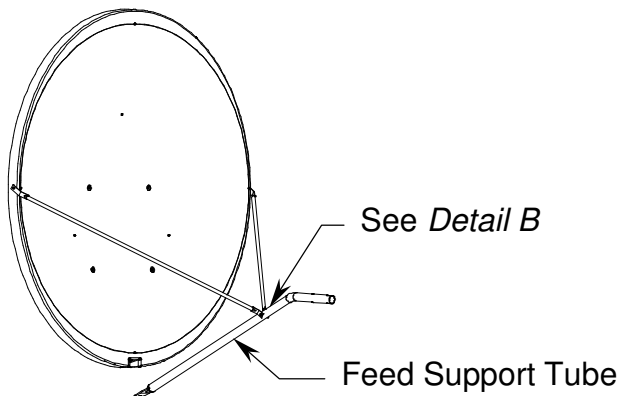

STEP 3.

- A) Attach feed support tube to the bottom of the reflector with 5/16" x 1.00 bolt (item 3) and secure with hardware (items 5, 6, 7).
- B) Tighten the 5/16" hardware at the reflector rim snugly. Next, tighten the hardware that connects the feed rods to the feed support tube.
- C) Refer to Section III instructions for the specific feed/ODU assembly to the feed support.

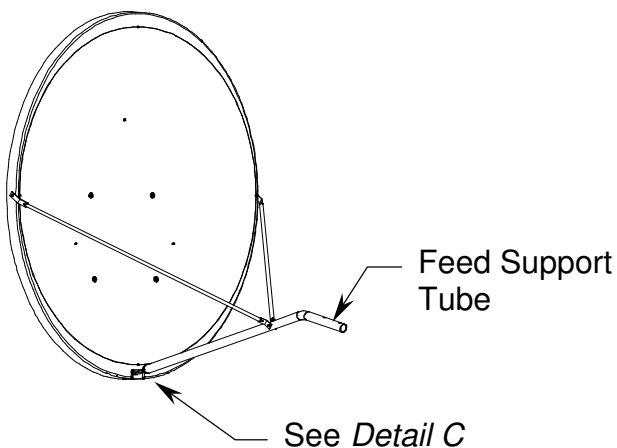

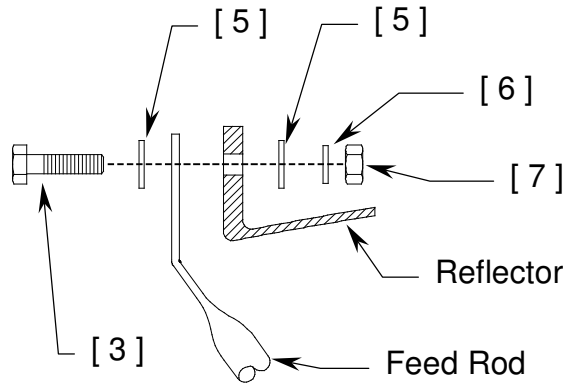

Detail A

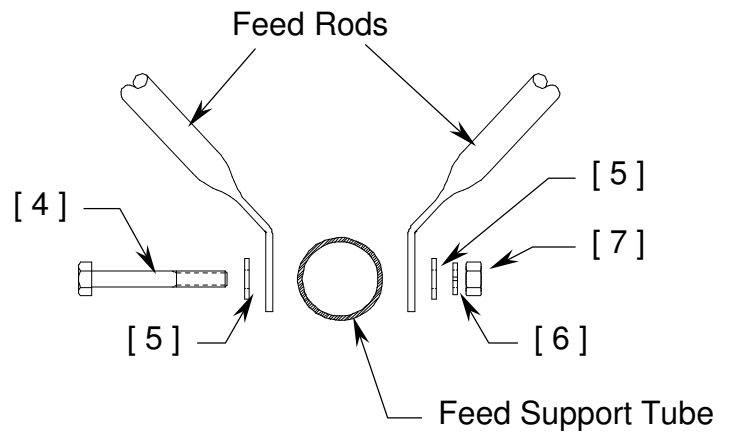

Detail B

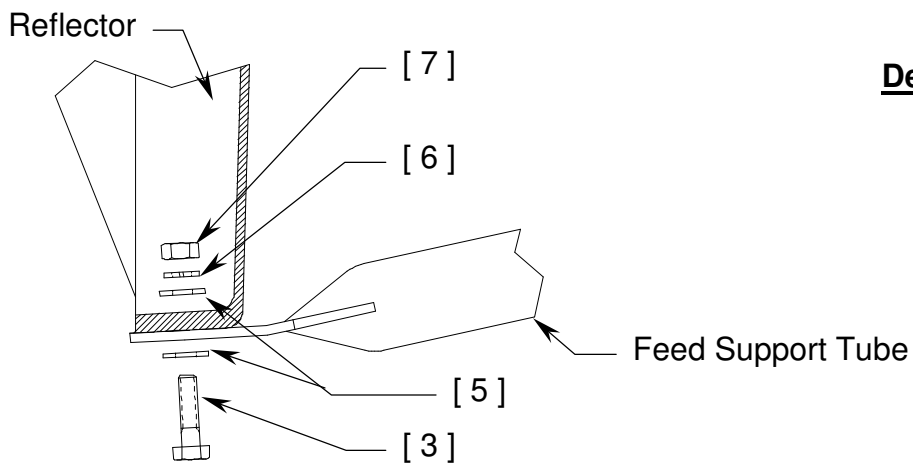

Detail C

SECTION III

3.0 SETTING POLARITY

Before assembling the Feed Horn Assy to the OMT, Determine whether vertical or horizontal polarity is required.

NOTE:

To polarize the feed vertical, align the side port of the OMT with the single mark on the Feed Horn Assy.

To polarize the feed horizontal, align the side port of the OMT with the double mark on the Feed Horn Assy.

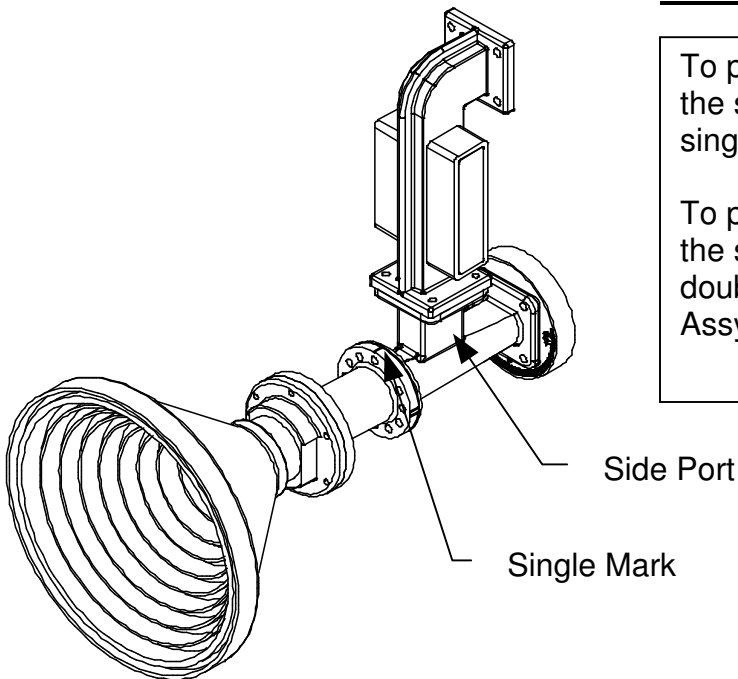

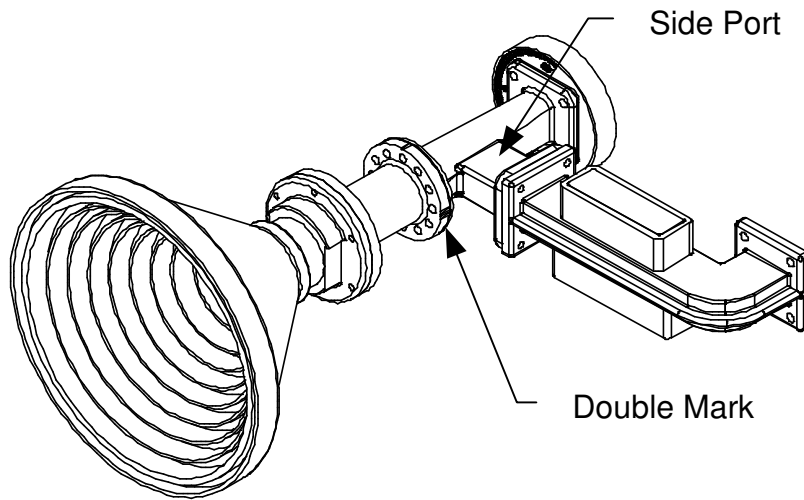

VERTICAL POLARITY



HORIZONTAL POLARITY

FEED /OMT ASSEMBLY PARTS LIST- TABLE 3.1

ITEM	PART NO.	DESCRIPTION	QTY
1	0183-721	39° Feed Horn Assy	1
2	0183-524	OMT Filter Assy	1
3	4080-050	Waveguide Spacer	1
4	0198-120	.926 I.D. x .070 O-ring	1
5	0198-121	1.176 I.D. x .070 O-ring	1
6	8300-002	#6-32 x .50 SHMS 	6
7	8308-026	M4 x 7.25 SHMS 	4
8	8201-064	M4 Flatwasher	4
9	8202-059	M4 Internal Tooth Lockwasher	4
10	8200-010	#6 Internal Tooth Lockwasher	6
11	0268-003	7/64" Allen Wrench	1
12	0268-004	3mm Allen Wrench	1
13	0432-036	Grease Pill	1

3.2 FEED / OMT ASSEMBLY

After polarity is determined, the feed can be assembled using the configurations from section 3.0. Refer to section 3.0 for assembly configurations.

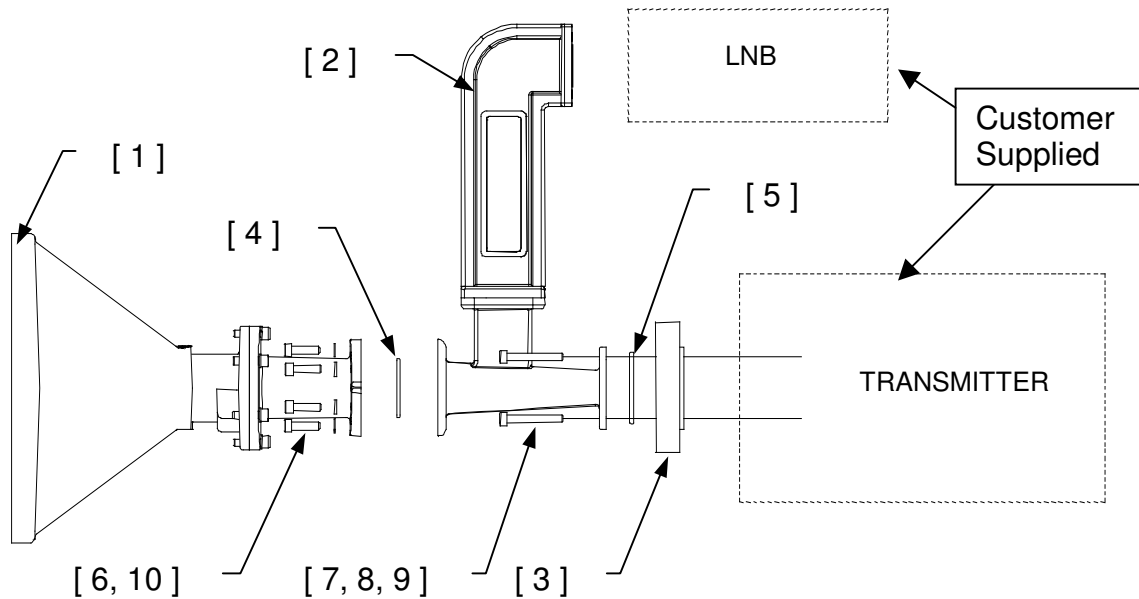

STEP 1.

Apply Silicone grease (item 13) to the entire o-ring (item 4). Place the O-ring (item 4) into the o-ring groove of the Feed Horn Assy (item 1). Hold the OMT Assy (item 2) against the Feed Horn Assy as shown. Be sure to install the OMT Assy in the correct polarization (refer to section 3.0). Attach the two assemblies using the #6 hardware (items 6, 10). It is recommended to lightly snug all six screws (item 6), and then tighten equally to the recommended torque with the 7/64" allen wrench (item 11) provided.

STEP 2.

Apply Silicone grease (item 13) to the entire o-ring (item 5) and place the o-ring in the o-ring groove of the Waveguide Spacer (item 3). Place the Waveguide Spacer (item 3) between the OMT Assy (item 2) and the transmitter (supplied by the customer) and secure using the M4 hardware provided (items 7, 8, 9).

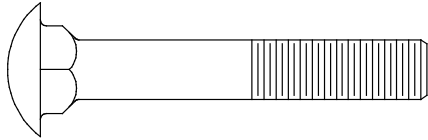
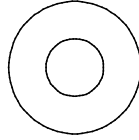
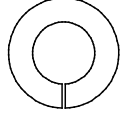
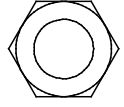
FEED INSTALLATION PARTS LIST- TABLE 3.3			
ITEM	PART NO.	DESCRIPTION	QTY
1	N/A	Feed / OMT Assembly (from section 3.2)	1
2	4080-189	Tube Mount Feed Cradle	1
3*	4080-190	Tube Mount Rear Support	1*
4	8400-001	1/4" x 1.00 Bolt 	2 4*
5	8044-016	1/4" x 2.00 Carriage Bolt 	1 2*
6	8201-040	1/4" Flatwasher 	1 2*
7	8202-040	1/4" Lockwasher 	3 6*
8	8101-007	1/4" Hex Nut 	1 2*
9	4080-194	Casting, Feed Horn Clamp	1
10	0188-156	Collar, Rear Support	1

* Indicates Tier II Antenna Configuration parts (12lb max transmitter weight)

3.4 FEED INSTALLATION

CAUTION: During the assembly procedure, the sequence of instructions must be followed. ***Do Not Tighten Any Hardware Until Instructed.***
Refer to the parts list table and the referenced steps.

Note: * indicate parts and procedures only for Tier II Antennas. All other parts and procedures apply to Tier I and Tier II antennas. Phantom lines indicate parts only for Tier II Antennas.

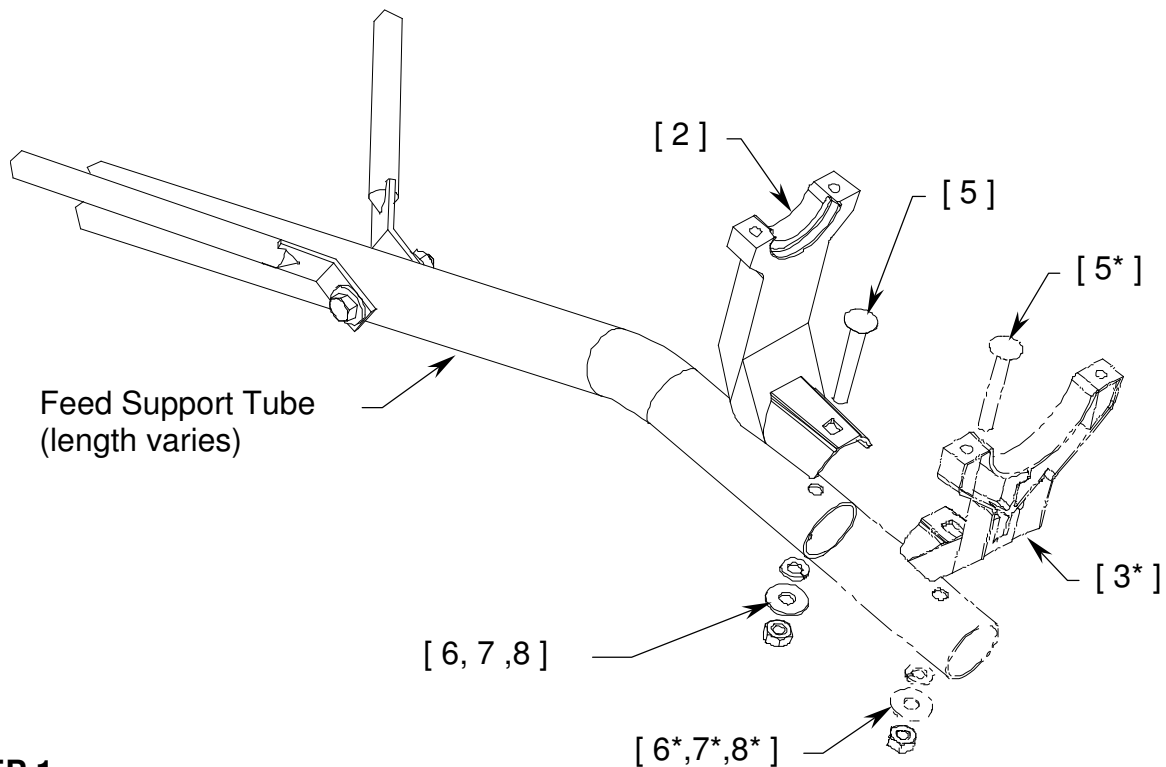

STEP 1.

Attach the Feed Cradle (item 2) to the Feed Support Tube using the 1/4-20 hardware provided (items 5, 6, 7, 8). Tighten to recommended torque.

Attach the Rear Support (item 3) to the Feed Support Tube using the 1/4-20 hardware provided (items 5*, 6*, 7*, 8*). Leave this hardware loose.

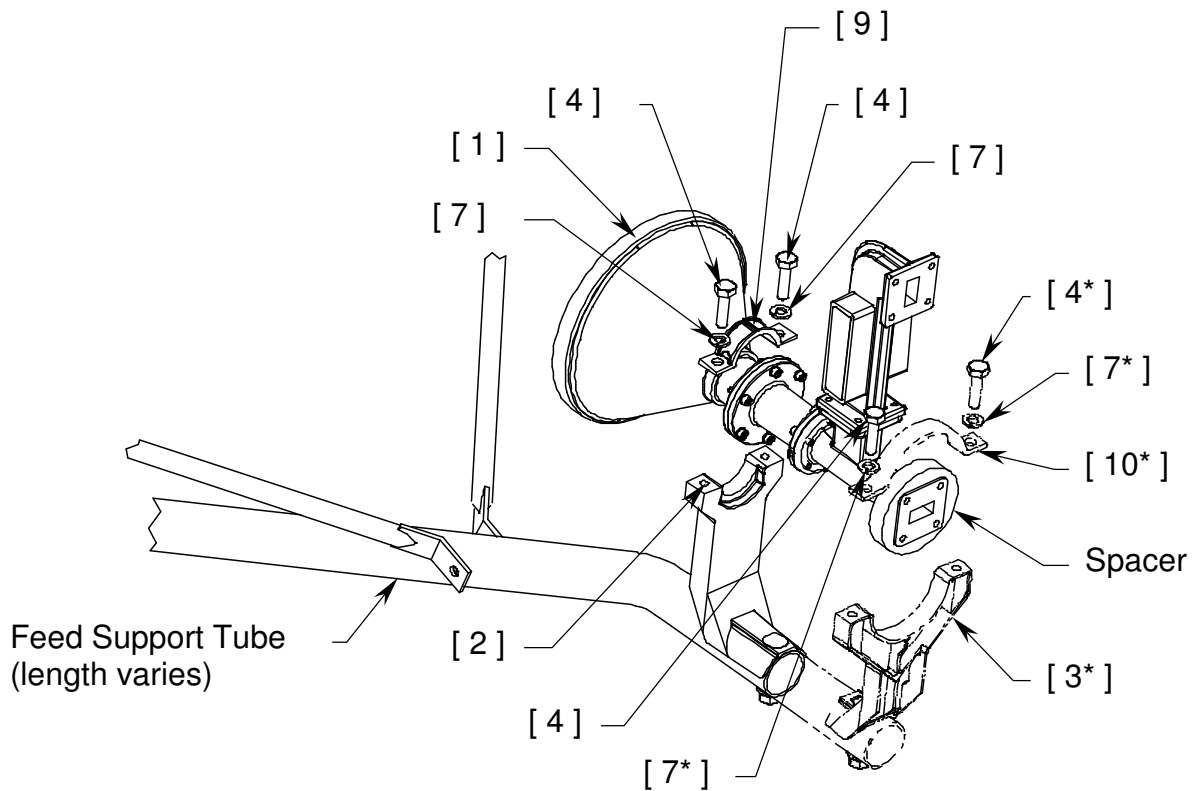

STEP 2.

Insert the feed horn (item 1) into the feed cradle (item 2) (see detail "D"). Place the clamp (item 9) over the feed horn and insert the two 1/4" bolts (item 4) with lockwashers (item 7) as shown.

Tier II antennas using a rear support (item 3): After installing the feed horn (item 1), position the rear support (item 3*) under the spacer. Place the rear clamp (item 10) over the spacer and attach using the provided 1/4" hardware (item 4 and 7).

Leave the 1/4" hardware loose until instructed to tighten.

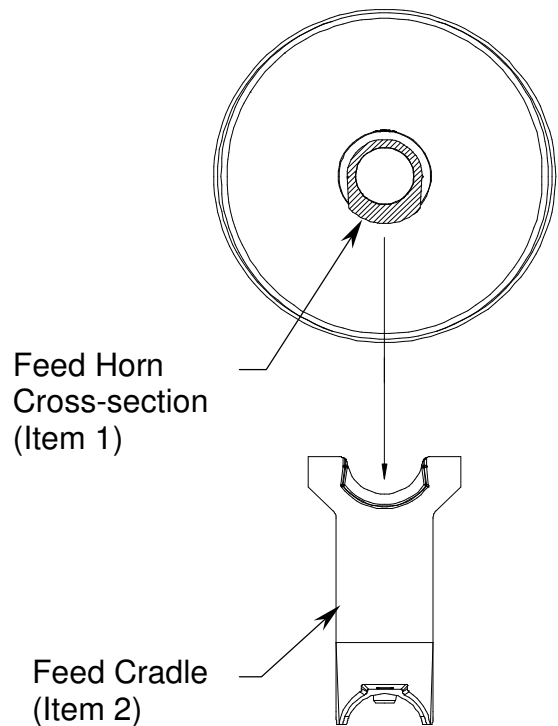

Detail "D"

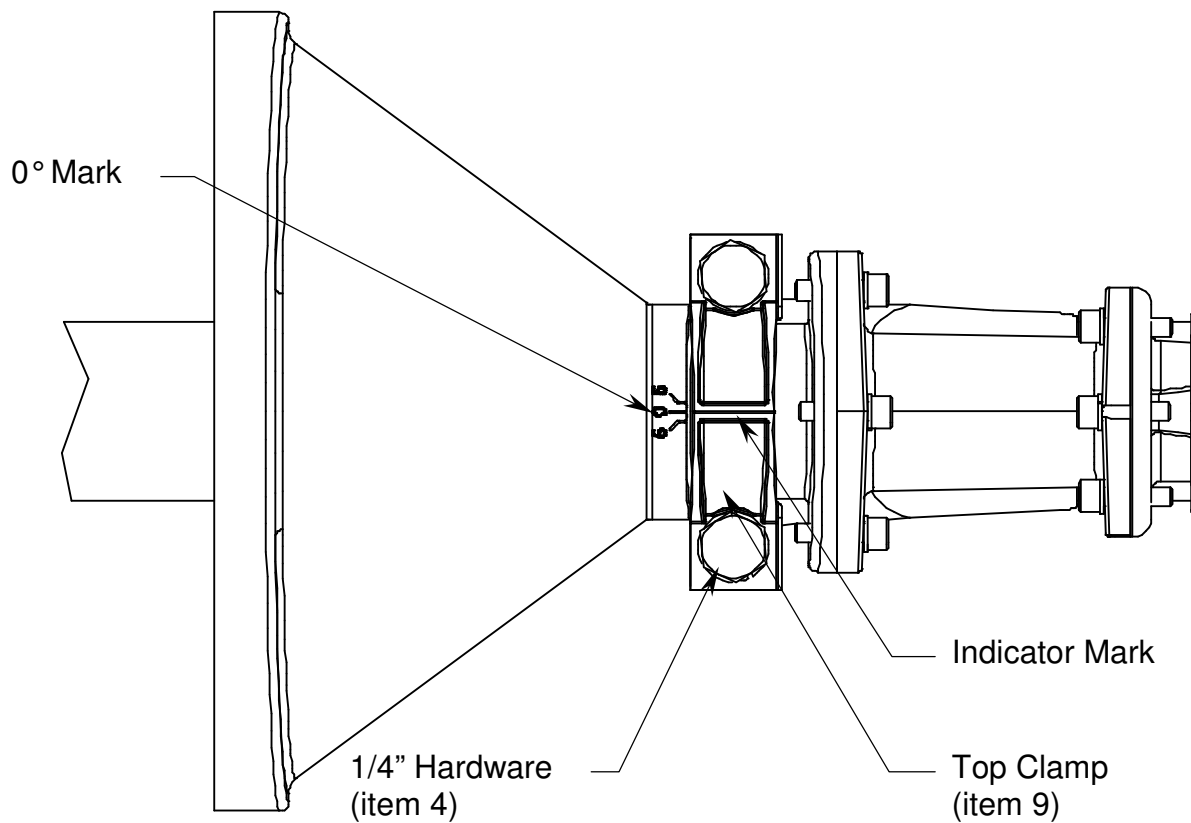
**STEP 3.**

Align the 0° mark on the feed horn to the indicator mark on the clamp. Use this for the initial setting of the feed horn.

Tighten all 1/4" hardware on the Top Clamp.

*For Tier II Feed Systems, tighten the 1/4" hardware on the rear collar also.

3.5 FINE ADJUSTMENT

This section describes the procedure for fine adjustment of polarization.

NOTE: Before proceeding with this section, the antenna should be peaked, using the az/el, in azimuth, elevation, and polarization. Refer to Antenna Installation manual for details on this procedure.

After the antenna is peaked using the az/el, the feed can be adjusted to give the installer additional fine adjustment for polarization.

NOTE: Refer to FEED INSTALLATION PARTS LIST- TABLE 3.3

STEP 1: If the clamp and or collar have been tightened, loosen the 1/4" Screws (item 4).

STEP 2: Rotate the feed left or right until the optimum signal is achieved.
Note: The feed will only adjust $\pm 7^\circ$.

Do not attempt to force the feed to move further than the built in stops.

STEP 3: Tighten all hardware used for adjustment.

SECTION IV MAINTENANCE

4.0 MAINTENANCE OVERVIEW

After installation, the antenna requires only periodic inspection. It is anticipated that maintenance, if required, will be minimal and easily handled by a local or in-house maintenance staff.

4.1 FEED AND FEED SUPPORT

The feed support and feed rods should be inspected to insure that all hardware is secure. The feed/radio mounting bolts should be tight.

The feed horn window should be inspected to insure that it is intact so that no moisture can collect inside the feed horn.