

GENERAL DYNAMICS

SATCOM Technologies

4096-349
July 14, 2009
REVISION I

ASSEMBLY MANUAL

6-1/2 FT. x 6-1/2 FT.
NON-PENETRATING MAST MOUNT

General Dynamics
SATCOM Technologies
1500 PRODELIN DRIVE
NEWTON, NC 28658

6-1/2' x 6-1/2' NPMM INSTALLATION INSTRUCTIONS

I	Revised Company Name, Logo, and Part Tables	7/14/09	RAH
H	Revise Angles to 0225-693,695, & 696	7/12/05	RAH
G	Del 0225-543 add 0225-694	5/9/05	A.Hahn
F	Revised Address	4/8/02	A. Hahn
E	Added Metric Tables	9/26/97	PGW
D	Updated	5-31-97	PGW
C	Revised rubber pads & figures	8-23-96	R Frye
B	Revised Hardware size (item 9 Pg. 6)	07-17-95	R Frye
A	Revised qty & placement of rubber pads per ECN #1678	08/24/94	R Frye
-	ORIGINAL RELEASE	03/09/94	R FRYE
REV.	DESCRIPTION	DATE	APPROVED

ASSEMBLY MANUAL

NON-PENETRATING MAST MOUNT

TABLE OF CONTENTS

<u>SECTION</u>	<u>TITLE</u>
I	GENERAL INFORMATION
1.0	GENERAL INFORMATION
1.1	UNPACKING & INSPECTION
1.2	SUGGESTED TOOL LIST
1.3	PARTS LIST
II	ASSEMBLY INSTRUCTIONS
III	BALLAST REQUIREMENTS
3.0	BALLAST REQUIREMENTS TABLE
3.1	BALLAST REQUIREMENTS INFORMATION

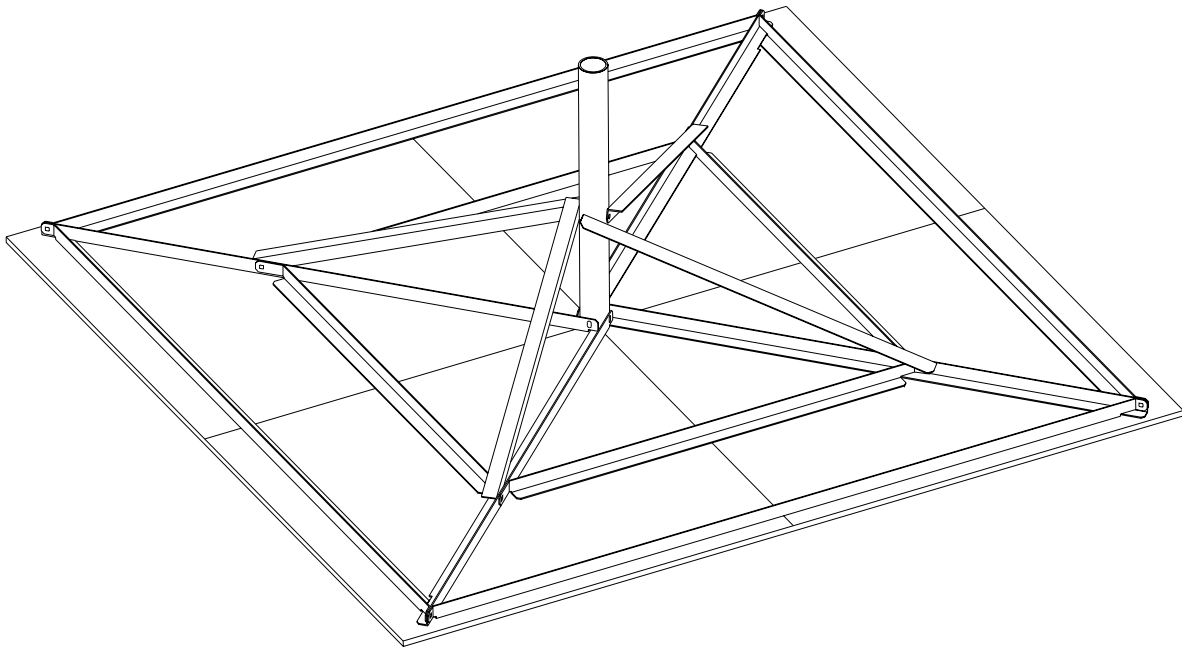

Figure 1

SECTION I

1.0 GENERAL INFORMATION

1. Prior to installation, verify that the installation site roof material and supporting structure have been investigated and found capable of withstanding all loads imposed by the proposed antenna system. Confirm that the supporting surfaces, anchors, and/or safety cables, if required, have been found to be adequate to resist the reactions from the antenna system and that the installation will be in accordance with all applicable local, state, and federal requirements.
2. All antenna installations should be grounded to meet all applicable codes.
3. Rubber pads are provided to protect the roof surface.
4. All necessary hardware is provided.
5. For assistance in determining ballast requirements refer to chart in section 3.
6. All metal parts are of galvanized construction to help prevent corrosion.

1.1 UNPACKING & INSPECTION

1. **UNPACKING & INSPECTING**
The mount should be unpacked and inspected at the earliest date to ensure that all material has been received and is in good condition. A complete packing list for each major component is supplied.
2. **FREIGHT DAMAGE**
Any damage to materials while in transit should be immediately directed to the freight carrier. He will instruct you on the matters regarding any freight damage claims.
3. **MATERIAL - MISSING OR DAMAGED**
Any questions regarding missing or damaged materials that is not due to freight carrier should be directed to General Dynamics' Customer Service Department at:

General Dynamics SATCOM Technologies
1500 Prodelin Drive
Newton, NC 28658
USA
(828) 464-4141

1.2 **SUGGESTED TOOL LIST**

1. SITE PREPARATION TOOLS

The following tools are suggested for site preparation.

1. Shovel (for ground installation)
2. Broom

2. SUGGESTED TOOL LIST

The following tools are suggested for the NPMM installation.

1. Ratchet
2. Socket, 9/16"
3. Wrench, combination 9/16"
4. Tape measure

1.3 PARTS LIST

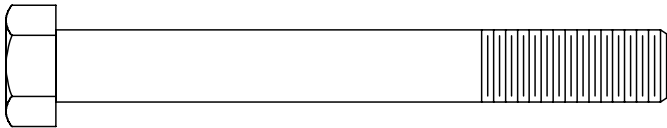
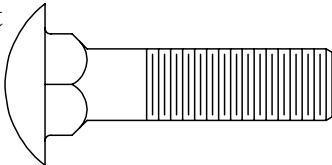
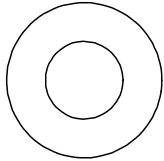
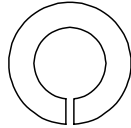
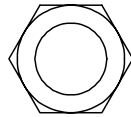
PARTS LIST - 6 1/2' x 6 1/2' NPMM			
ITEM NO.	PART NO.	DESCRIPTION	QTY
1	0184-179	Mast Pipe	1
2	0225-693	Outer Base Angle	4
3	0225-695	Inner Base Angle	4
4	0225-696	Diagonal Base Angle	4
5	0225-694	Mast Brace Angle	4
6	5003-036	0.45" x 27" x 42" Pad	6
7	8032-032 8032-036	3 / 8" x 4.00" Bolt 3 / 8" x 4.50" Bolt 	2 2
8	8039-012	3 / 8" x 1.50" Carriage Bolt 	8
9	8201-042	3 / 8" Flat Washer 	16
10	8202-042	3 / 8" Lock Washer 	12
11	8102-007	3 / 8" Hex Nut 	12

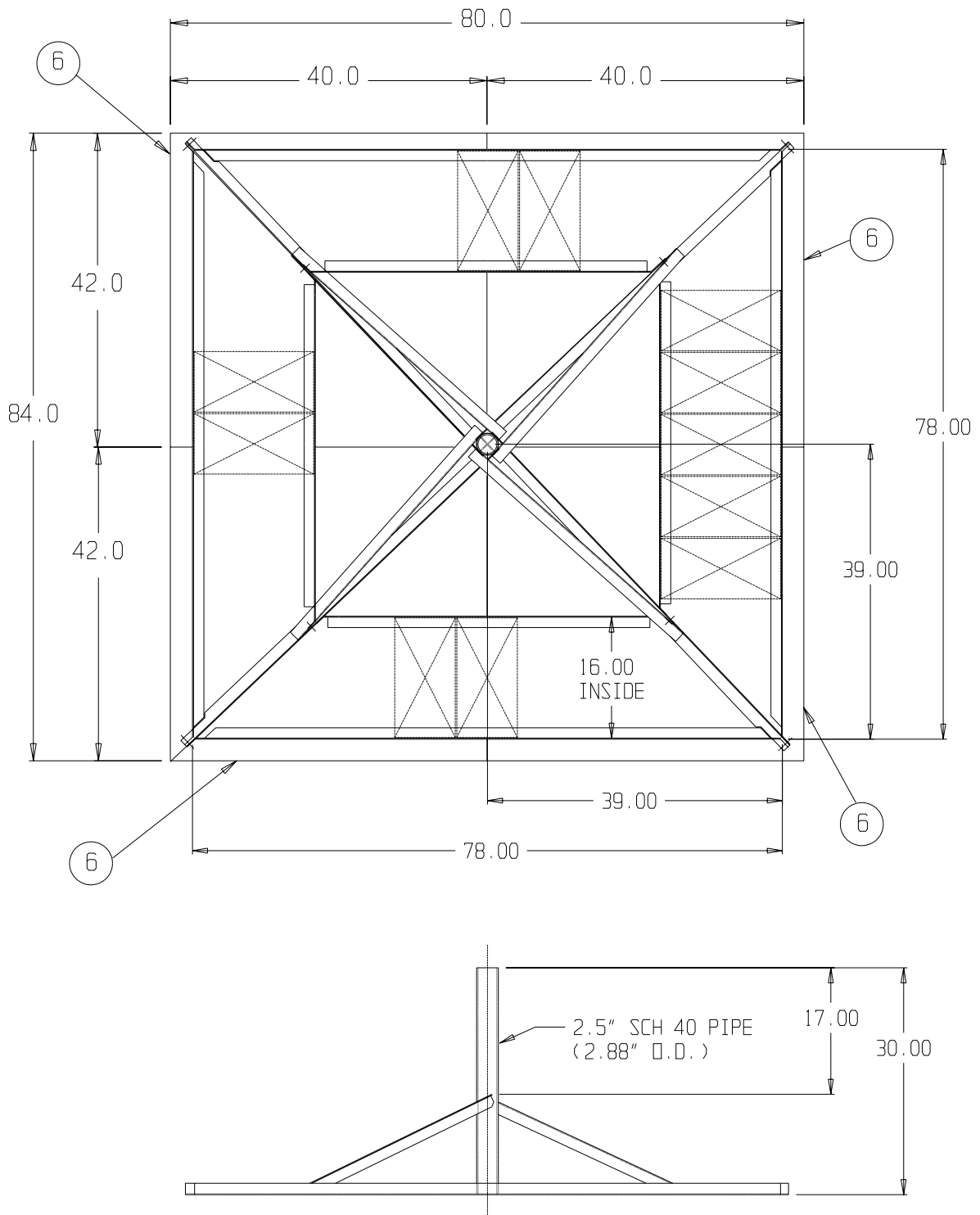
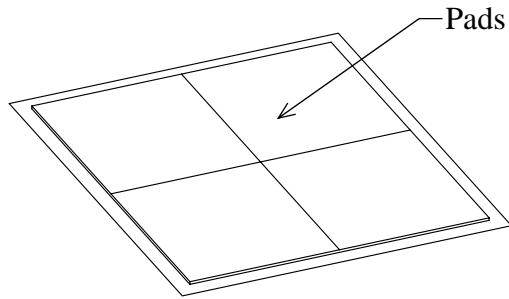

Figure 2

SECTION II

ASSEMBLY INSTRUCTIONS



STEP 1:

- A). Locate site of installation and clear an area of 7 x 7 square feet of all debris.
- B). Place rubber pads (item 6) within the cleared area to form a square.
(See Figure 2)

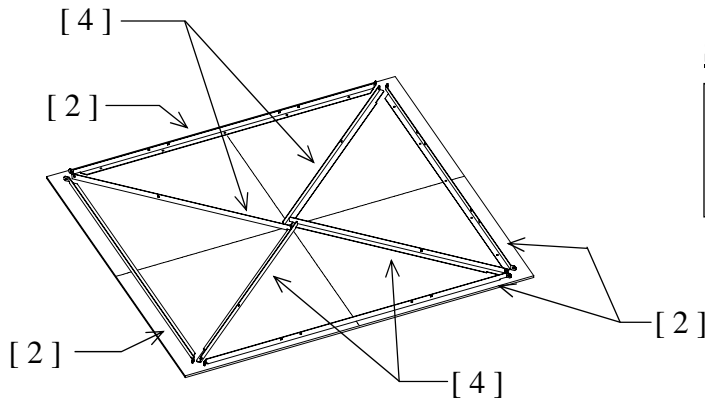

STEP 2:

- A). On the rubber pad, layout the (4) outer base angles (item 2) and the (4) diagonal base angles (item 4).

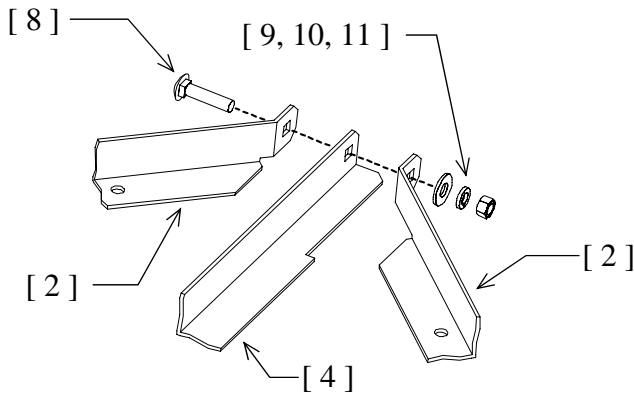

STEP 3:

- A). Attach the four outer corners as shown using 3 / 8" hardware (items 8,9,10 & 11) Snug only.

(Note the orientation of the angles)

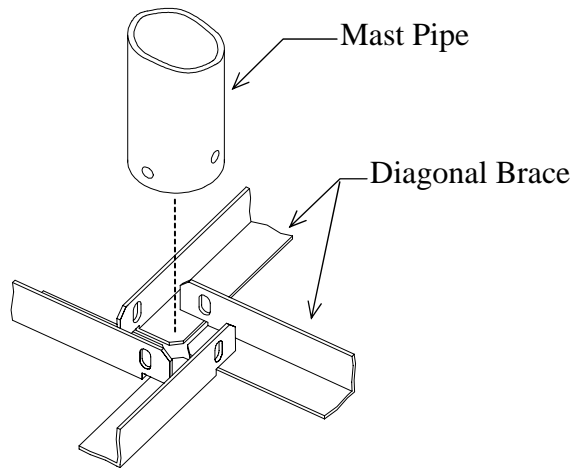

STEP 4:

A). Place the mast pipe (item 1) at the center of the diagonal braces and align holes.

(Note the orientation of diagonal braces)

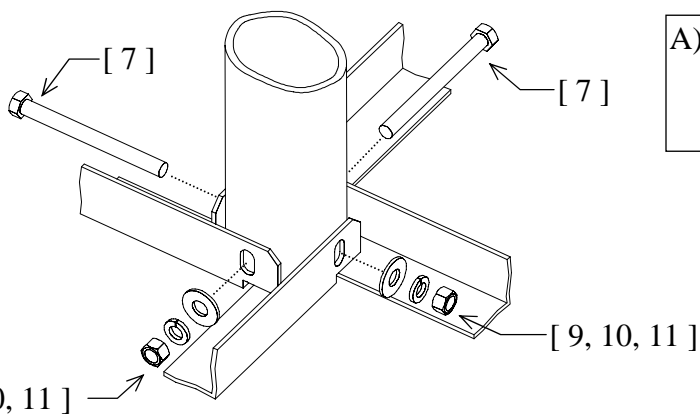

STEP 5:

A). Secure the mast pipe to the diagonal angles with 3 / 8" hardware (items 7, 9, 10, & 11). Snug only.

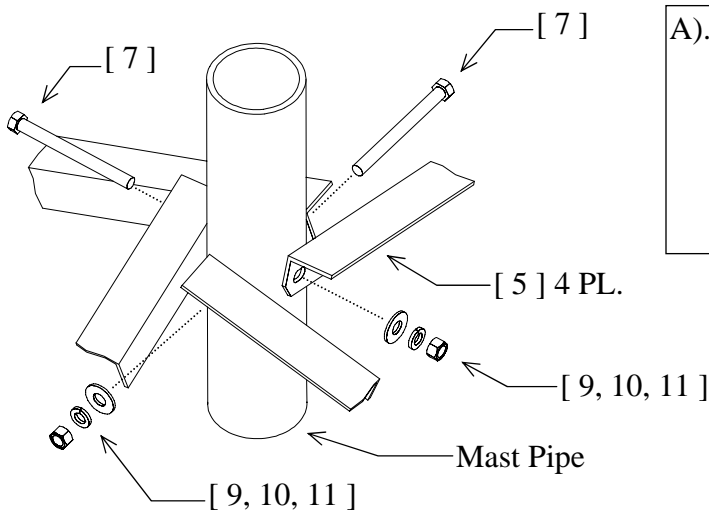

STEP 6:

A). Attach the (4) mast brace angles (item 5) to the mast pipe with 3 / 8" hardware (items 7, 9, 10 & 11). Each brace must attach to the side of the mast pipe opposite its corresponding diagonal brace. Refer figures 1 and 2. Snug only.

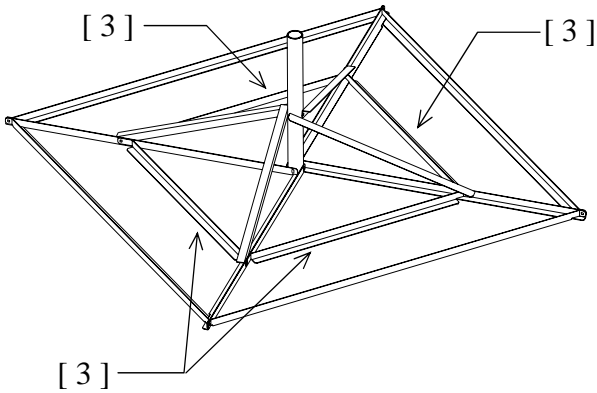

STEP 7:

A). Position the (4) inner brace angles (item 3) as shown. Use Step 8 below for reference to the angle orientation.

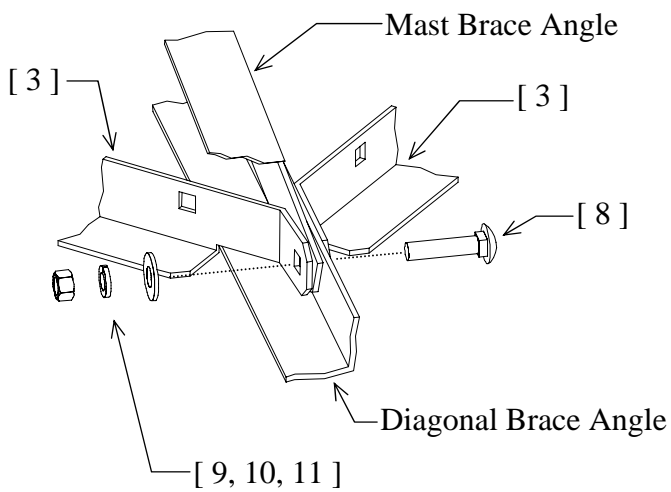

STEP 8:

- A). Attach the inner brace angle (item 3) to the mast brace angle and diagonal base angle with 3 / 8" hardware (items 8, 9, 10 & 11). Note the orientation of the angles.
- B). Tighten all hardware. The suggested torque is 20 ft-lbs dry or 15 ft-lbs lubricated.
- C). Add ballast and then install antenna system. See section 3 for the ballast requirements.

SECTION III

3.0 BALLAST REQUIREMENTS

EXPOSURE:

1. Exposure B is urban or suburban areas, wooded areas, or other terrain with numerous, closely spaced obstructions having the size of single family dwellings or larger. Obstructions must extend 1500 feet in all directions from the antenna.
2. Exposure C is open terrain with widely scattered obstructions having heights generally less than 30 feet. Includes flat open country and grass lands.

BALLAST:

1. Ballast tables are based on an overturning design with a 1.5 safety factor. Values shown provide sliding resistance to the wind speed shown with a 1.0 safety factor when used with a rubber friction pad (coefficient of friction = .64).
2. Recommended ballast material is concrete cap block, nominal dimensions of 4 x 8 x 16 inches. These blocks will weigh between 25 and 30 lbs each, depending on local variation. Average weight of blocks should be determined for correct ballast amount.
3. Place ballast equally on all frames beginning at opposite corners of each side and working inward. If more than 20 blocks are needed, begin a second layer on top of the first.

**TABLE 3.0-1 - 1.0M OR SMALLER SHAPED VSAT ANTENNA
BALLAST REQUIREMENTS - EXPOSURE B - 30 FT. ABOVE GROUND**

WIND SPEED (M.P.H.)	70	80	90	100	110	125
TOTAL BALLAST (LBS.)	235	285	385	460	560	710
STATIC ROOF LOAD (LB./FT.2)	6	7	9	11	13	17
ANTENNA & NPMM WT. (LBS.)	160	160	160	160	160	160
NET BALLAST REQUIRED (LBS.)	75	125	225	300	400	550

**TABLE 3.0-2 - 1.0M OR SMALLER SHAPED VSAT ANTENNA
BALLAST REQUIREMENTS - EXPOSURE B - 50 FT. ABOVE GROUND**

WIND SPEED (M.P.H.)	70	80	90	100	110	125
TOTAL BALLAST (LBS.)	260	335	410	535	610	785
STATIC ROOF LOAD (LB./FT.2)	6	8	10	12	14	19
ANTENNA & NPMM WT. (LBS.)	160	160	160	160	160	160
NET BALLAST REQUIRED (LBS.)	100	175	250	375	450	625

**TABLE 3.0-3 - 1.0M OR SMALLER SHAPED VSAT ANTENNA
BALLAST REQUIREMENTS - EXPOSURE C - 30 FT. ABOVE GROUND**

WIND SPEED (M.P.H.)	70	80	90	100	110	125
TOTAL BALLAST (LBS.)	335	435	560	685	885	1060
STATIC ROOF LOAD (LB./FT.2)	8	10	13	16	21	25
ANTENNA & NPMM WT. (LBS.)	160	160	160	160	160	160
NET BALLAST REQUIRED (LBS.)	175	275	400	525	725	900

**TABLE 3.0-4 - 1.0M OR SMALLER SHAPED VSAT ANTENNA
BALLAST REQUIREMENTS - EXPOSURE C - 50 FT. ABOVE GROUND**

WIND SPEED (M.P.H.)	70	80	90	100	110	125
TOTAL BALLAST (LBS.)	410	510	635	810	935	1210
STATIC ROOF LOAD (LB./FT.2)	10	12	15	19	22	29
ANTENNA & NPMM WT. (LBS.)	160	160	160	160	160	160
NET BALLAST REQUIRED (LBS.)	250	350	475	650	775	1050

**TABLE 3.0-5 - 1.2M CIRCULAR VSAT ANTENNA
BALLAST REQUIREMENTS - EXPOSURE B - 30 FT. ABOVE GROUND**

WIND SPEED (M.P.H.)	70	80	90	100	110	125
TOTAL BALLAST (LBS.)	365	465	615	715	890	1140
STATIC ROOF LOAD (LB./FT.2)	9	11	15	17	21	27
ANTENNA & NPMM WT. (LBS.)	165	165	165	165	165	165
NET BALLAST REQUIRED (LBS.)	200	300	450	550	725	975

**TABLE 3.0-6 - 1.2M CIRCULAR VSAT ANTENNA
BALLAST REQUIREMENTS - EXPOSURE B - 50 FT. ABOVE GROUND**

WIND SPEED (M.P.H.)	70	80	90	100	110	125
TOTAL BALLAST (LBS.)	415	540	690	840	1015	1290
STATIC ROOF LOAD (LB./FT.2)	10	13	16	20	24	31
ANTENNA & NPMM WT. (LBS.)	165	165	165	165	165	165
NET BALLAST REQUIRED (LBS.)	250	375	525	675	850	1125

**TABLE 3.0-7 - 1.2M CIRCULAR VSAT ANTENNA
BALLAST REQUIREMENTS - EXPOSURE C - 30 FT. ABOVE GROUND**

WIND SPEED (M.P.H.)	70	80	90	100	110	125
TOTAL BALLAST (LBS.)	540	740	890	1115	1315	1690
STATIC ROOF LOAD (LB./FT.2)	13	18	21	26	31	40
ANTENNA & NPMM WT. (LBS.)	165	165	165	165	165	165
NET BALLAST REQUIRED (LBS.)	375	575	725	950	1150	1525

**TABLE 3.0-8 - 1.2M CIRCULAR VSAT ANTENNA
BALLAST REQUIREMENTS - EXPOSURE C - 50 FT. ABOVE GROUND**

WIND SPEED (M.P.H.)	70	80	90	100	110	125
TOTAL BALLAST (LBS.)	640	840	1065	1290	1515	1990
STATIC ROOF LOAD (LB./FT.2)	15	20	25	31	36	47
ANTENNA & NPMM WT. (LBS.)	165	165	165	165	165	165
NET BALLAST REQUIRED (LBS.)	475	675	900	1125	1350	1825

TABLE 3.0-9 - 1.0M OR SMALLER SHAPED VSAT ANTENNA
BALLAST REQUIREMENTS - EXPOSURE B - 9M ABOVE GROUND

WIND SPEED (K.P.H.)	113	129	145	161	177	201
TOTAL BALLAST (KG.)	107	129	175	209	254	322
STATIC ROOF LOAD (KG./M ²)	29	34	44	54	63	83
ANTENNA & NPMM WT. (KG.)	73	73	73	73	73	73
NET BALLAST REQUIRED (KG.)	34	57	102	136	181	249

TABLE 3.0-10 - 1.0M OR SMALLER SHAPED VSAT ANTENNA
BALLAST REQUIREMENTS - EXPOSURE B - 15M. ABOVE GROUND

WIND SPEED (K.P.H.)	113	129	145	161	177	201
TOTAL BALLAST (KG.)	118	152	186	243	277	356
STATIC ROOF LOAD (KG./M ²)	29	39	49	58	68	93
ANTENNA & NPMM WT. (KG.)	73	73	73	73	73	73
NET BALLAST REQUIRED (KG.)	45	79	113	170	204	284

TABLE 3.0-11 - 1.0M OR SMALLER SHAPED VSAT ANTENNA
BALLAST REQUIREMENTS - EXPOSURE C - 9M. ABOVE GROUND

WIND SPEED (K.P.H.)	113	129	145	161	177	201
TOTAL BALLAST (KG.)	152	197	254	311	401	481
STATIC ROOF LOAD (KG./M ²)	39	49	63	78	102	122
ANTENNA & NPMM WT. (KG)	73	73	73	73	73	73
NET BALLAST REQUIRED (KG)	79	125	181	238	329	408

TABLE 3.0-12 - 1.0M OR SMALLER SHAPED VSAT ANTENNA
BALLAST REQUIREMENTS - EXPOSURE C - 15M ABOVE GROUND

WIND SPEED (K.P.H.)	113	129	145	161	177	201
TOTAL BALLAST (KG)	186	231	288	367	424	549
STATIC ROOF LOAD (KG./M ²)	49	58	73	93	107	141
ANTENNA & NPMM WT. (KG)	73	73	73	73	73	73
NET BALLAST REQUIRED (KG)	113	159	215	295	352	478

TABLE 3.0-13 - 1.2M CIRCULAR VSAT ANTENNA
BALLAST REQUIREMENTS - EXPOSURE B - 9M ABOVE GROUND

WIND SPEED (K.P.H.)	113	129	145	161	177	201
TOTAL BALLAST (KG.)	166	211	279	324	404	517
STATIC ROOF LOAD (KG./M ²)	44	54	73	83	102	132
ANTENNA & NPMM WT. (KG.)	75	75	75	75	75	75
NET BALLAST REQUIRED (KG.)	91	136	204	249	329	442

TABLE 3.0-14 - 1.2M CIRCULAR VSAT ANTENNA
BALLAST REQUIREMENTS - EXPOSURE B - 15M ABOVE GROUND

WIND SPEED (K.P.H.)	113	129	145	161	177	201
TOTAL BALLAST (KG.)	188	245	313	381	460	585
STATIC ROOF LOAD (KG./M ²)	49	63	78	97	117	151
ANTENNA & NPMM WT. (KG.)	75	75	75	75	75	75
NET BALLAST REQUIRED (KG.)	113	170	238	306	386	510

TABLE 3.0-15 - 1.2M CIRCULAR VSAT ANTENNA
BALLAST REQUIREMENTS - EXPOSURE C - 9M ABOVE GROUND

WIND SPEED (K.P.H.)	113	129	145	161	177	201
TOTAL BALLAST (KG.)	245	336	404	506	596	767
STATIC ROOF LOAD (KG./M ²)	63	88	102	127	151	195
ANTENNA & NPMM WT. (KG.)	75	75	75	75	75	75
NET BALLAST REQUIRED (KG.)	170	261	329	431	522	692

TABLE 3.0-16 - 1.2M CIRCULAR VSAT ANTENNA
BALLAST REQUIREMENTS - EXPOSURE C - 15M ABOVE GROUND

WIND SPEED (K.P.H.)	113	129	145	161	177	201
TOTAL BALLAST (KG.)	290	381	483	585	687	903
STATIC ROOF LOAD (KG./M ²)	73	97	122	151	175	229
ANTENNA & NPMM WT. (KG.)	75	75	75	75	75	75
NET BALLAST REQUIRED (KG.)	215	306	408	510	612	828

3.1 **BALLAST REQUIREMENT INFORMATION**

- 3.1-1. Ballast requirements are provided to assist in determining the applicability of the NPMM for an antenna installation. The ballast data should not be relied upon without competent local professional examination and verification of its accuracy and suitability for a specific site or application.
- 3.1-2. Specific antenna types may require more strength and ballast requirements and must be investigated for each installation. The load carrying requirements of the supporting surface, the mast, the antenna and the antenna's connection to the mast must also be investigated for each installation.
- 3.1-3. Roof pads are recommended to prevent damage to roof membranes. Pads should be placed under all ballast and under the mast pipe. When roof pads are utilized, the minimum coefficient of friction between the ballast pans and roof pad or between the roof pads and the supporting surface must be used to calculate the wind speeds resulting in sliding.
- 3.1-4. When adhesive, sealant or pads are utilized, they must be compatible with the supporting surface. They must also be durable and have adequate strength. Precautions should also be taken to insure that damage to the supporting surface will not occur upon wind loading. Adhesives and sealants must be capable of resisting shear; otherwise, they may act as a lubricant and decrease the effective coefficient of friction between the ballast and the supporting structure.
- 3.1-5. The installation, roof materials and supporting structure must be capable of withstanding all loads imposed by the antenna system. Supporting structure, anchors and/or safety cables must be sufficient to resist the reactions from the antenna system. The installation must meet all applicable, local, state and federal requirements. ***Due to the many variables involved, General Dynamics does not accept responsibility for verifying the applicability of the NPMM for specific installation.***