

**GENERAL DYNAMICS**  
SATCOM Technologies

**4096-224**  
**REVISION H**  
**May 13, 2009**

**ASSEMBLY MANUAL**

**1.8 METER**  
**SERIES 1184 ANTENNA SYSTEM**

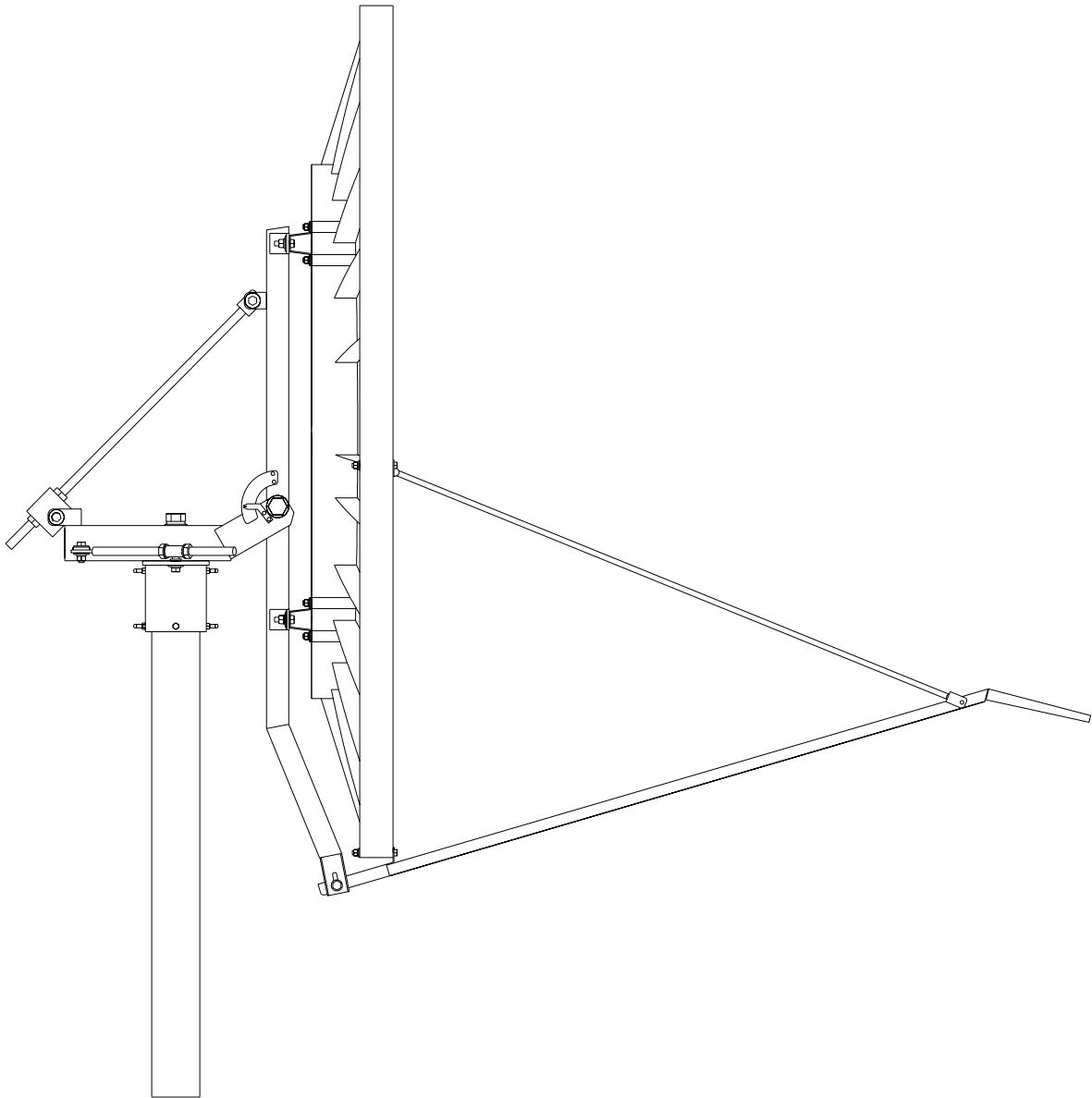
**General Dynamics SATCOM Technologies**  
**1500 Prodelin Drive**  
**Newton NC 28658**

# 1.8 METER SERIES 1184 ANTENNA SYSTEM

REV.	DESCRIPTION	DATE	APPROVED
H	Revised Tool/Torque Table	5/13/09	RAH
G	Revise Logo	4/16/09	RAH
F	Revised Address	1/10/02	RAH
E	Revise HDWE list page 9	11/6/00	RAH
D	Update	6/10/97	PGW
C	Revised parts list table to reflect B.O.M	1/29/97	PGW
B	Added revision page	3/10/93	R.F.

**1.8M SERIES 1184 ANTENNA SYSTEM****TABLE OF CONTENTS**

<b><u>SECTION</u></b>	<b><u>TITLE</u></b>
<b>I</b>	<b>GENERAL INFORMATION</b>
1.0	Introduction
1.1	Unpacking And Inspection
1.2	Freight Damage
1.3	Missing Or Damaged Material
1.4	Suggested Tool List
1.5	Mechanical Alignment Tools
1.6	Suggested Mast & Foundation
<b>II</b>	<b>ANTENNA SYSTEM</b>
2.0	Assembly Procedure
<b>III</b>	<b>FEED SUPPORT</b>
3.0	Feed Support Installation
<b>IV</b>	<b>ANTENNA POINTING</b>
4.0	Alignment To Satellite
4.1	Initial Alignment
<b>V</b>	<b>MAINTENANCE</b>
5.0	Maintenance Overview
5.1	Periodic Inspection
5.2	Reflector
5.3	Mount And Reflector Support
5.4	Feed And Feed Support



**SECTION I**            **GENERAL INFORMATION****1.0**    **Introduction**

This manual describes the assembly and installation of General Dynamics's 1.8M Rx/Tx offset antenna system with an Az/EI mount (series number 1184). The General Dynamics 1.8M is a rugged, reliable antenna system, which will operate in the 11.7 to 12.2 and 14.0 to 14.5 GHz frequency bands for Ku-Band systems and 3.7 to 4.2 and 5.925 to 6.425 GHz frequency bands for C-Band systems with high efficiency and at the same time successfully withstand the effects of the environment.

These instructions are listed by sections that cover all areas of assembly and installation. Additional sections are included in the manual to provide information on antenna alignment to the satellite and maintenance.

**1.1**    **Unpacking And Inspection**

The antenna containers should be unpacked and inspected at the earliest date to ensure that all material has been received and is in good condition. A complete packing list for each major component is supplied.

**1.2**    **Freight Damage**

Any damage to materials while in transit should be immediately directed to the freight carrier. He will instruct you on matters regarding any freight damage claims.

**1.3**    **Material - Missing Or Damaged**

Any questions regarding missing or damaged materials that is not due to the freight carrier should be directed to General Dynamics's Customer Service Department at:

**General Dynamics SATCOM Technologies**  
**1500 Prodelin Drive**  
**Newton NC 28658**  
**USA**  
**(828) 464-4141**

**1.4 Suggested Tool List**

The following tools are suggested for the antenna installation.

HARDWARE SIZE	SAE WRENCH SIZE	METRIC WRENCH SIZE	MAXIMUM REC. TORQUE
#10 SCREW	5/16"	7 mm	FLATTEN LOCK WASHERS
5/16" BOLT	1/2"	13 mm	12 ft-lbs (1.66 kg-m)
3/8" BOLT	9/16"	14 mm	20 ft-lbs (2.80 kg-m)
1/2" BOLT	3/4"	20 mm	45 ft-lbs (6.20 kg-m)
3/4" NUT	1-1/8"	28 mm	145 ft-lbs (22.07 kg-m)
1" BOLT	1-1/2"	38 mm	220 ft-lbs (30.34 kg-m)

**NOTE:** The Minimum Torque applied should not be less than 10% of maximum required torque listed in the table.

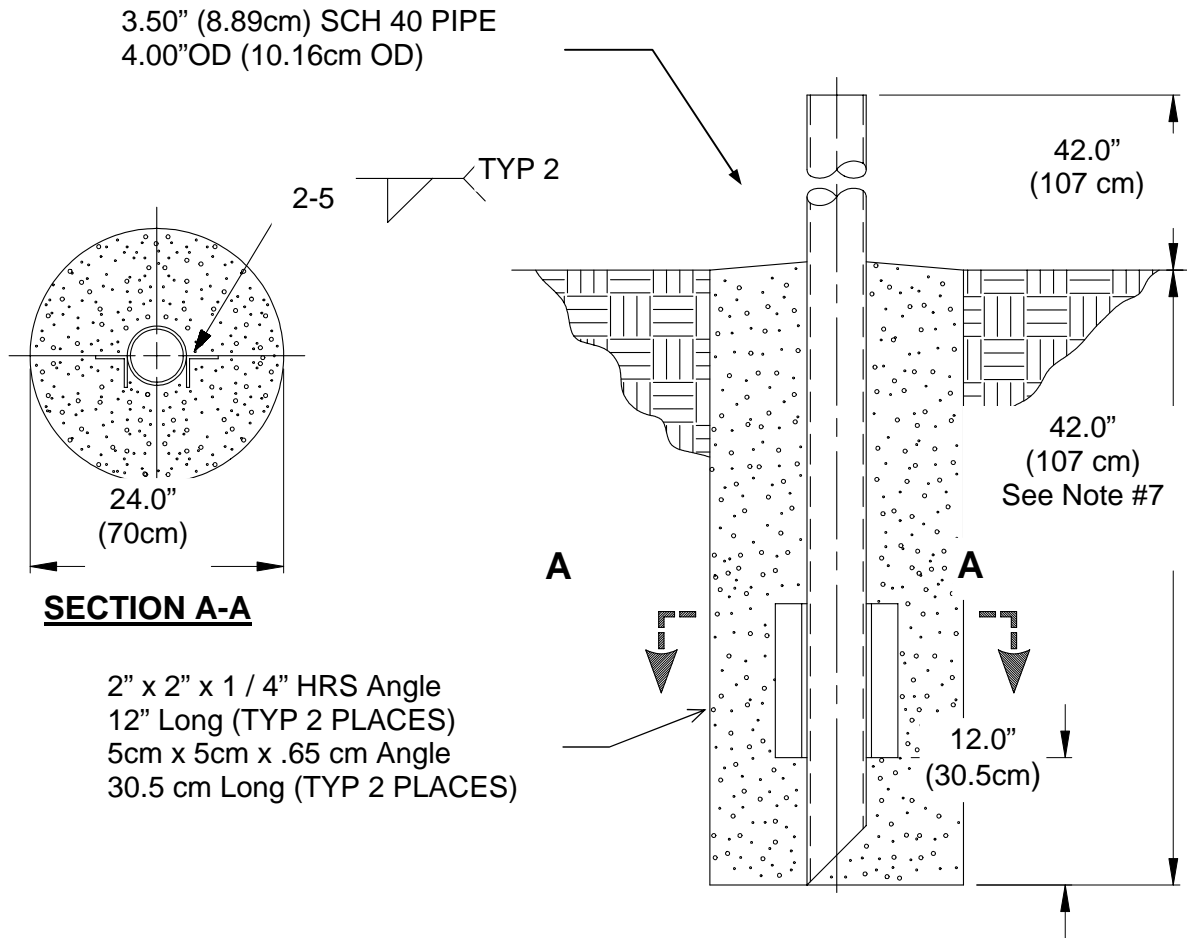
**1.5 Mechanical Alignment Tools**

The following tools are suggested for the initial alignment to the satellite.

- 1) COMPASS
- 2) INCLINOMETER
- 3) 10" CRESCENT WRENCH
- 4) SCREWDRIVER, STANDARD BLADE

**1.6 Suggested Mast & Foundation**

The required interface from the foundation to the mount is 3.5" schedule 40 pipe (4.0" or 10.16 cm O.D.). A suggested in-ground foundation is shown in Figure 1.

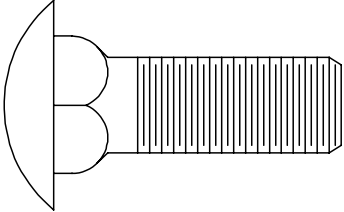
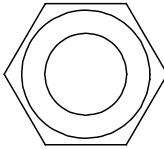
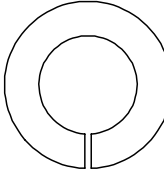
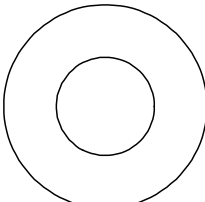


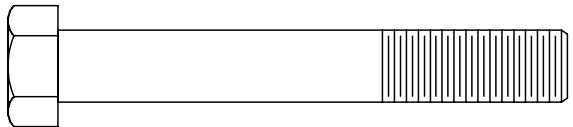
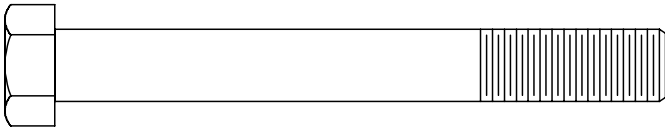
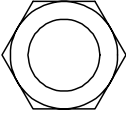
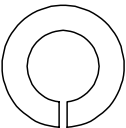
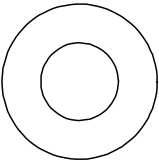
**FIGURE 1.**

**NOTES:**

1. 2 x 2 x 1/4 HRS Angle and schedule 40 pipe should conform with ASTM A36 and ASTM A53 Type E and S Grade B.
  2. All concrete should conform to building code standards and have a minimum compressive strength of 3000 PSI at 28 days. (Per ACI-318-77)
  3. Soil bearing capacity should be no less than 2000 PSF.
  4. Concrete should be poured against undisturbed soil.
  5. Allow concrete 24 hours set time before installation of antenna.
  6. The antenna should be properly grounded to meet applicable local codes.
  7. Minimum depth as shown or extend to local frost line.
  8. Foundation meets the design requirements as set forth by the uniform building code. (1982 edition)
- (GENERAL DYNAMICS DOES NOT REPRESENT OR WARRANT THAT ANY PARTICULAR DESIGN OR SIZE OF FOUNDATION IS APPROPRIATE FOR ANY LOCALITY OR EARTH STATION INSTALLATION.)**

**SECTION II**      **ANTENNA ASSEMBLY**

<b>PARTS LIST - 1.8M ANTENNA ASSEMBLY</b>			
<b>ITEM</b>	<b>PART NO.</b>	<b>DESCRIPTION</b>	<b>QTY</b>
1	VARIES	1.8M REFLECTOR	1
2	0181-276	AZ/EL POSITIONER ASSEMBLY	1
3	0181-246	REFLECTOR SUPPORT TUBE	1
4	0211-417	REFLECTOR CROSS ARMS	2
5	0159-220	#10 SPACER	2
6	0156-572	ELEVATION MARKING PLATE	1
7	0211-497	ELEVATION POINTER	1
8	8043-014	1 / 2" x 1.50" CARRIAGE BOLT	4
			
9	8104-007	1 / 2" HEX NUT	4
			
10	8202-043	1 / 2" LOCK WASHER	4
			
11	8201-043	1 / 2" WASHER	4
			

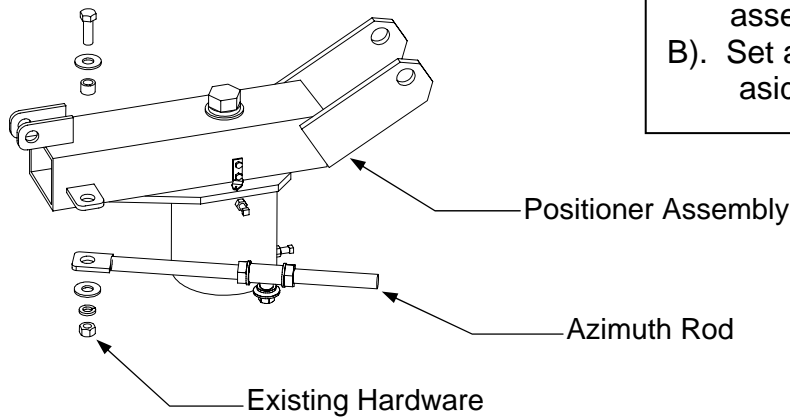
PARTS LIST - CONTINUED			
ITEM	PART NO.	DESCRIPTION	QTY
12	8032-036	3 / 8" x 4.5" HEX BOLT 	4
13	8032-040	3 / 8" x 5.0" HEX BOLT 	4
14	8102-007	3 / 8" HEX NUT 	8
15	8202-042	3 / 8" LOCK WASHER 	8
16	8201-042	3 / 8" WASHER 	8

**CAUTION:** During the assembly procedure, the sequence of instructions must be followed. DO NOT TIGHTEN ANY HARDWARE UNTIL INSTRUCTED.

## 2.0 Assembly Overview

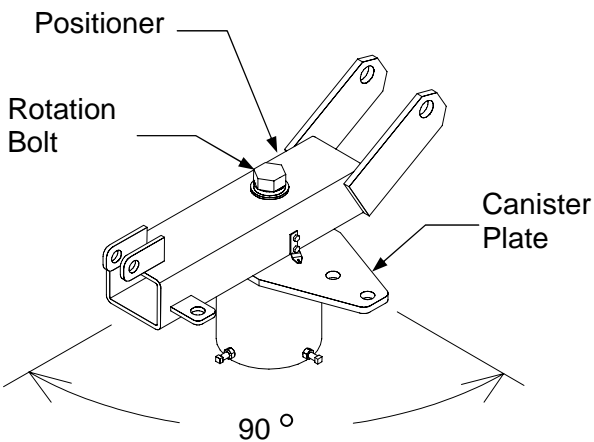
### STEP 1:

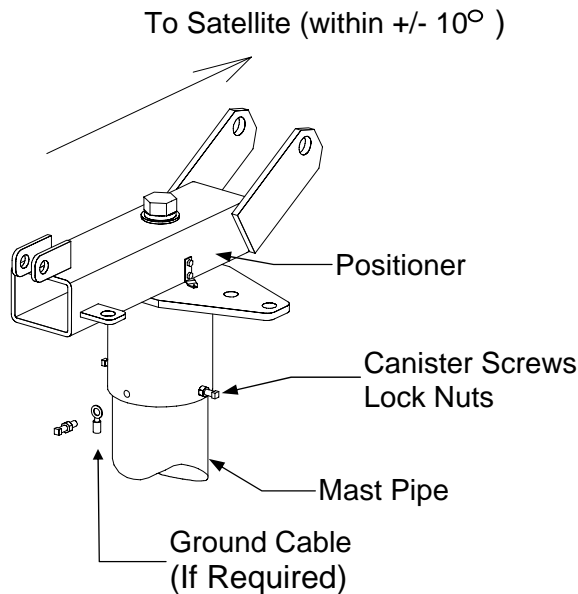
- A). Remove azimuth rod from positioner assembly.
- B). Set azimuth rod and related hardware aside.



### STEP 2:

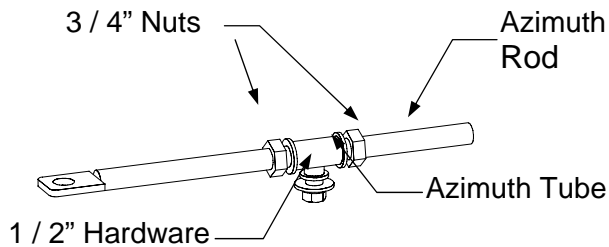
- A). Loosen rotation bolt on top of positioner.
- B). Rotate the positioner so that the canister plate is oriented as shown.





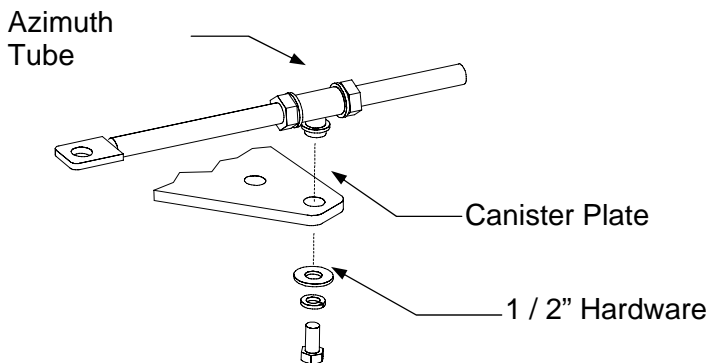
**STEP 3:**

- A). Place positioner assembly onto mast pipe.
- B). Orient the positioner assembly approximately towards the center of the satellite orbital arc to within  $\pm 10^\circ$  as shown.
- C). Securely tighten [8] canister screws. Note: A grounding cable (if required) can be attached to any of the canister screws.
- D). Tighten [8] lock nuts against canister.



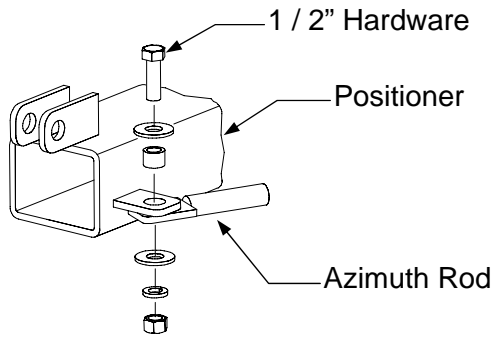
**STEP 4:**

- A). Locate azimuth rod (step 1.) and loosen the 3/4" nuts to allow movement of the azimuth tube.
- B). Remove 1/2" hardware from azimuth tube and set aside.



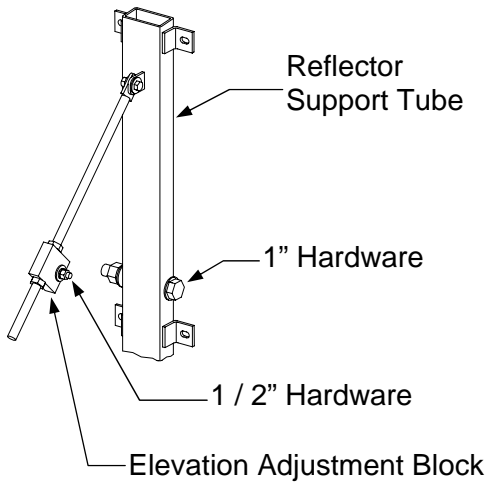
**STEP 5:**

- A). Locate end hole on canister plate.
- B). Position azimuth tube in hole and secure with 1/2" hardware from step 4.



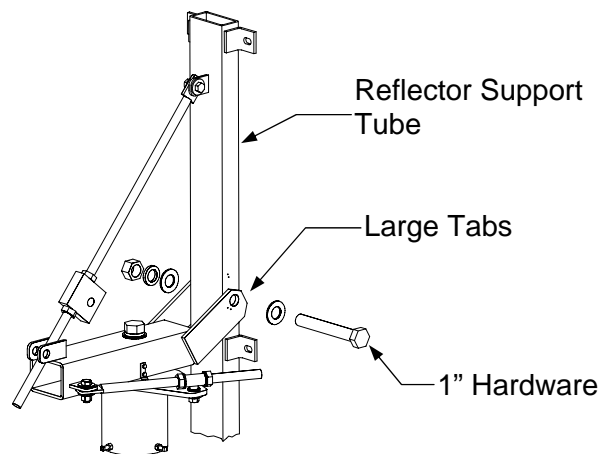
**STEP 6:**

- A). Rotate azimuth rod or the positioner so that the hole in the azimuth rod and the hole in the tab on the side of the positioner are lined up.
- B). Secure the azimuth rod to the positioner with the 1 / 2" hardware removed in step 1.
- C). Lightly tighten all of the azimuth adjustment hardware at this time.



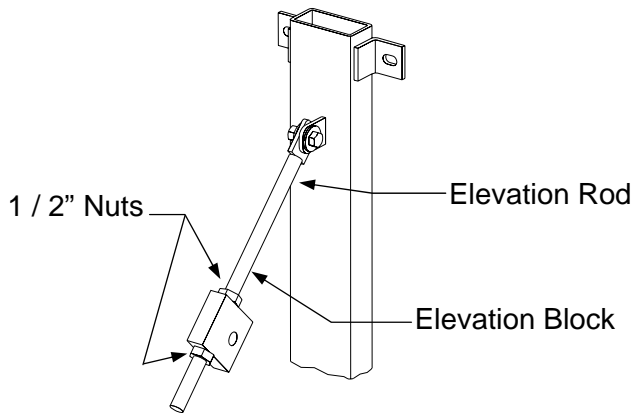
**STEP 7:**

- A). Remove 1" hardware from the reflector support tube.
- B). Remove 1 / 2" hardware from the elevation adjustment block and set aside.



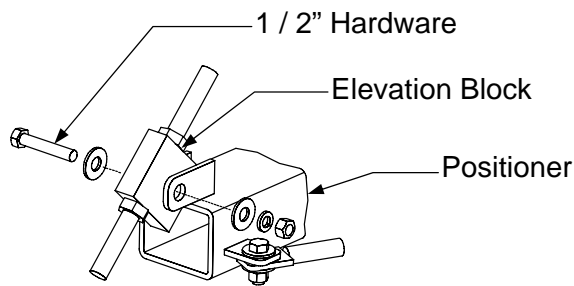
**STEP 8:**

- A). Place the reflector support tube in between the large tabs on the positioner as shown.
- B). Line up the holes on the tabs with the holes in the reflector support tube.
- C). Secure the support tube to the positioner with the 1" hardware.



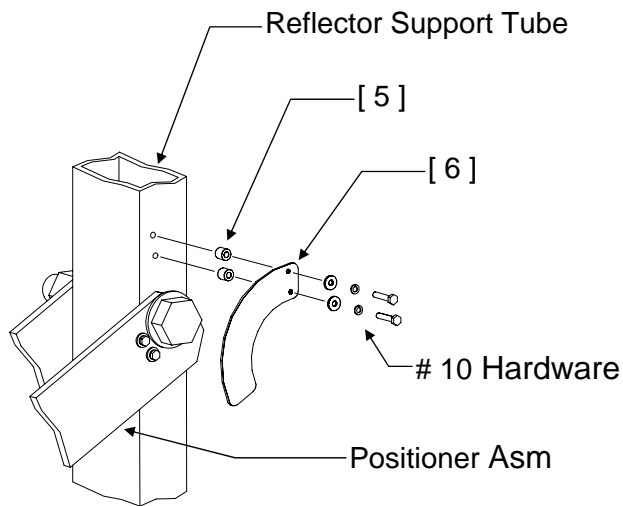
**STEP 9:**

- A). Loosen 1 / 2" nuts on elevation rod to allow movement of the elevation block.
- B). Slide elevation block down the elevation rod and position the block in between the small tabs on the positioner so that the holes in both block and tabs are aligned.



**STEP 10:**

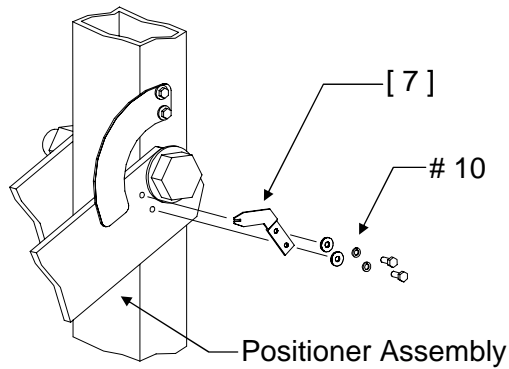
- A). Secure elevation block to positioner with 1 / 2" hardware set aside in step 7



**STEP 11:**

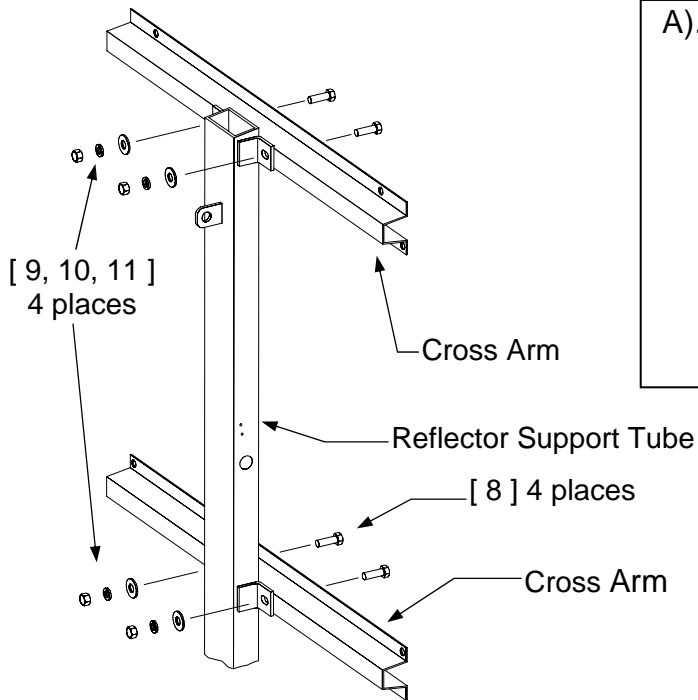
- A). Remove (2) #10 screws and washers from reflector support tube.
- B). Attach elevation marking plate (item 6) to support tube as shown with spacers (item 5) and #10 hardware. Note placement of spacers (item 5).
- C). Tighten only until lockwashers are flattened.

**STEP 12:**

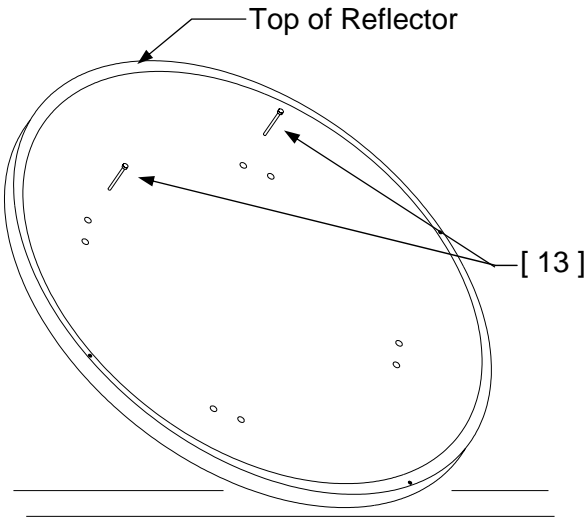


- A). Remove (2) #10 screws and washers from positioner assembly tab.
- B). Attach elevation pointer (item 7) to tab as shown with # 10 hardware.
- C). Tighten only until lockwashers are flattened.

**STEP 13:**

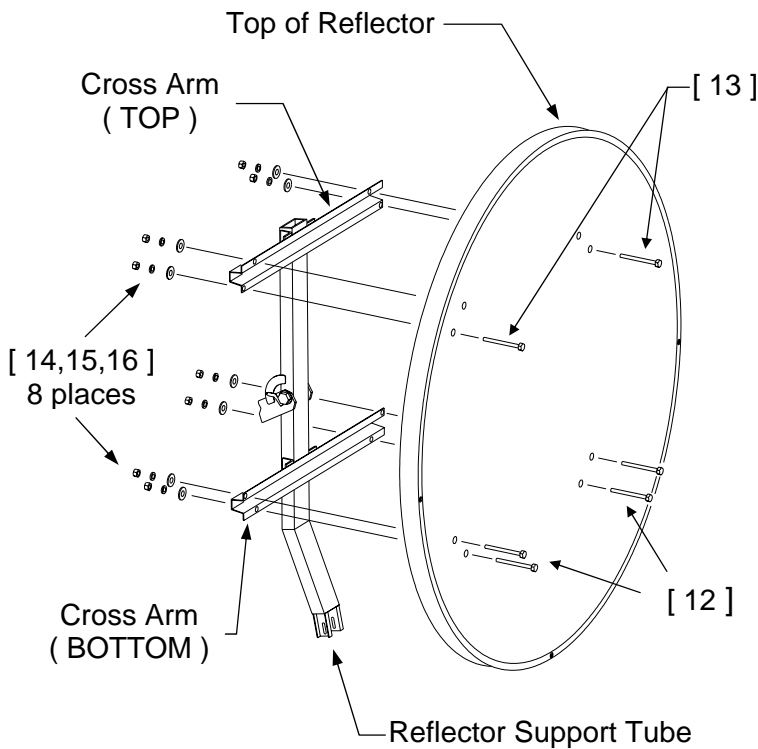


- A). Attach reflector cross arms to the reflector support tube with 1 / 2" hardware ( items: 8,9,10,11). Do not tighten.
- Note the orientation of reflector mounting holes, the inner most holes on the cross arm flanges will be to the top and the bottom of the reflector.



**STEP 14:**

- A). Locate the top of the reflector and insert (2) 5" bolts ( item 13 ) thru top two inner most holes on face of reflector as shown.

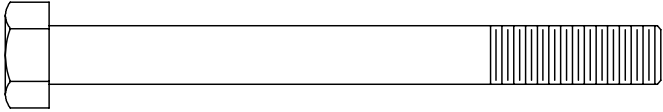
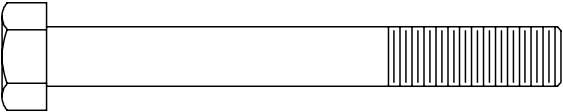
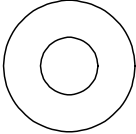
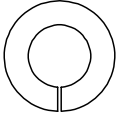
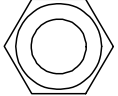
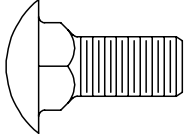


**STEP 15:**

- A). With a person on each side of the reflector, lift the reflector up.
- B). Position the reflector so that the (2) bolts (step 14) pass thru the two inner holes in the top cross arm.
- C). Loosely attach 3/8 " hardware (items,14,15,16). **Note:** the reflector is fully supported at this time.
- D). Insert the (2) remaining 5" bolts (item 13) thru the remaining two holes on top of reflector.
- E). Insert the (4) 4.5" bolts (item 12) thru the four bottom holes in reflector.
- F). Secure with (items 14, 15, 16).
- G). Using the torque specifications on page 6, tighten all reflector and mount hardware, with the exception of the 1 / 2" carriage bolts (they will be tightened in section III)

**SECTION III      FEED SUPPORT ASSEMBLY**

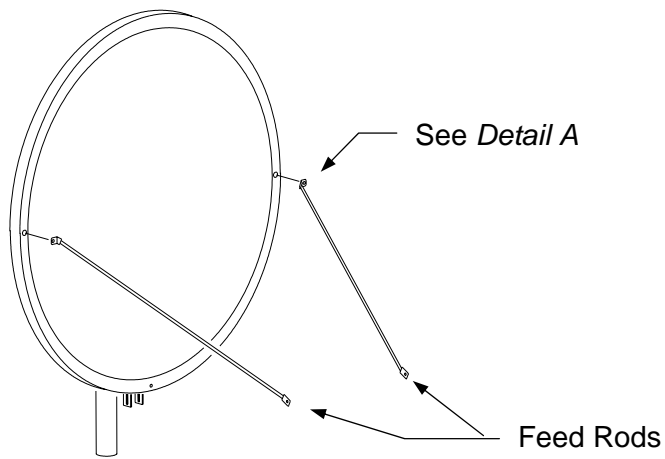
**These instructions are intended as a general reference for feed support assembly. If your antenna system has specific feed or feed support installation instructions, please refer to them at this time.**

<b>PARTS LIST - 1.8M FEED SUPPORT</b>			
<b>ITEM NO.</b>	<b>PART NO.</b>	<b>DESCRIPTION</b>	<b>QTY</b>
1	VARIES	Feed Rod	2
2	VARIES	Feed Support Tube	1
3	8031-030	5 / 16" x 3.75" Bolt 	3
4	8031-026	5 / 16" x 3.25" Bolt 	1
5	8201-041	5 / 16" Flatwasher 	10
6	8202-041	5 / 16" Lock Washer 	6
7	8101-009	5 / 16" Hex Nut 	6
8	8038-006	5 / 16" x .75" Carriage Bolt 	2

**CAUTION:** During the assembly procedure, the sequence of instructions must be followed. ***Do Not Tighten Any Hardware Until Instructed.*** Refer to the feed support parts list and the steps shown below.

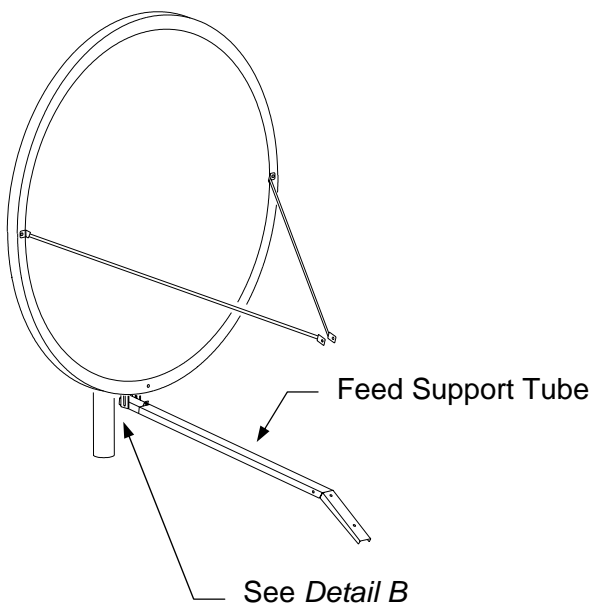
### **STEP 1:**

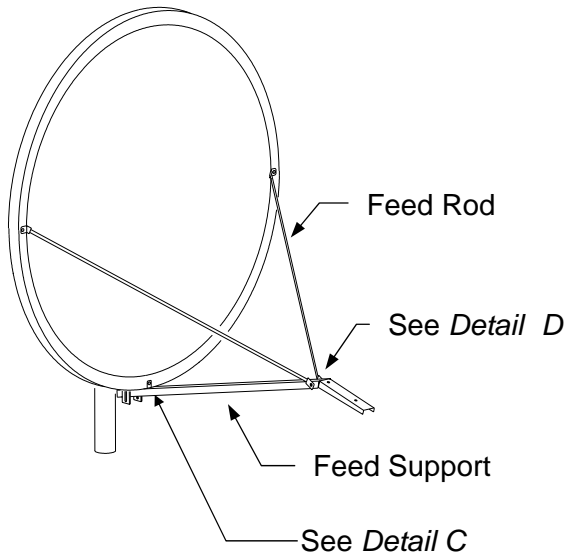
- A). Attach right and left feed rods to the reflector with (items 3, 6, 7) and with (2) of (item 5). See Figure 2 and Detail A.



### **STEP 2:**

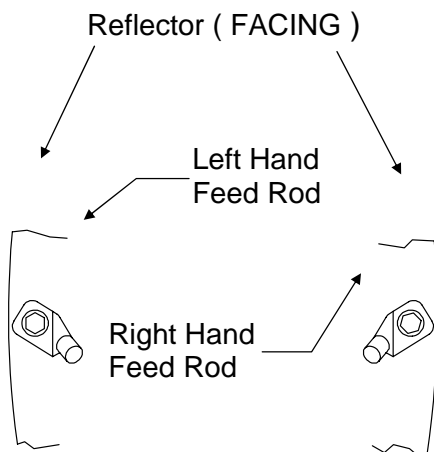
- A). Before attaching the feed support, sight the bottom of the reflector with the reflector support tube, to be sure the reflector is centered. If not, move the reflector left or right along the crossarms. See Figure 3.
- B). Loosely mount the bottom of the feed support to the reflector support tube with (2) of (items 8, 5, 6, 7). See Detail B.



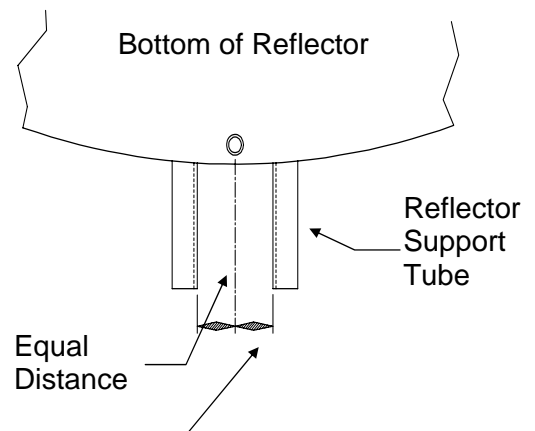


**STEP 3:**

- A). Attach feed support to the bottom of the reflector with ( items 3, 6, 7 ) and (2) of ( item 5 ). See Detail C.
- B). Connect the feed rods to the end of the feed support with (items 4, 6, 7) and (2) of ( item 5 ). See detail D
- C). Tighten the 1 / 2" carriage bolts to the reflector crossarms using the required torque specs on page 6.
- D). Tighten all feed assembly hardware using the required torque specs on page 6.

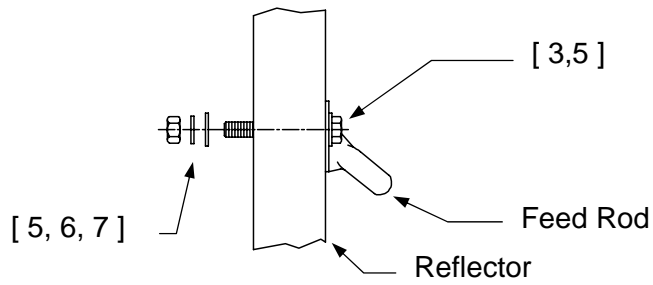


**FIGURE 2**

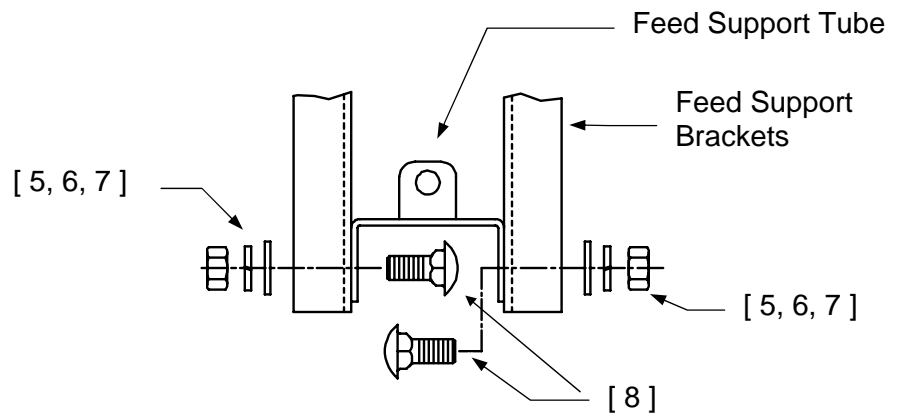


**FIGURE 3**

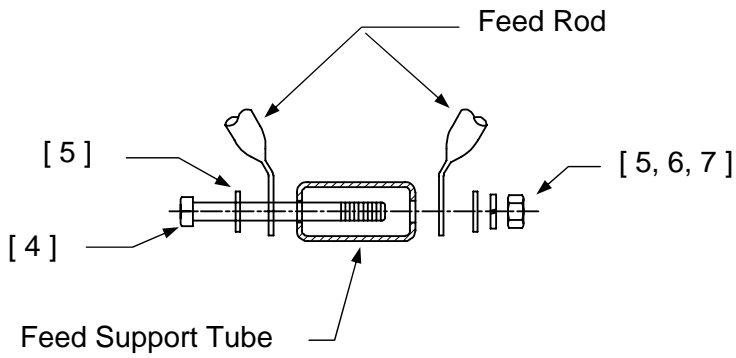
**DETAIL A**



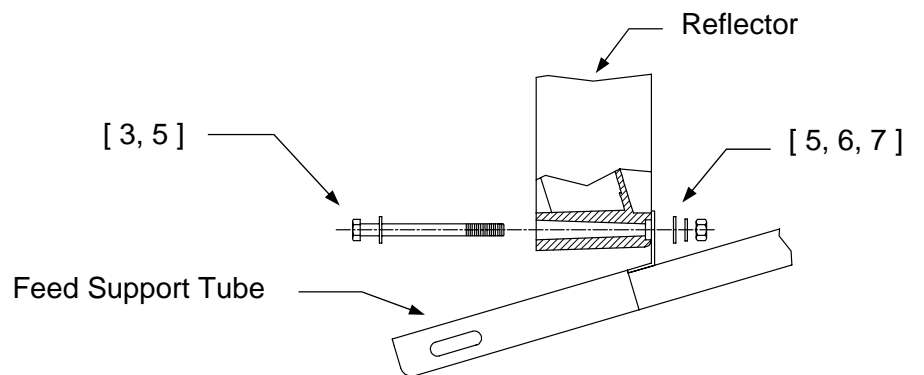
**DETAIL B**



**DETAIL D**



**DETAIL C**



## **SECTION IV**      **ANTENNA POINTING**

### **4.0 Alignment To Satellite**

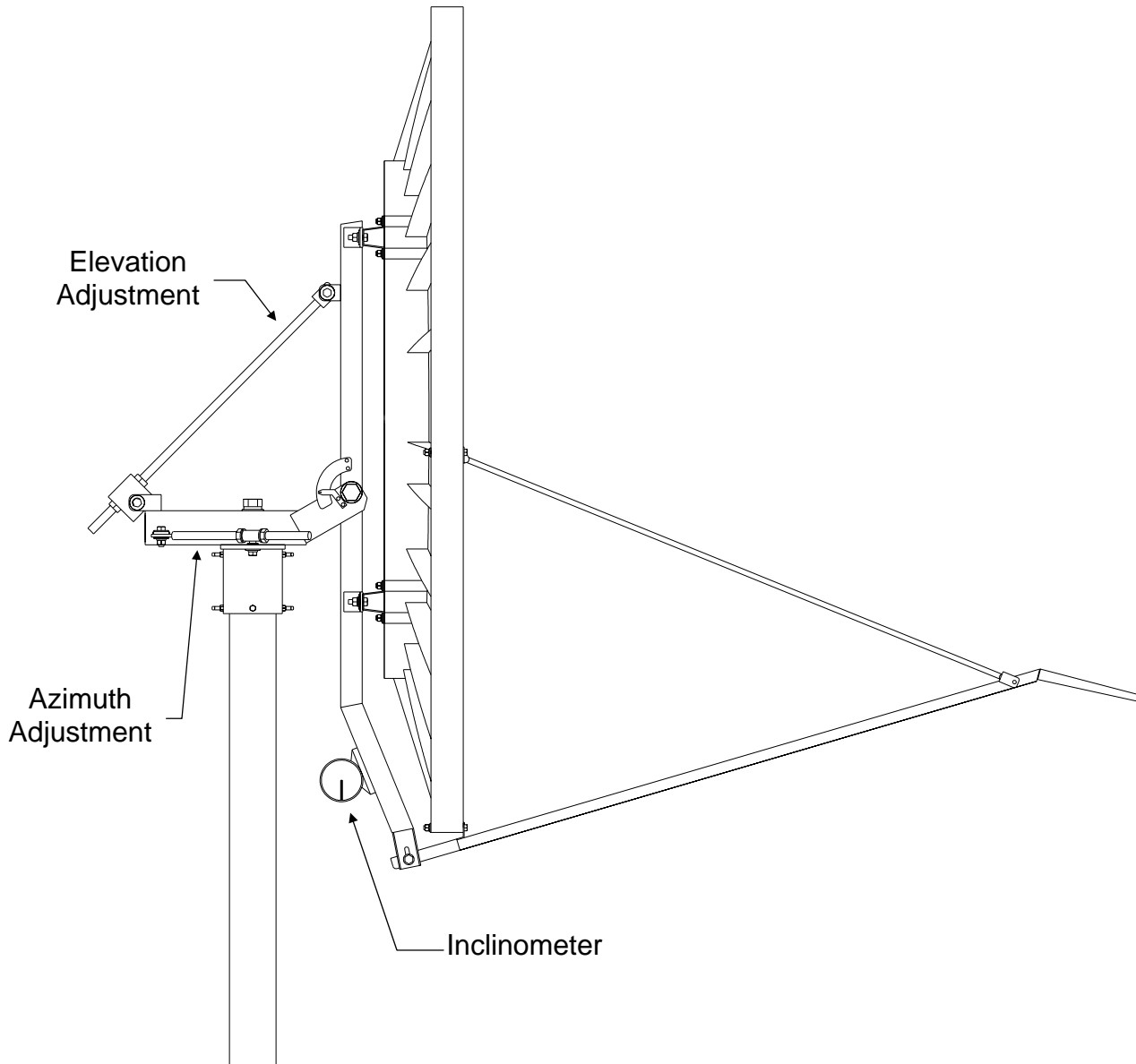
General Dynamics's 1.8 meter Az/EI mount requires that the antenna be aligned to the satellite orbital arc initially by a trained installer, after which, any future repointing to a second satellite can be accomplished quickly and easily by anyone with a minimum of tools and instruction.

### **4.1 Initial Alignment**

The 1.8 meter offset reflector contains a 22.3° elevation offset look angle. Therefore, when the reflector aperture is perpendicular to the ground, the antenna is actually looking 22.3° in elevation.

- 1) Aligning to primary satellite: Attach the inclinometer to the reflector support ring as shown in figure 4. This surface compensates for the 22.3° offset in the reflector, therefore a direct reading can be taken.
- 2) Raise or lower the antenna to find the desired elevation by turning the 3/4" nuts located at the elevation block. Position the top nut so that it will not interfere with adjustment. Turn the bottom nut clockwise to increase elevation and counterclockwise to decrease elevation.
- 3) After the correct elevation angle is set, rotate the antenna in azimuth by turning the 3/4" nuts located at the azimuth adjustment tube. Turn the front (near reflector) nut to decrease azimuth angle and the back nut to increase azimuth angle. Rotate azimuth until a signal is reached.
- 4) Peak the antenna signal by fine adjustments made in both azimuth and elevation.
- 5) Tighten the four (4) 3/4" nuts used for adjustments.
- 6) Mark satellite location: Locate the azimuth and elevation pointers, you will find a small hole in the end of the pointers, mark the canister plate and the elevation plate to identify the satellite location.
- 7) Aligning to secondary satellite: Loosen the 3/4" nuts on the azimuth adjustment rod, using the compass rotate the antenna in azimuth to the next satellite. Snug the 3/4" azimuth nuts at this time.

- 8) Loosen the 3/4" nuts on the elevation adjustment rod, place inclinometer on the angled reflector support tube, raise or lower the antenna to the new elevation. Snug the 3/4" elevation nuts at this time.
- 9) Peak the antenna signal by fine adjustments made in both azimuth and elevation.
- 10) Repeat step 6 for marking satellite location.
- 11) Return antenna to primary satellite by aligning azimuth and elevation pointers with the marks made in step #6. Tighten all adjustment hardware.



**FIGURE 4**

## **SECTION V**            **MAINTENANCE**

### **5.0**    **Maintenance Overview**

After installation, the antenna requires only periodic inspection. It is anticipated that maintenance, if required, will be minimal and easily handled by a local or in-house maintenance staff. The materials used in the construction of this Earth Station Antenna virtually eliminate any maintenance repairs.

### **5.1**    **Periodic Inspection**

It is suggested that a periodic inspection be performed at least every six months.

NOTE: After any very severe weather conditions, inspection of the antenna should be performed to determine if foreign objects have caused damage or if survival specifications have been exceeded.

This inspection should include the following:

- 1)    Check all bolting locations - all bolts should be tight.
- 2)    Check all structural members - repair or replace if damaged.
- 3)    Check the foundation anchor bolts - they must be secure and with no failure signs in foundation.
- 4)    Check for corrosion - on the reflector structure and mount.

### **5.2**    **Reflector**

General Dynamics's reflector does not require any maintenance. The composite construction of the reflector is virtually impervious to any damages that could be caused by weather or other atmospheric conditions.

It is only necessary to inspect for any physical damage done by vandalism or very severe weather conditions.

Should any damage be detected to a portion of the reflector, contact the Customer Service Department at General Dynamics for recommendations involving reflector repair.

### 5.3 **Mount And Reflector Support Structure**

The mount and reflector support structure supplied with this antenna is of steel construction and has a hot-dipped galvanized finish.

If inspection shows any signs of structural failure, the mount members that are damaged should be repaired or replaced.

Corrosion: Any corrosion on steel members may be repaired with a cold, zinc-rich galvanizing paint.

### 5.4 **Feed And Feed Support**

The feed support system should be inspected to insure that all hardware is secure. The feed/radio mounting bolts should be tight.

The feed horn window should be inspected to insure that it is intact so that no moisture can collect inside the feed horn. Replace if damaged.