

GENERAL DYNAMICS
SATCOM Technologies

4096-054
REVISION C
January 4, 2002

ASSEMBLY MANUAL

UNIVERSAL TRIPOD MOUNT
(4.00 O.D.)

GENERAL DYNAMICS SATCOM TECHNOLOGIES
1500 Prodelin Drive
Newton NC 28658

UNIVERSAL TRIPOD MOUNT

INSTALLATION INSTRUCTIONS

C	REPL 0490-072 W/0490-967	11/16/09	RAH
B	Changed Address	01/04/02	RAH
A	Revise area code to 828	10/15/99	RAH
-	ORIGINAL RELEASE	12/14/92	RF
REV.	DESCRIPTION	DATE	APPROVED

TABLE OF CONTENTS

<u>SECTION</u>	<u>TITLE</u>
I	INTRODUCTION
1.0	GENERAL INFORMATION
1.1	SPECIFICATIONS
1.2	UNPACKING & INSPECTION
1.3	FREIGHT DAMAGE
1.4	MATERIAL MISSING OR DAMAGED
1.5	MECHANICAL INSTALLATION TOOLS
II	MOUNT ASSEMBLY
2.0	LOCATION OF TRIPOD ANCHOR BOLTS
2.1	TRIPOD ASSEMBLY
III	MAINTENANCE
3.0	MAINTENANCE OVERVIEW
3.1	PERIODIC INSPECTION
3.2	MOUNT STRUCTURE

SECTION I INTRODUCTION

1.0 GENERAL INFORMATION

This manual describes the assembly and installation of General Dynamics SATCOM Technologies's Universal Tripod Mount. The Universal Tripod Mount is designed to provide a variety of solutions to the problems associated with installing antennas on buildings. The tripod can be mounted on flat or sloping roof surfaces, vertical walls, and concrete ground slabs.

1.1 SPECIFICATIONS

The universal Tripod described in this manual is designed to be used with General Dynamics SATCOM Technologies 's 1.8m Rx Tx and Rx-Only antenna systems. When properly installed, the Universal Tripod can safely support 1.8m antennas in winds up to 125mi/h.

NOTE: Due to the wide variety of building designs and installation configurations possible, it is beyond the scope of this manual to provide details for connection of the tripod to any particular building or other structure. It is the responsibility of the installer to provide suitable foundations or anchorages for this assembly. Maximum forces at the anchor bolts for both vertical and horizontal mounting configurations of the tripod are given in figures 2.0-1 and 2.0-2.

1.2 UNPACKING AND INSPECTION

The system containers should be unpacked and inspected at the earliest date to insure that all material has been received and is in good condition. A complete packing list for each major component is supplied.

1.3 FREIGHT DAMAGE

Any damage to materials while in transit should be immediately directed to the freight carrier. He will instruct you on matters regarding any freight damage claims.

1.4 MATERIAL - MISSING OR DAMAGED

Any questions regarding missing or damaged materials that is not due to the freight carrier should be directed to General Dynamics SATCOM Technologies's Customer Service Department at:

**GENERAL DYNAMICS SATCOM TECHNOLOGIES
1500 Prodelin Drive
Newton NC 28658
(828) 464-4141**

1.5 MECHANICAL INSTALLATION TOOLS

The following tools are suggested for the antenna installation.

TOOL	USED ON
1 drive ratchet - 1/2"	
1 socket, - 15/16"	5/8" anchor bolts
1 socket, - 1 1/2"	1" hardware
1 socket, - 3/4"	1/2" hardware
1 wrench, combination - 15/16"	5/8" anchor bolts
1 wrench, combination - 3/4"	1/2" hardware
1 wrench, combination - 1 1/2"	1" hardware
1 carpenters level or inclinometer	

SECTION 2 MOUNT ASSEMBLY

2.0 LOCATION OF TRIPOD ANCHOR BOLTS

- 2.0.1 For vertical or horizontal installations the dimensions shown in figures 2.0-1 and 2.0-2 may be used to locate the mounting bolts. Note that the tripod holes are sized for 5/8 inch anchor bolts (not included).
- 2.0.2 For flat and sloping roof installations, assemble the tripod according to the instructions in 2.1, keeping all hardware only snug-tight. Position the tripod in the desired location on the slab or sloped roof. Using a level or inclinometer, plumb the mast to vertical by adjusting the legs. When all pads are flush with the mounting surface and the mast is vertical, mark the location for the anchor bolts. This method allows the installer some leeway in choosing the location for the legs (so that they may be positioned over structural members perhaps).

2.1 TRIPOD ASSEMBLY

- 2.1.1 Assemble the legs by placing two of the leg channels (item# 2) back to back and securing with (2) 1/2-13 x 1.50" bolts, (4) flatwashers, (2) lockwashers, (2) 1/2-13 hex nuts (items# 5, 6, 7, 8). Tighten this hardware snug-tight only, so that the legs may be adjusted for length. See figure 2.1-1 and 2.1-2.
- 2.1.2 For flat and sloped roof installations, attach the leg assemblies to the mast weldment (item# 1), as shown in figure 2.1-2. Attach the leg mounting brackets (item# 4) to the legs with the same 1/2" hardware, (all hardware to be snug-tight only). Assemble the base plate (item# 3) to the mast (item# 1) by inserting the 1-8 x 2.00" bolts (item# 9) from inside the mast pipe and through the base plate. Do not use a washer under the head of the bolt, as the hex head will lock into the curve of the pipe and make it easier to tighten this bolt later. Secure with flatwasher, lockwasher, and nut (items# 10, 11, 12). Place the tripod assembly over the anchor bolts or holes and secure to the roof. Check the mast for verticality and then fully tighten all hardware and anchor bolts.
- 2.1.3 For wall mounting, as shown in figure 2.1-1, it may be easier to attach the leg mounting brackets (item# 4) and base plate to the wall first, then attach the leg assemblies to the brackets (item# 3). Attach the mast to the base plate as in 2.1.2 with the 1 inch hardware (items# 9, 10, 11, 12). Swing the mast up and the legs out until the legs can be attached to the mast with the 1/2 inch hardware (items# 5, 6, 7,8). Check the mast for verticality and then fully tighten all hardware and anchor bolts.

1.8M UNIVERSAL TRIPOD MOUNT

HORIZONTAL MOUNTING INTERFACE AND LOADS

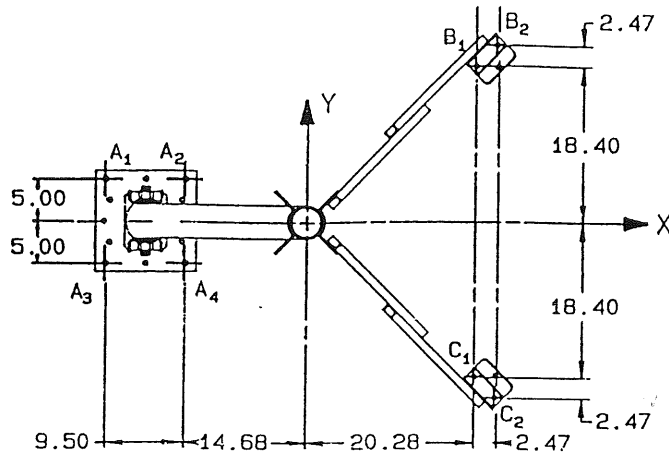

1.8M ANTENNA

	Fx	Fy	Fz
A ₁ ,A ₃	1200	600	930
A ₂ ,A ₄	1200	1700	930
B ₁ ,B ₂	1080	1060	1700
C ₁ ,C ₂	1080	1060	1700

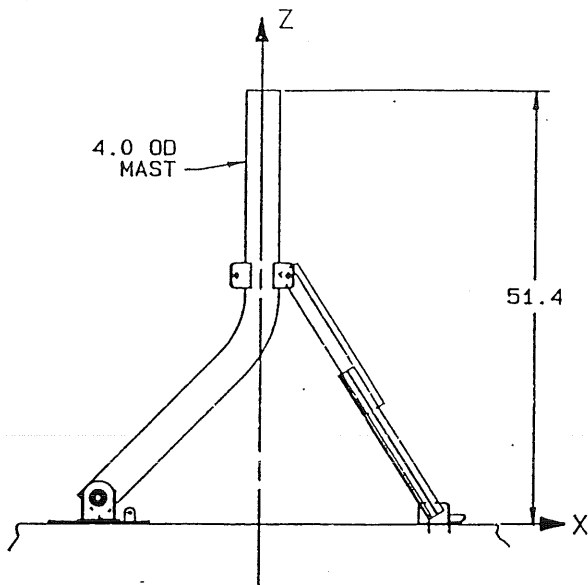

Figure 2.0-1

NOTES:

1. ALL FORCES MAY BE POSITIVE OR NEGATIVE IN DIRECTION.
2. MOUNTING HOLES SIZED FOR 5/8 DIA. ANCHOR BOLTS.

1.8M UNIVERSAL TRIPOD MOUNT

VERTICAL MOUNTING INTERFACE AND LOADS

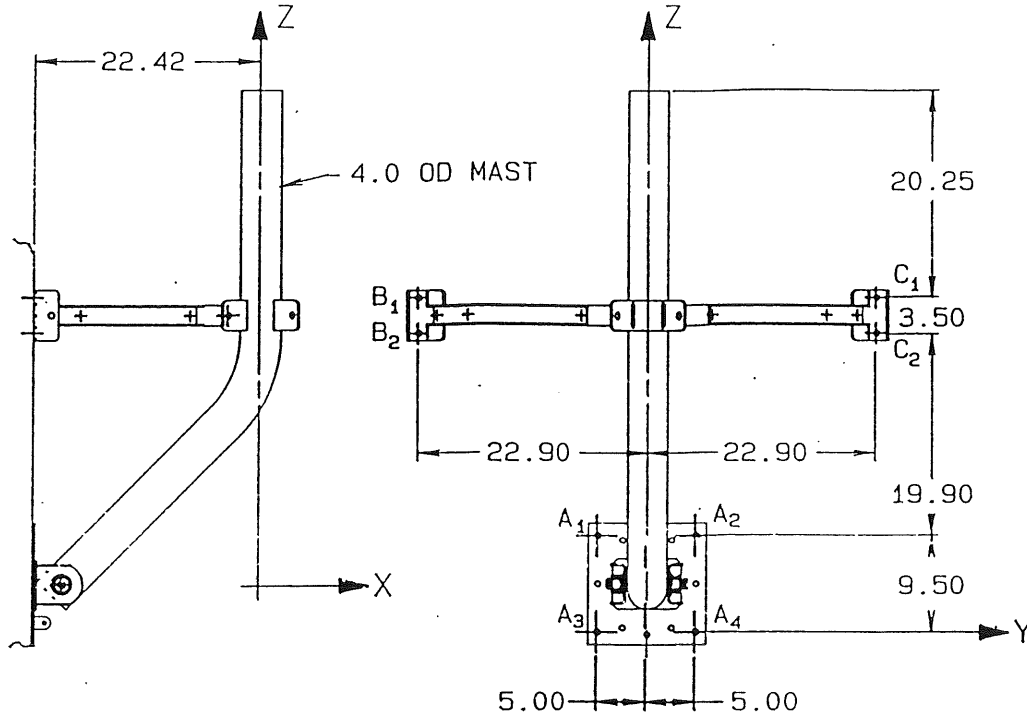

MAXIMUM FORCES IN LBS AT BOLT LOCATIONS FOR 125 Mi/H WIND

1.8M ANTENNA

	Fx	Fy	Fz
A ₁ ,A ₂	2900	820	420
A ₃ ,A ₄	2900	620	420
B ₁ ,B ₂	1530	1570	0
C ₁ ,C ₂	1530	1570	0

FIGURE 2.02

NOTE:

1. ALL FORCES MAY BE POSITIVE OR NEGATIVE IN DIRECTION.
2. MOUNTING HOLES SIZED FOR 5/8 DIA. ANCHOR BOLTS.

UNIVERSAL TRIPOD MOUNT

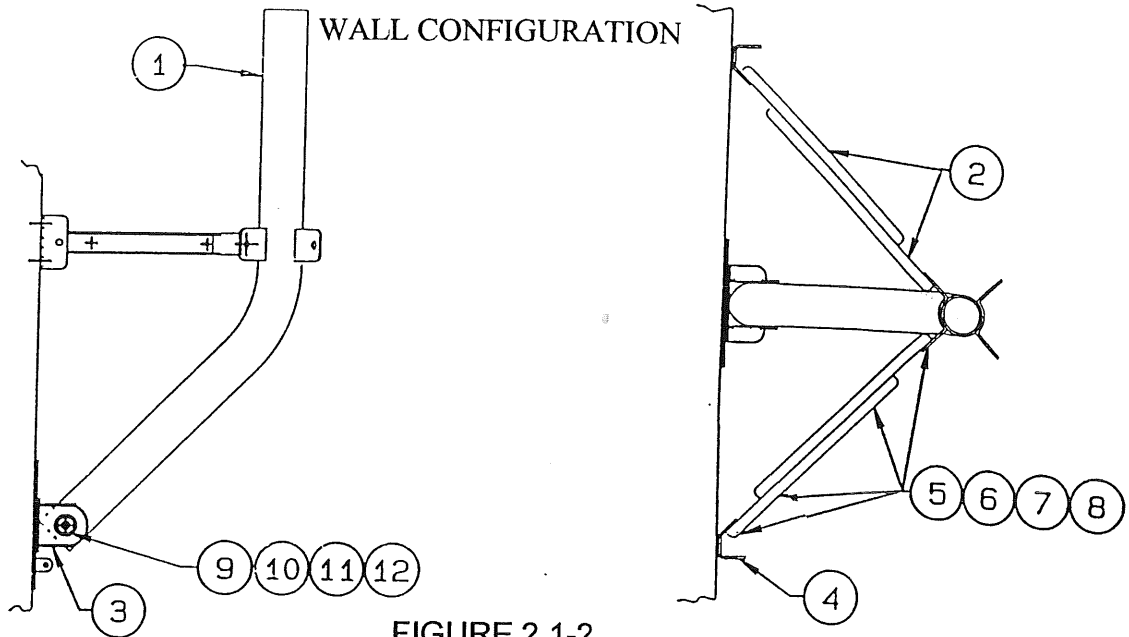

FIGURE 2.1-2

WALL CONFIGURATION			
PARTS LIST			
ITEM#	PART#	DESCRIPTION	QTY
1	0490-967	MAST WELDMENT	1
2	0247-109	LEG CHANNEL	4
3	0490-073	BASE WELDMENT	1
4	0211-345	LEG BRACKET	2
5	8033-012	BOLT, HHCS 1/2-13 x 1.50"	8
6	8201-041	FLATWASHER, 1/2	16
7	8202-043	LOCKWASHER, 1/2	8
8	8104-007	HEX NUT, 1/2-13	8
9	8036-016	BOLT, 1-8 x 2.00"	2
10	8201-046	FLATWASHER, 1"	2
11	8202-046	LOCKWASHER, 1	2
12	8107-007	HEX NUT, 1-8	2

UNIVERSAL TRIPOD MOUNT

GROUND CONFIGURATION

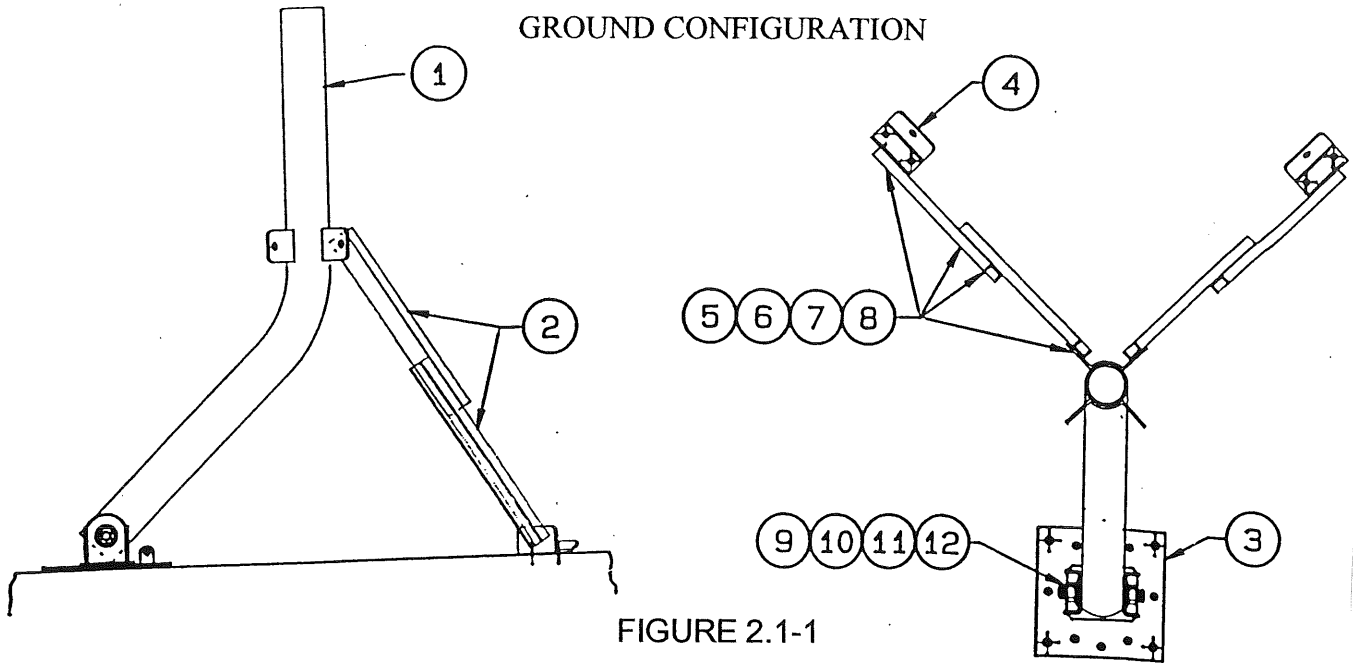

FIGURE 2.1-1

GROUND CONFIGURATION			
PARTS LIST			
ITEM#	PART#	DESCRIPTION	QTY
1	0490-967	MAST WELDMENT	1
2	0247-109	LEG CHANNEL	4
3	0490-073	BASE WELDMENT	1
4	0211-345	LEG BRACKET	2
5	8033-012	BOLT, 1/2 - 13 x 1.50"	8
6	8201-043	FLATWASHER, 1/2	16
7	8202-043	LOCKWASHER, 1/2	8
8	8104-007	HEX NUT, 1/2 - 13	8
9	8036-016	BOLT, 1 - 8 x 2.00"	2
10	8201-046	FLATWASHER, 1	2
11	8202-046	LOCKWASHER, 1	2
12	8107-007	HEX NUT, 1 - 8	2

SECTION III MAINTENANCE

3.0 MAINTENANCE OVERVIEW

After installation, the mount requires only periodic inspection. It is anticipated that maintenance, if required, will be minimal and easily handled by a local or in-house maintenance staff. The materials used in the construction of this Universal Tripod Mount virtually eliminate any maintenance repairs.

3.1 PERIODIC INSPECTION

It is suggested that a periodic inspection be performed at least every six months.

NOTE: After any severe weather conditions, inspection of the antenna should be performed to determine if foreign objects have caused damage or if survival specifications have been exceeded.

This inspection should include the following:

STEP 1: Check all bolting locations - all bolts should be tight.

STEP 2: Check all structural members - repair or replace if damaged.

STEP 3: Check the foundation anchor bolts - they must be secure and no failure signs in foundation.

STEP 4: Check for corrosion - on the reflector structure and the mount.

4.3 MOUNT STRUCTURE

The mount and reflector support structure supplied with this antenna is of steel construction and has a hot-dip galvanized finish.

If inspection shows any signs of structural failure, the mount members that are damaged should be repaired or replaced.

CORROSION: Any corrosion on steel members may be repaired with a cold, zinc-rich galvanizing paint.