



4096-523

**January 21, 2002
Revision B**

Assembly Manual

**2.4 METER SERIES 1254
DUAL OPTICS ANTENNA SYSTEM
C-BAND**

**PRODELIN CORPORATION
1500 Prodelin Drive
Newton NC 28658**

2.4 Meter 2 Piece Az/EI Installation Instructions

B	Revised text	7/14/04	
A	Revised Address	1/2/02	CLT
-	Original Release	8/27/98	CLT
REV.	DESCRIPTION	DATE	APPROVED

2.4M SERIES 1254 ANTENNA SYSTEM WITH DUAL OPTICS**TABLE OF CONTENTS**

<u>SECTION</u>	<u>TITLE</u>
I	GENERAL INFORMATION
1.0	INTRODUCTION
1.1	UNPACKING AND INSPECTION
1.2	FREIGHT DAMAGE
1.3	MISSING OR DAMAGED MATERIAL
1.4	SUGGESTED TOOL LIST
1.5	MECHANICAL ALIGNMENT TOOLS
1.6	SUGGESTED MAST & FOUNDATION
II	ANTENNA SYSTEM
2.0	ASSEMBLY OVERVIEW
2.1	CANISTER & AZ/EL POSITIONER INSTL
2.2	REFLECTOR SUPPORT ASSEMBLY & REFLECTOR INSTALLATION
III	FEED SUPPORT
3.0	FEED SUPPORT INSTALLATION
IV	ANTENNA POINTING
4.0	ALIGNMENT TO SATELLITE
4.1	INITIAL ALIGNMENT
V	MAINTENANCE
5.0	MAINTENANCE OVERVIEW
5.1	PERIODIC INSPECTION
5.2	REFLECTOR
5.3	MOUNT AND REFLECTOR SUPPORT
5.4	FEED AND FEED SUPPORT

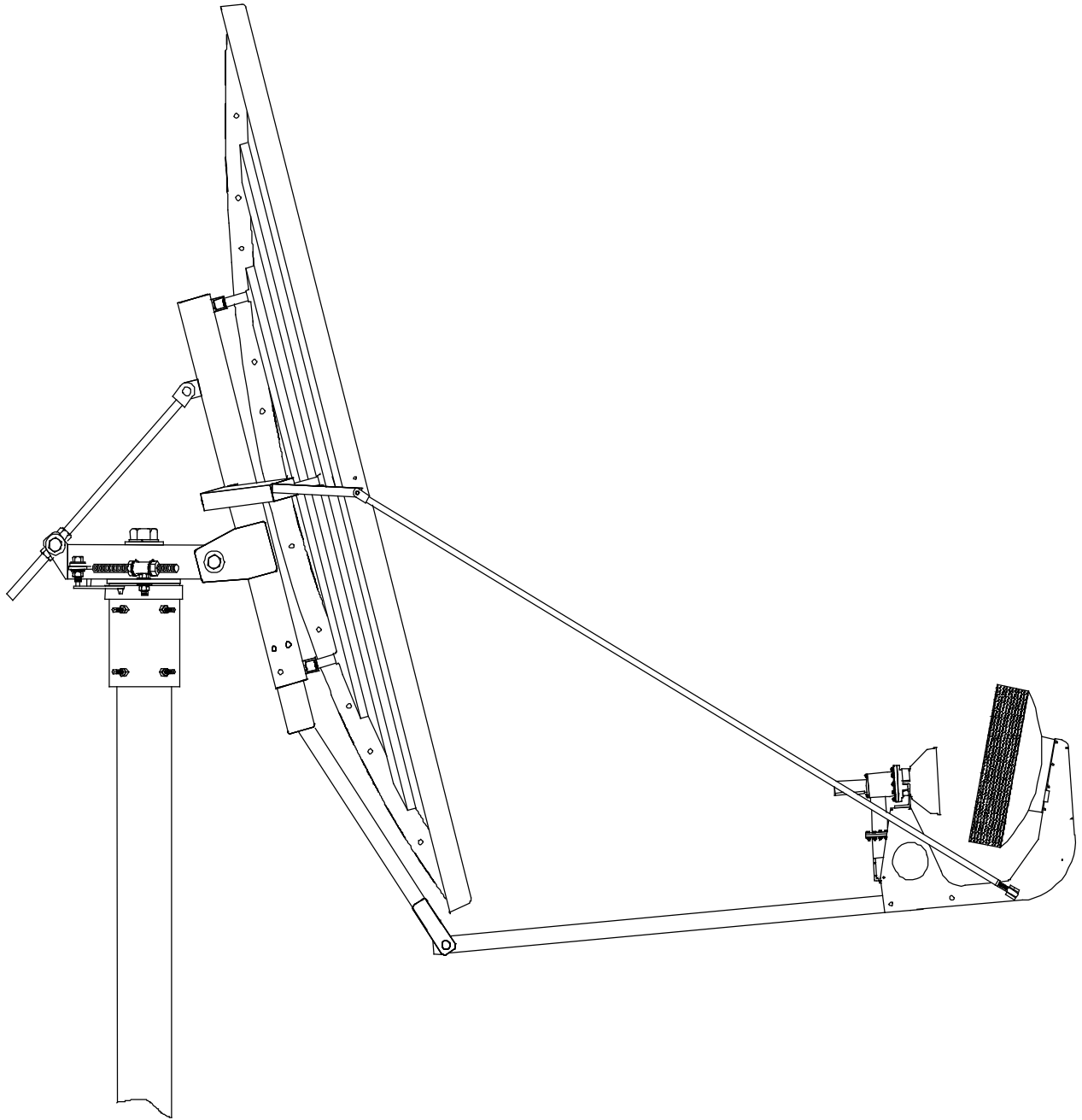

SECTION I GENERAL INFORMATION**1.0 Introduction**

This manual describes the assembly and installation of Prodelin's 2.4M 2-Piece Rx/Tx offset antenna system with an Az/EI mount and Dual Optics (series number1254). The Prodelin 2.4M is a rugged, reliable antenna system that will operate at C-band frequencies with high efficiency and at the same time successfully withstand the effects of the environment.

These instructions are listed by sections that cover all areas of assembly and installation. Additional sections are included in the manual to provide information on antenna alignment to the satellite and maintenance.

1.1 Unpacking And Inspection

The antenna containers should be unpacked and inspected at the earliest date to ensure that all material has been received and is in good condition. A complete packing list for each major component is supplied.

1.2 Freight Damage

Any damage to materials while in transit should be immediately directed to the freight carrier. He will instruct you on matters regarding any freight damage claims.

1.3 Material - Missing Or Damaged

Any questions regarding missing or damaged materials that is not due to the freight carrier should be directed to Prodelin's Customer Service Department at:

PRODELIN CORPORATION
1500 Prodelin Drive
Newton NC 28658
(828) 464-4141

1.4 Suggested Tool List

The following tools are suggested for the antenna installation.

1 ratchet

1 socket - 9/16"

1 socket - 3/4"

1 socket - 1-1/8"

1 wrench, combination - 7/16"

1 wrench, combination - 1/2"

1 wrench, combination - 9/16"

1 wrench, combination - 3/4"

1 wrench, combination - 15/16"

1 wrench, combination - 1-1/8"

1 wrench, combination - 1-1/2"

1 wrench, adjustable - 10"

1 3" wrench (socket, crescent, or pipe) for 2" bolt

1.5 Mechanical Alignment Tools

The following tools are suggested for the initial alignment to the satellite.

- 1) COMPASS
- 2) INCLINOMETER
- 3) TAPE RULER - 10 ft. MINIMUM

1.6 SUGGESTED MAST & FOUNDATION

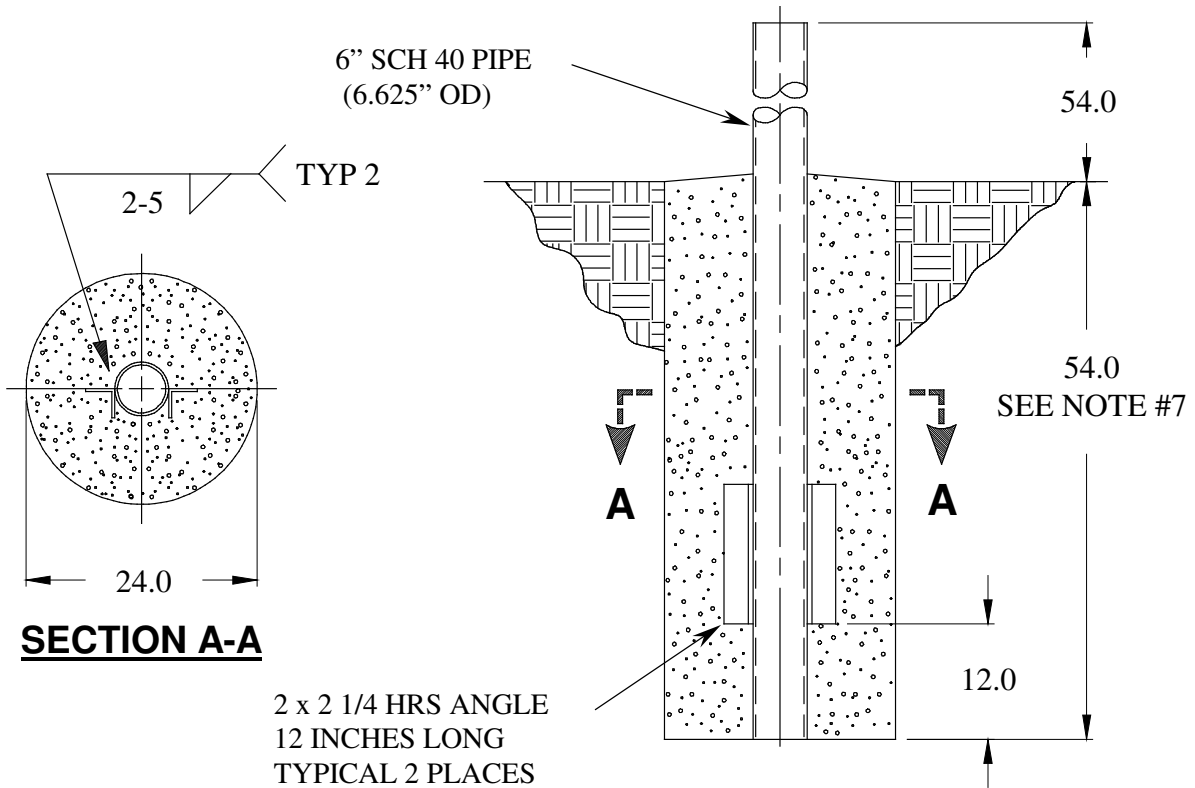

NOTES:

1. 2 x 2 x 1/4 HRS Angle and schedule 40 pipe should conform with ASTM A36 and ASTM A53 Type E and S Grade B.
2. All concrete should conform to building code standards and have a minimum compressive strength of 3000 PSI at 28 days. (Per ACI-318-77)
3. Soil bearing capacity should be no less than 2000 PSF.
4. Concrete should be poured against undisturbed soil.
5. Allow concrete 24 hours set time before installation of antenna.
6. The antenna should be properly grounded to meet applicable local codes.
7. Minimum depth as shown or extend to local frost line.
8. Foundation meets the design requirements as set forth by the uniform building code. (1982 edition)

(PRODELIN CORPORATION DOES NOT REPRESENT OR WARRANT THAT ANY PARTICULAR DESIGN OR SIZE OF FOUNDATION IS APPROPRIATE FOR ANY LOCALITY OR EARTH STATION INSTALLATION.)

SECTION II ANTENNA ASSEMBLY

CAUTION: During the assembly procedure, the sequence of instructions must be followed. DO NOT TIGHTEN ANY HARDWARE UNTIL INSTRUCTED.

2.0 Assembly Overview

The 2.4 meter dual optics antenna system consists of four (4) major components:

- 1) Reflector (2 petals)
- 2) Reflector Support Assembly
- 3) Az/El Positioner Assembly
- 4) Feed Support and Sub-reflector Assemblies

The interface from the ground foundation to the antenna is a vertical 6.63" OD pipe. It is assumed that the foundation and pipe have been properly installed.

2.1 Canister and Az/El Positioner Installation

As shown in figure 2.1-1, place the canister assembly [item #1] on the mast pipe, observing the following points:

- Step 1: Back out the [8] 5/8" set screws so that the canister can slip over the pipe. Snug the [8] 5/8" set screws..
- Step 2: Loosen the 2" bolt and rotate the positioner (rectangular tube) to be at right angles to the canister plate as shown. Remove the azimuth rod from the positioner. Run one of the 1" nuts up towards the tab end of the rod; and remove the other 1" nut and one washer. Place the rod through the adjustment tube attached to the canister top plate, and replace the washer and nut. Re-attach the azimuth rod to the Az/El positioner with the 3/4-10 x 2.00" bolt, two flat washers, lock washer, nut and .80" sleeve. Tighten securely. Snug the 2" bolt at this time.
- Step 3: The canister must be oriented correctly to the center of the satellite orbital arc. Loosen the set screws and rotate the canister on the pipe to the required position. Refer to figure 2.1-1. Tighten the set screws securely, and tighten the 5/8" lock nuts against the canister.

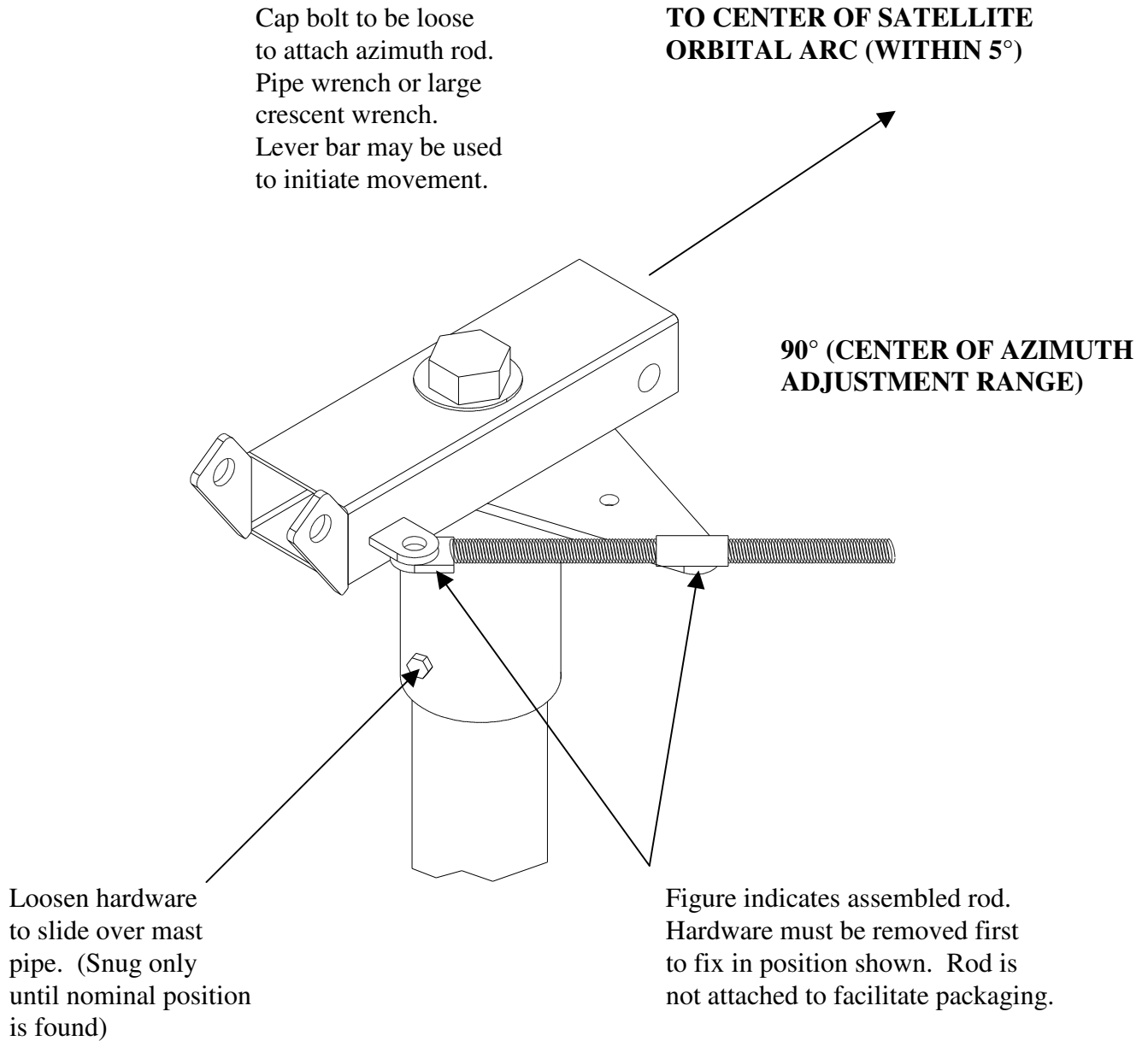

POSITIONER INSTALLATION

FIGURE 2.1-1

TABLE 2.1-1

PARTS LIST

ITEM #	PART #	DESCRIPTION	QTY
1	0181-691	2.4M 2Pc Az/El Positioner Assy	1

2.2 Reflector Support Assembly & Reflector Installation

The reflector support assembly consists of a 2 Piece reflector support tube and three reflector crossarms which provide the necessary structural support and alignment positions on which the reflector petals are mounted.

The reflector petals are labeled “A” and “B” with “A” being the left side when viewed from behind and “B” being the right side. In the standard upright position (feed support at bottom), the antenna’s elevation range is 5° to 90°.

Step 1: Place three of the threaded inserts (item 3) through the face of each reflector petal (item 1 & 2) and secure with 3/4” flat washer, lock washer, and hex nut. (items 8,9, & 10). Snug, but do not completely tighten at this time. See figure 2.2-1.

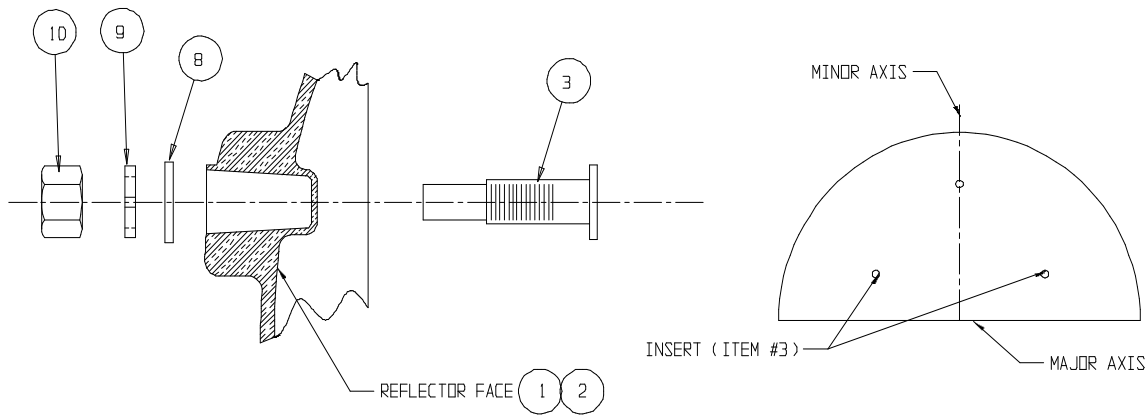

Figure 2.2-1

Step 2: Remove the 1” diameter bolt from the elevation axis of the Az/EI positioner and place the reflector support tube (item #4) on the positioner as shown in figure 2.2-2 . Replace the 1” bolt and tighten snug only. Let the tube lie down on the positioner.

Step 3: Attach the top & bottom crossarms (items 5) to the reflector support tube with a 1/2 - 13 x 2.50" bolt, [2] flat washers, lock washers, and hex nut (items 11,12,13, & 14) in each of four locations as shown in figure 2.2-2. Do not tighten.

Step 4: Place one reflector petal onto the crossarms in the upright position (see figure 2.2-3) and attach with a 3/8 - 16 x 1.25" bolt, flat washer, and lock washer (items 18, 19, & 20) at each crossarm. **Do not tighten.**

Step 5: Place the second reflector petal onto the crossarms and attach as in step #4.

Step 6: Insert steel template between reflector petals then attach the two petals together with 1/2-13 x 1.25" bolts, two narrow flat washers, lock washer, and hex nut (item 16, 17, 13, & 14) in the 9 locations as shown in figure 2.2-4. Tighten these bolts securely at this time while aligning the petals at the face of reflector.

Step 7: Carefully swing the reflector up into a vertical position. Remove the bottom 1" hex nut and flat washer from the elevation adjustment assembly (item 6) and insert the assembly through the elevation adjustment tube at the back of the Az/EI positioner as shown in figure 2.2-5. Replace the flat washer and hex nut.

Step 8: Remove the 3/4" hardware and sleeve from the end of the elevation assembly and attach to the reflector support tube. Tighten securely.

Step 9: Attach the center crossarm (item 7) to the reflector support tube with a 1/2-13 x 5.00" bolt, two flat washers, lock washer, and hex nut (item 15,12,13, & 14) in each of the two locations as shown in figure 2.2-6.

Step 10: Attach the center crossarm to the reflector petals at the two(2) threaded inserts (item 3) with 3/8 - 16 x 4.00" bolt, flat washer, and lock washer (item 18, 19, & 20).

Step 11: Tighten the reflector support hardware by first tightening the 3/4" hardware at the six reflector inserts followed by the 3/8" bolts holding the reflector to the three crossarms. Next tighten the [6] 1/2" bolts holding the three crossarms to the reflector support tube. Do not tighten the elevation hardware until after satellite alignment.

2.4 METER AZ/EL PARTS LIST			
ITEM	PART NO.	DESCRIPTION	QTY
1	0179-381 0179-383	Reflector "A" Side Reflector "A" Side w/SHC	1
2	0179-382 0179-384	Reflector "B" Side Reflector "B" Side w/SHC	1
3	0159-283	Threaded insert	4
4	0490-676	Reflector Support Tube	1
5	0250-696	Top and Bottom Crossarm	2
6	0181-249	Elevation Adjustment assembly	1
7	0490-633	Center Crossarm	1
8	8201-045	3/4" Flat washer	6
9	8200-015	3/4" Lock washer	6
10	8106-007	3/4 Nut	6
11	8033-021	1/2-13 x 2.50" bolt	4
12	8201-043	1/2" Flat washer - wide	12
13	8202-043	1/2" Lock washer	15
14	8104-007	1/2" Nut	15
15	8033-040	1/2-13 x 5.00 bolt	2
16	8033-010	1/2"-13 x 1.25 bolt	9
17	8201-030	1/2" Flat washer - narrow	18
18	8032-010	3/8"-16 x 1.25" bolt	4
19	8201-042	3/8" Flat washer	6
20	8202-042	3/8" Lock washer	6
21	8032-032	3/8"-16 x 4.00" bolt	2

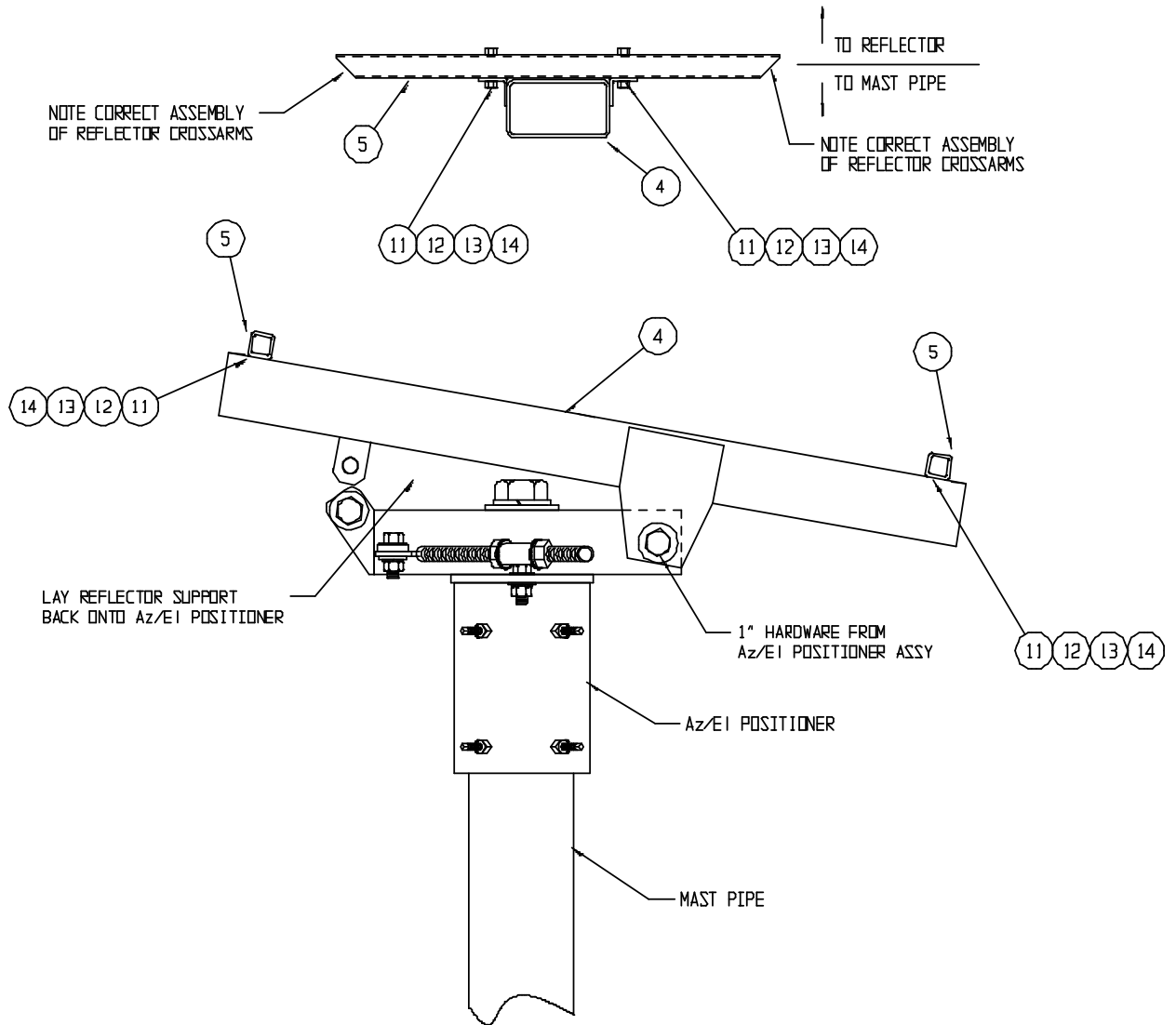
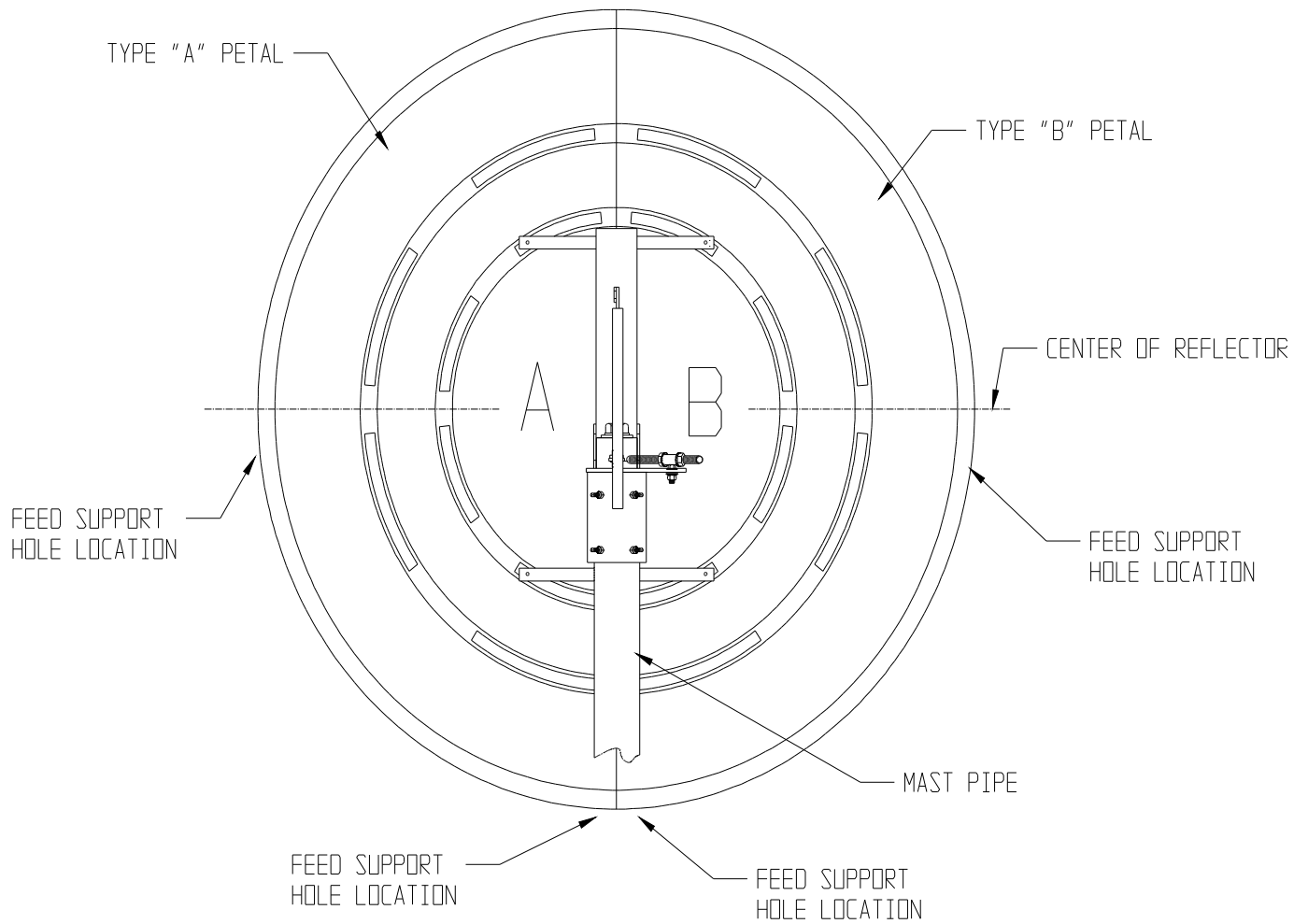

Figure 2.2-2



REFLECTOR IN UPRIGHT (NORMAL) POSITION

Figure 2.2-3

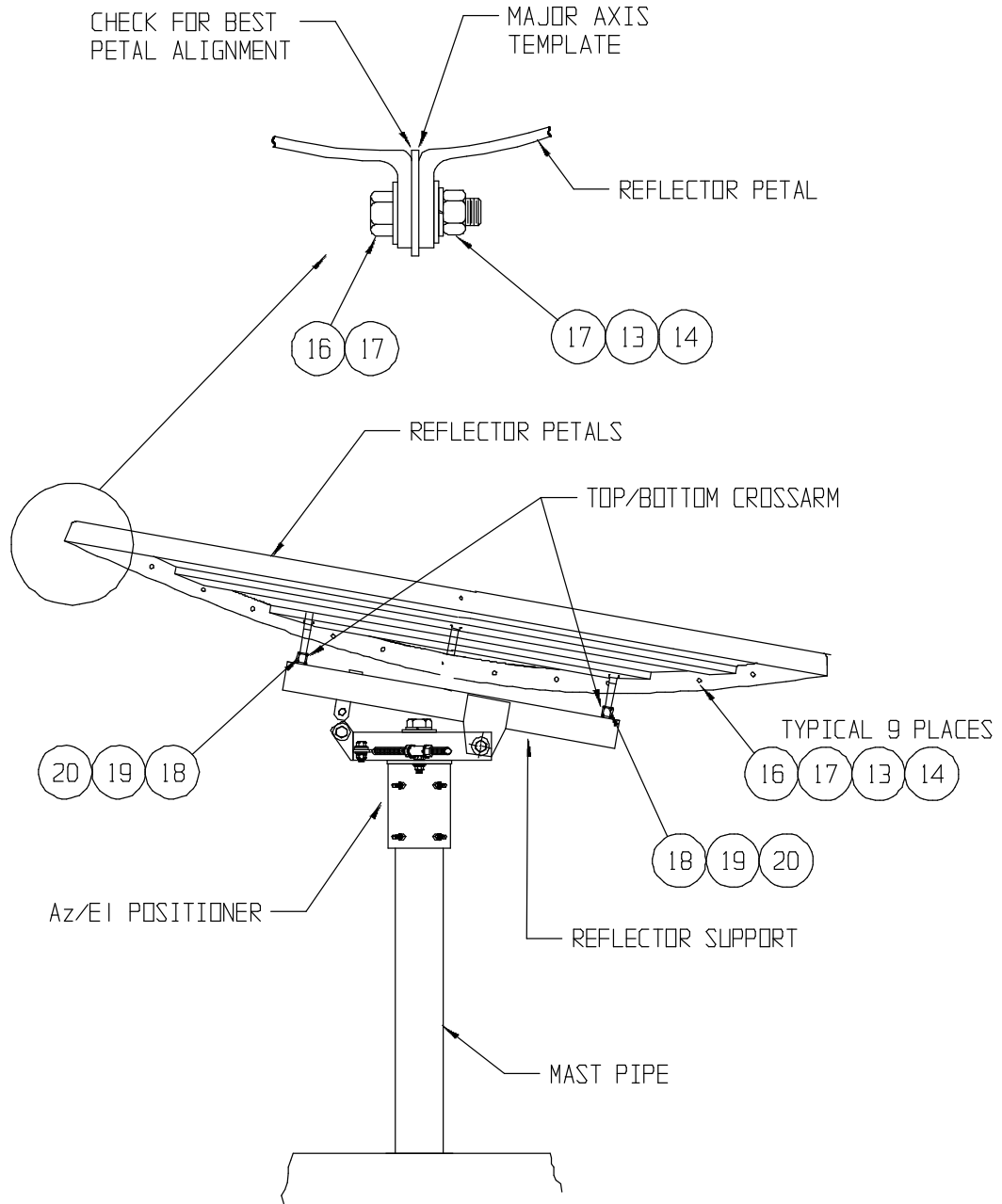

Figure 2.2-4

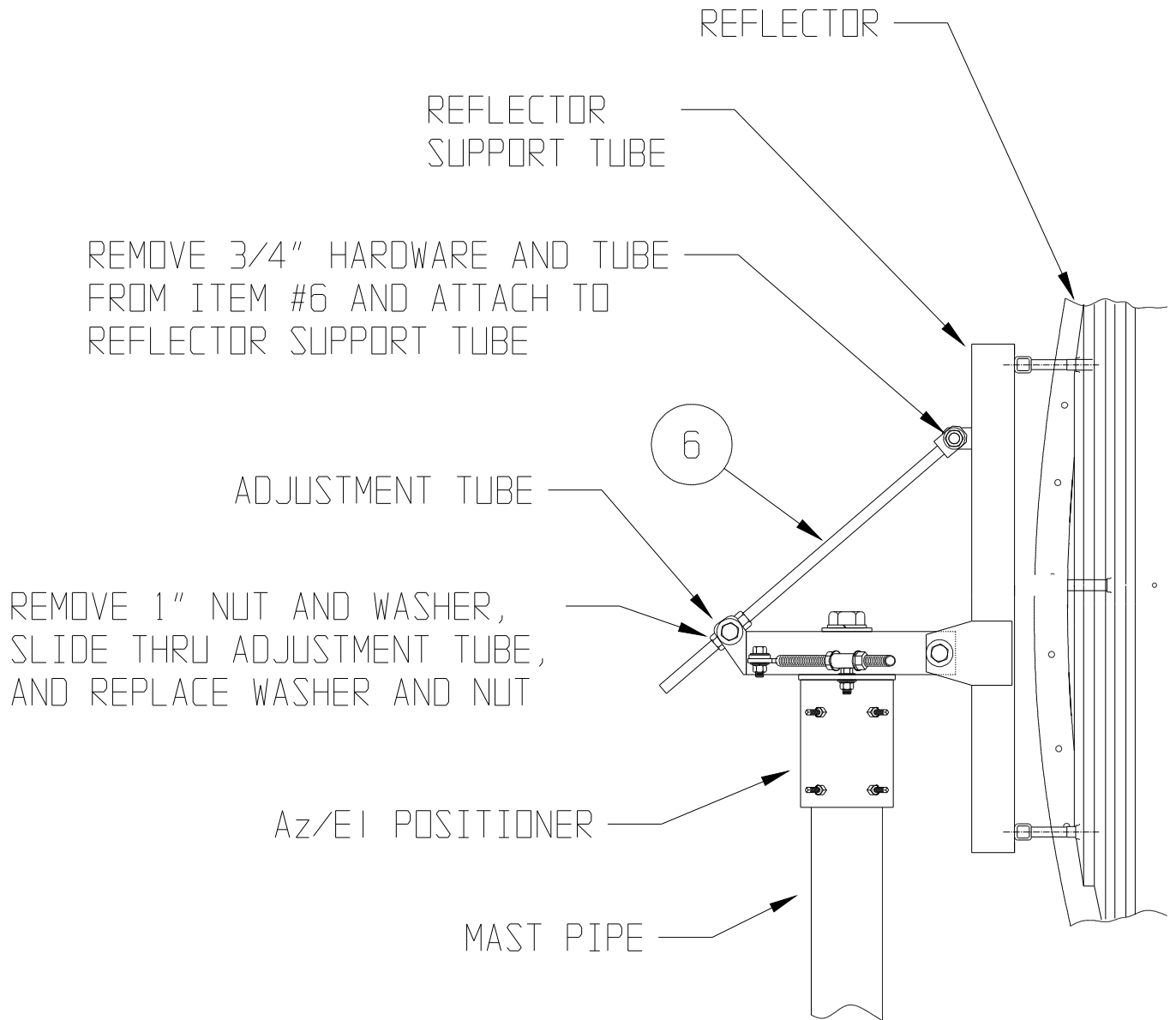

Figure 2.2-5

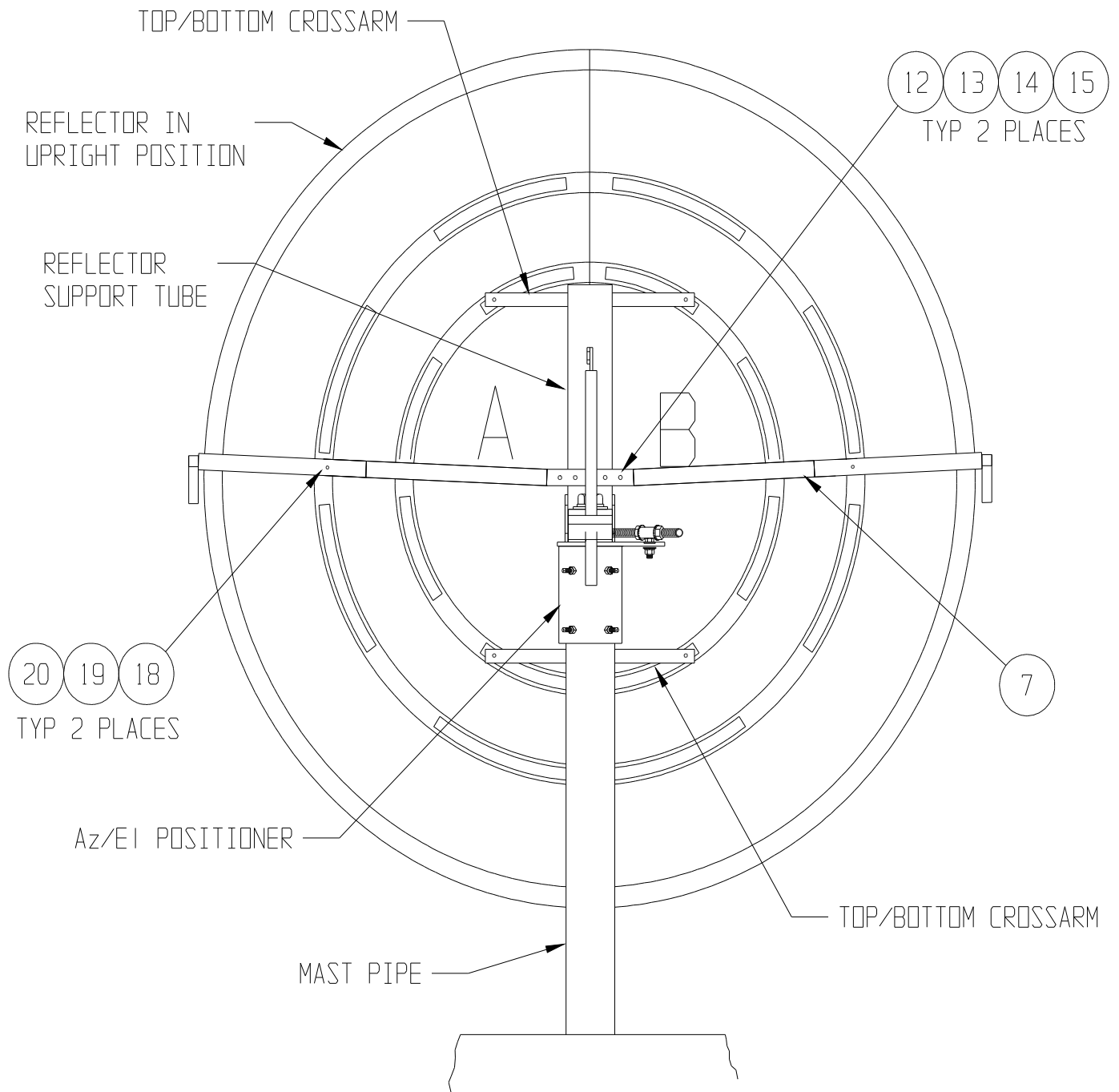

Figure 2.2-6

SECTION III FEED SUPPORT ASSEMBLY

The following instructions are for installing a C-band dual optics feed support to Prodelin's 2.4 meter antenna system.

3.0 Feed Support Installation

1. Attach feed support extension (item #16) to reflector support tube using (6)1/2-13 x 1.50 bolts, flat washers, lock washers. Center extension with reflector major axis while tightening. Reference Figure 3.0-0
2. Attach the longer flat end of the feed rods loosely to the outside of the crossarm with 5/16-18 x 1.50" bolts, flat washers, lock washers and nuts. Reference Figure 3.0-1.
3. Lift the end of the feed support tube and attach to the bottom of the feed extension with a 1"-8 x 6.00" bolt, flatwashers, lockwasher, and hex nut. Reference Figure 3.0-2.
4. Position Sub-reflector cradle assembly at end of feed support tube (sub-reflector facing main reflector) and secure using (2) 3/8-16 x 5.00" bolts, flat washers, lock washers and nuts.
5. Secure the unattached ends of the feed rods on to the sides of the feed support tube using a 3/8-16 x 5.00" bolt, flat washers, lock washer, and hex nut as shown in Figure 3.0-3.

FEED SUPPORT PARTS LIST			
ITEM	PART NO.	DESCRIPTION	QTY
1	0250-695	Feed Support	1
2	0176-279	Feed Rod	2
3	8031-012	5/16-18 x 1.50" bolt	2
4	8032-040	3/8-16 x 5.00" bolt	3
5	8036-048	1-8 x 6.00" bolt	1
6	8201-041	5/16" Flat Washer	4
7	8201-042	3/8" Flat Washer	6
8	8201-046	1" Flat Washer	2
9	8202-041	5/16" Lock Washer	2
10	8202-042	3/8" Lock Washer	3
11	8202-046	1" Lock Washer	1
12	8101-009	5/16-18 Hex Nut	2
13	8102-007	3/8-16 Hex Nut	3
14	8107-007	1-8 Hex Nut	1
15	0490-632	Weldment, Feed Extension	1

C-BAND DUAL OPTICS FEED ROD MOUNTING

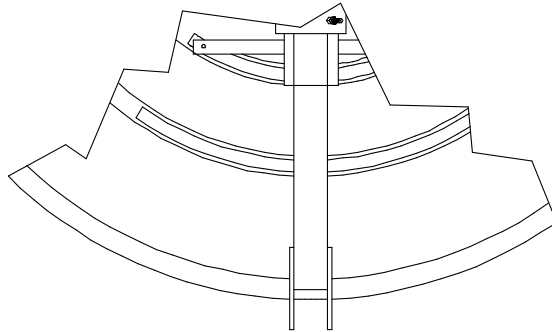

Figure 3.0-0

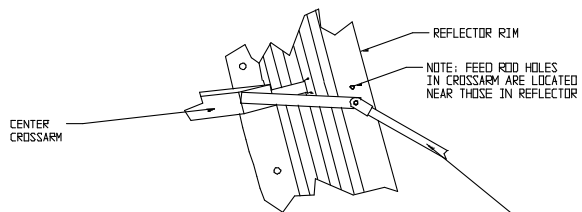

Figure 3.0-1

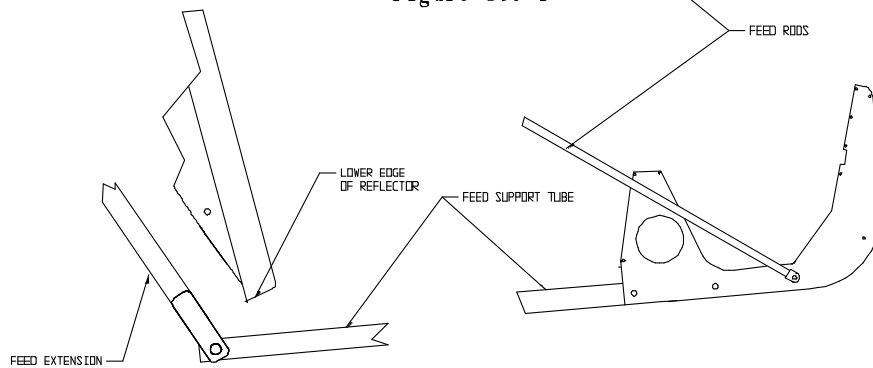

Figure 3.0-2

Figure 3.0-3

SECTION IV ANTENNA POINTING**4.0 Alignment To Satellite**

The 2.4M offset reflector contains a 22.3° elevation offset angle. Therefore, when the reflector aperture is perpendicular to the ground, the antenna is actually looking 22.3° in elevation. The following alignment procedure is intended only as a general reference guide for this antenna. For proper antenna performance, accurate alignment is critical. Therefore, it is recommended that your own detailed procedure be used or contact Prodelin's Technical Support Department for additional recommendations.

4.1 Initial Alignment

- 1) Place an inclinometer on the reflector support as shown in figure 4.1-1. Remember to add 22.3° to the reading to allow for the reflector's offset angle.
- 2) Raise or lower the antenna to find the desired elevation by turning the 1" nuts located at the elevation block. Position the top nut so that it will not interfere with adjustment. Turn the bottom nut clockwise to increase elevation and counterclockwise to decrease elevation.
- 3) After the correct elevation angle is set, rotate the antenna in azimuth by loosening the 1" nuts on the azimuth adjustment rod. Rotate azimuth until a signal is reached.
- 4) Peak the antenna signal by fine adjustments made in both azimuth and elevation.
- 5) Tighten all of the hardware used for adjustments.
- 6) Tighten 2" bolt.

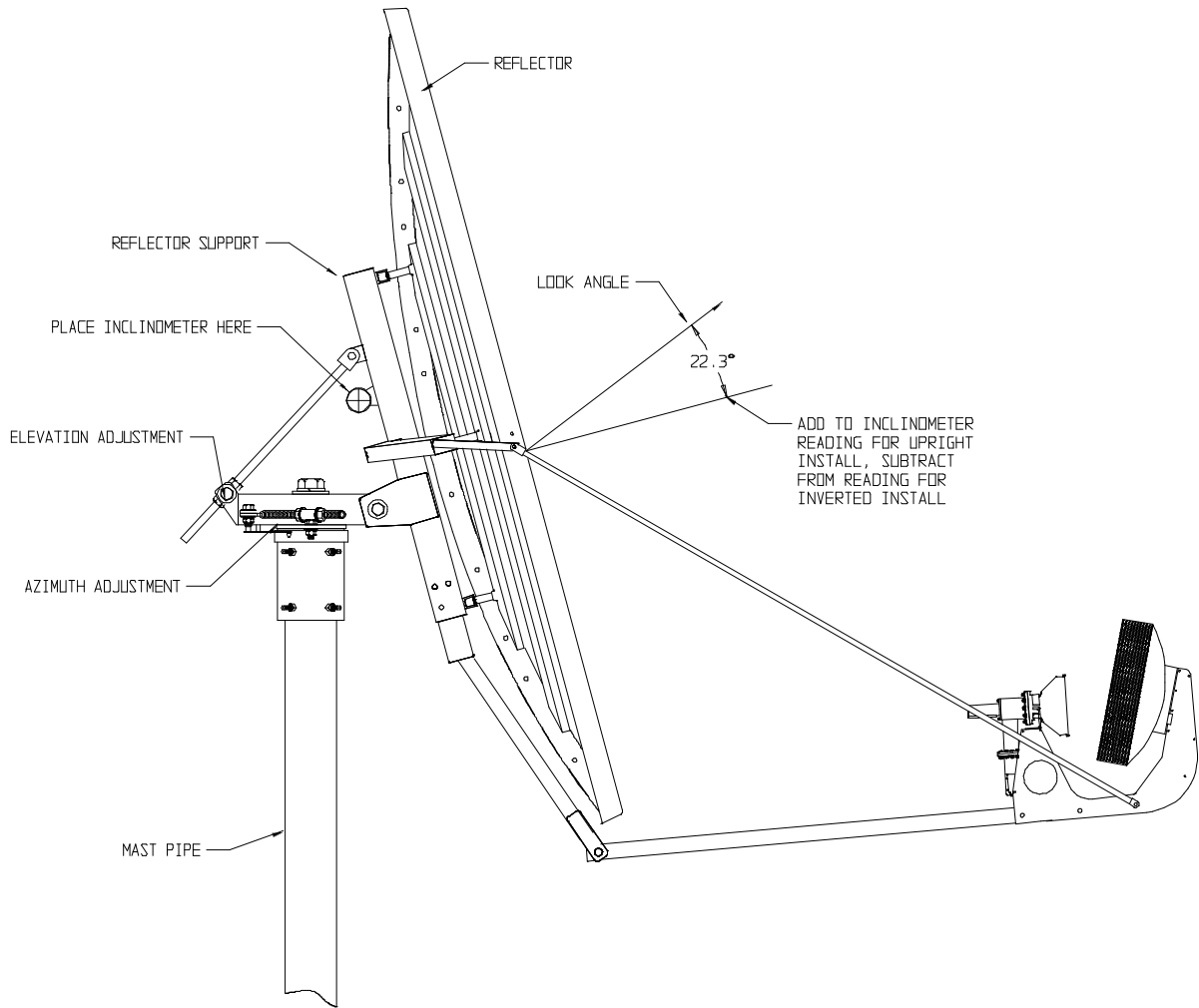

Figure 4.1-1

SECTION V MAINTENANCE**5.0 Maintenance Overview**

After installation, the antenna requires only periodic inspection. It is anticipated that maintenance, if required, will be minimal and easily handled by a local or in-house maintenance staff. The materials used in the construction of this Earth Station Antenna virtually eliminate any maintenance repairs.

5.1 Periodic Inspection

It is suggested that a periodic inspection be performed at least every six months.

NOTE: After any very severe weather conditions, inspection of the antenna should be performed to determine if foreign objects have caused damage or if survival specifications have been exceeded.

This inspection should include the following:

- 1) Check all bolting locations - all bolts should be tight.
- 2) Check all structural members - repair or replace if damaged.
- 3) Check the foundation anchor bolts - they must be secure and with no failure signs in foundation.
- 4) Check for corrosion - on the reflector structure and mount.

5.2 Reflector

Prodelin's reflector does not require any maintenance. The composite construction of the reflector is virtually impervious to any damages that could be caused by weather or other atmospheric conditions.

It is only necessary to inspect for any physical damage done by vandalism or very severe weather conditions.

Should any damage be detected to a portion of the reflector, contact the Customer Service Department at Prodelin for recommendations involving reflector repair.

5.3 **Mount And Reflector Support Structure**

The mount and reflector support structure supplied with this antenna is of steel construction and has a hot-dipped galvanized finish.

If inspection shows any signs of structural failure, the mount members that are damaged should be repaired or replaced.

Corrosion: Any corrosion on steel members may be repaired with a cold, zinc-rich galvanizing paint.

5.4 **Feed And Feed Support**

The feed support system should be inspected to insure that all hardware is secure. The feed/radio mounting bolts should be tight.

The feed horn window should be inspected to insure that it is intact so that no moisture can collect inside the feed horn. Replace if damaged.