



4096-536  
Revision E  
July 13, 2000

**ASSEMBLY MANUAL**

# **4-PC 2.4M ANTENNA SYSTEM W/DUAL AXIS TRACKING MOUNT**

**PRODELIN CORPORATION  
1500 Prodelin Drive  
Newton NC 28658**

# 4-PC 2.4M Antenna System W/ Dual Axis Tracking Mount

E	Remove Seatel Controller Instructions	3/31/05	
D	Revised Address	2/11/02	RAH
C	Rev. Frame to 0181-990	7/13/00	RAH
B	Text revision page 20	06/29/99	RF
A	Overall Update	04/01/98	PGW
-	ORIGINAL RELEASE	4/14/97	PGW
<b>REV.</b>	<b>DESCRIPTION</b>	<b>DATE</b>	<b>APPROVED</b>

---

**TABLE OF CONTENTS**

<b><u>SECTION</u></b>	<b><u>TITLE</u></b>
<b>I</b>	<b>GENERAL INFORMATION</b>
1.0	INTRODUCTION
1.1	UNPACKING AND INSPECTION
1.2	MECHANICAL INSTALLATION TOOLS
1.3	SITE SELECTION
1.4	SUGGESTED MAST & FOUNDATION
<b>II</b>	<b>REFLECTOR AND SUPPORT ASSEMBLY</b>
2.0	PART LIST
2.1	DUAL AXIS TRACKING MOUNT INSTALLATION
2.2	REFLECTOR QUADRANT ORIENTATION
2.3	REFLECTOR SUPPORT ASSEMBLY
<b>III</b>	<b>FEED SUPPORT AND STABILIZATION KIT</b>
3.0	PART LIST
3.1	FEED SUPPORT ASSEMBLY
<b>IV</b>	<b>ANTENNA TRACKING CONTROLLER SET UP</b>
4.0	ANTENNA CONTROLLER UNIT SET UP
<b>VI</b>	<b>MAINTENANCE</b>
5.0	MAINTENANCE OVERVIEW
5.1	PERIODIC INSPECTION
5.2	REFLECTOR
5.3	MOUNT AND REFLECTOR SUPPORT
5.4	FEED AND FEED SUPPORT
5.5	BEARINGS
5.6	ACTUATOR

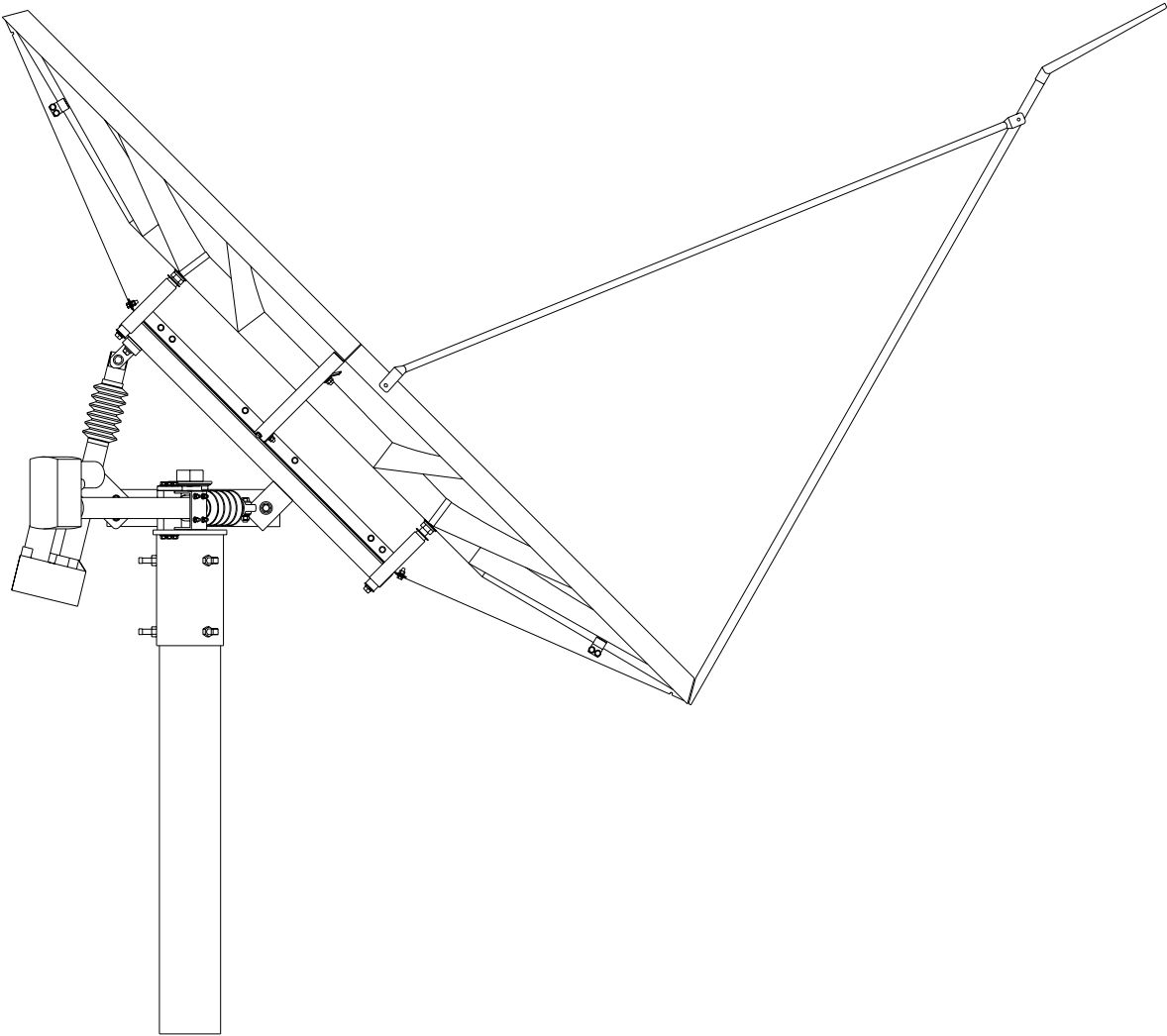

## 1.0 **INTRODUCTION**

This manual describes the assembly and installation of Prodelin's 2.4M 4-Piece antenna system with Dual Axis Tracking. The Prodelin 2.4M is a rugged, reliable antenna system that will operate in the Ku-band frequency with high efficiency and at the same time successfully withstand the effects of the environment. These instructions are listed by sections that cover all areas of assembly and installation. Additional sections are included in the manual to provide information on antenna alignment to the satellite and maintenance.

## 1.1 **UNPACKING AND INSPECTION**

1. **UNPACKING & INSPECTION** - The antenna containers should be unpacked and inspected at the earliest date to ensure that all material has been received and is in good condition. A complete packing list for each major component is supplied.
  
2. **FREIGHT DAMAGE** - Any damage to materials while in transit should be immediately directed to the freight carrier. He will instruct you on the matters regarding any freight damage claims.
  
3. **MATERIAL - MISSING OR DAMAGED** - Any questions regarding missing or damaged materials that is not due to freight carrier should be directed to Prodelin's Customer Service Department at:

**PRODELIN CORPORATION  
1500 Prodelin Drive  
Newton NC 28658  
USA  
(828) 464-4141**

## 1.2 **MECHANICAL INSTALLATION TOOLS**

HARDWARE SIZE	SAE WRENCH SIZE	METRIC WRENCH SIZE	MAXIMUM REC. TORQUE
5/16"	1 / 2"	13 mm	12 ft-lbs
3 / 8"	9 / 16"	14 mm	15 ft-lbs
1 / 2"	3 / 4"	20 mm	35 ft-lbs
5 / 8"	15 / 16"	24 mm	70 ft-lbs
7 / 8"	1 – 1 / 4"	32 mm	190 ft-lbs

- 1 Screwdriver, standard blade
- 1 Screwdriver, cross blade
- 1 10" adjustable crescent wrench
- 1 Allen wrench, 5/32"
- 1 3" (76mm) wrench (socket, crescent or pipe) for 2"-4.5 bolt
- 1 Cordless Drill, 3/8" ( recommended)
- 1 Compass
- 1 Inclinator
- 1 ASCII Hand Held Terminal (a personal computer with ASCII Emulator software can be used)

### 1.3 SITE SELECTION

In order to achieve maximum performance of your antenna system, it is important to select the correct location for the antenna. The following guidelines should be observed when selecting a site for the installation.

1. The line of site to the satellite should be clear of any obstructions, such as trees or buildings.
2. The site should be relatively flat and level for ease of installation and access to the antenna.
3. The site should be checked for underground obstruction, such as buried cables or pipes.
4. All local building codes should be adhered to (i.e. grounding, foundation requirements, zoning rules, setbacks, etc.).

### 1.4 SUGGESTED MAST & FOUNDATION

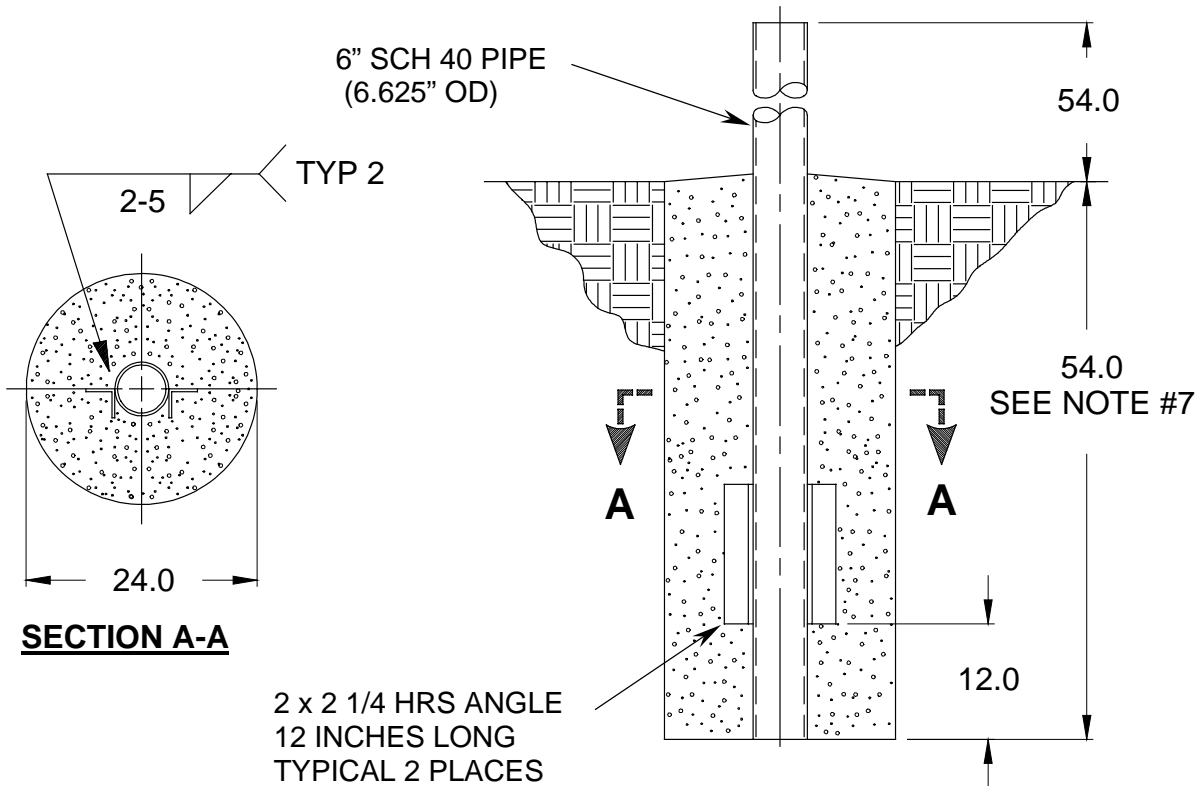

**NOTES:**

1. 2 x 2 x 1/4 HRS Angle and schedule 40 pipe should conform with ASTM A36 and ASTM A53 Type E and S Grade B.
2. All concrete should conform to building code standards and have a minimum compressive strength of 3000 PSI at 28 days. (Per ACI-318-77)
3. Soil bearing capacity should be no less than 2000 PSF.
4. Concrete should be poured against undisturbed soil.
5. Allow concrete 24 hours set time before installation of antenna.
6. The antenna should be properly grounded to meet applicable local codes.
7. Minimum depth as shown or extend to local frost line.
8. Foundation meets the design requirements as set forth by the uniform building code. (1982 edition)

**(PRODELIN CORPORATION DOES NOT REPRESENT OR WARRANT THAT ANY PARTICULAR DESIGN OR SIZE OF FOUNDATION IS APPROPRIATE FOR ANY LOCALITY OR EARTH STATION INSTALLATION.)**

**SECTION II      REFLECTOR AND SUPPORT ASSEMBLY**

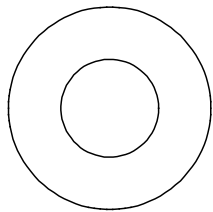
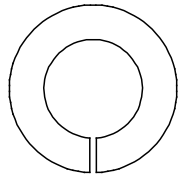
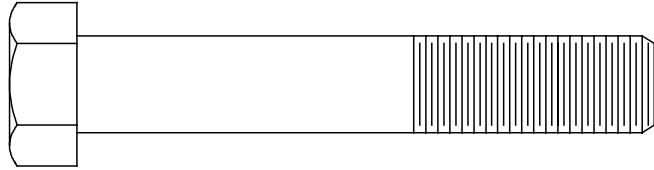
<b>REFLECTOR AND SUPPORT ASSEMBLY PART LIST- TABLE 2.0</b>			
<b>ITEM</b>	<b>PART NO.</b>	<b>DESCRIPTION</b>	<b>QTY</b>
1	VARIES	2.4M Reflector Petals	4
2	0181-278	2.4M Tracking Mount assembly	1
3	0181-294	Azimuth Actuator / Gimbal Assembly, 18"	1
4	0181-279	Elevation Actuator / Gimbal Assembly, 36"	1
5	0181-990	Back Frame	1
6	0181-182	Major Template Assembly	1
7	0181-183	Minor Template Assembly	1
8	0159-265	Threaded Insert	4
9	8201-033G	Green 1/2" Wide washer	4
10	8201-043	1/2" Flatwasher	6
			
11	8202-043	1/2" Lockwasher	6
			
12	8033-061	1/2"-13 x 9.00 Bolt	4
			

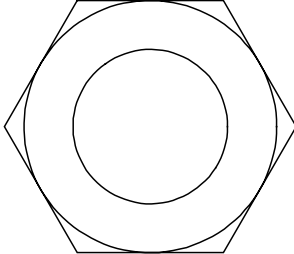
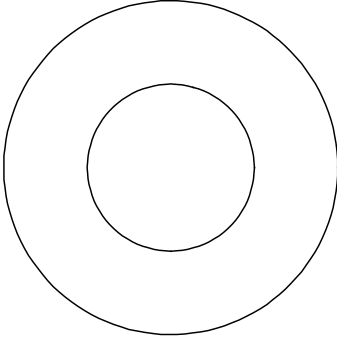
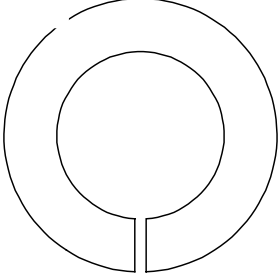
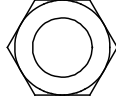
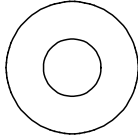
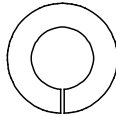
PARTS LIST - CONTINUED			
ITEM	PART NO.	DESCRIPTION	QTY
13	8110-007	7/8" Hex Nut 	4
14	8201-052	7/8" Flatwasher 	4
15	8202-052	7/8" Lockwasher 	4
16	8101-009	5/16" Hex Nut 	12
17	8201-041	5/16" Flatwasher 	84
18	8202-041	5/16" Lockwasher 	12

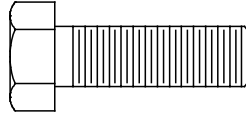
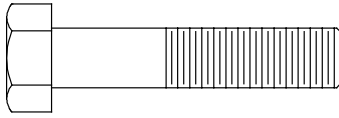
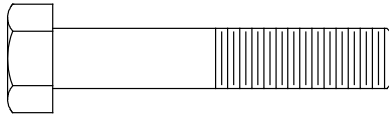
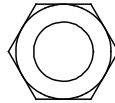
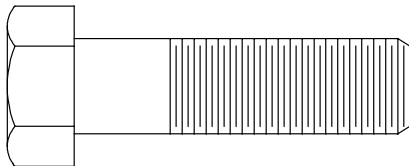
<b>PARTS LIST - CONTINUED</b>			
<b>ITEM</b>	<b>PART NO.</b>	<b>DESCRIPTION</b>	<b>QTY</b>
19	8031-008	5/16"-18 x 1.00 Bolt 	8
20	8031-012	5/16"-18 x 1.50 Bolt 	4
21	8031-014	5/16"-18 x 1.75 Bolt 	20
22	8101-005	5/16" Nylon Hex Nut 	20
23	8033-014	1/2" -13 x 1.75 Bolt 	2

**CAUTION:** During the assembly procedure, the sequence of instructions must be followed. **Do Not Tighten Any Hardware Until Instructed.** Refer to the antenna assembly parts list and the following steps.

**2.1 DUAL AXIS TRACKING MOUNT INSTALLATION**

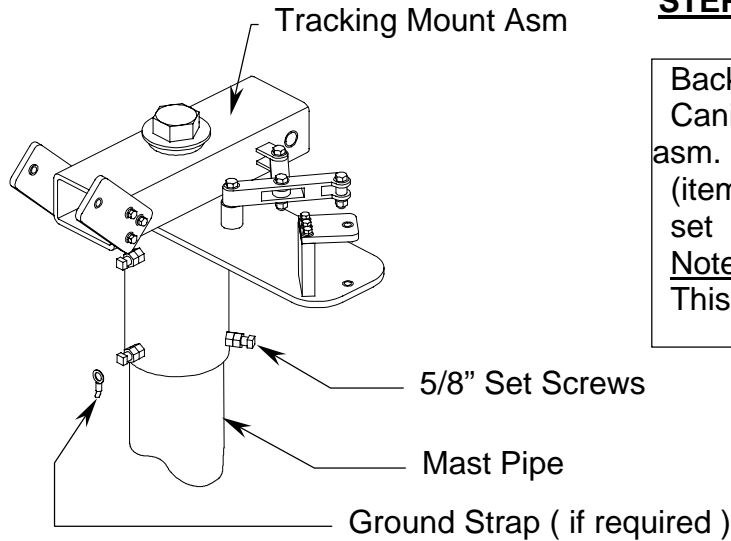

**STEP 1:**

Back out the [6] 5/8" set screws from the Canister and slip the tracking mount asm. (item 2) over the mast pipe. Tighten the set screws snug against the mast pipe. Note, a ground strap can be attached at This stage to one of the set screws.

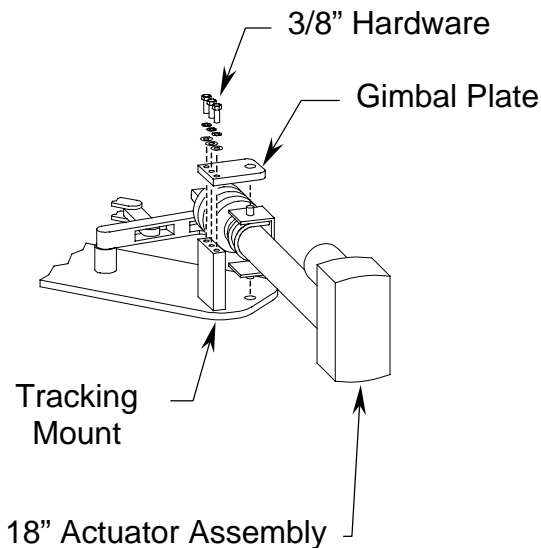

**STEP 2:**

- A) Remove the 3/8" hardware and the gimbal mount plate from the tracking mount.
- B) Install one post of the 18" actuator (item 3) into the hole in the bottom plate of the tracking mount. Note that the arrow located on the actuator motor must point up.
- C) Re install the gimbal mounting plate. Be sure that the bearing face on the plate is towards the gimbal. Note that the actuator/gimbal assembly is pre-set at the factory and needs no adjustment.

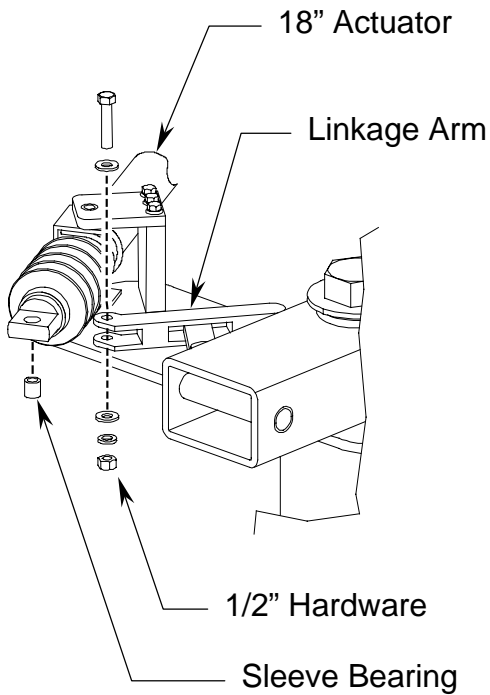
**STEP 3:**

- A) Remove the 1/2" hardware and sleeve bearing from the tab on the end of the azimuth linkage on the tracking mount.
- B) Slide the bearing sleeve through the swivel ball on the end of the 18" actuator.
- C) Move the actuator so that the holes in bearing and linkages arm are in line with each other.
- D) Reinsert the 1/2" hardware and tighten until the lockwasher is flat. Then tighten another half turn.

## **2.2 REFLECTOR QUADRANT ORIENTATION**

The 4-PC 2.4M reflector quadrants are labeled #1, #2, #3 and #4. These numbers may be found molded into the back of each quadrant at the inside corner. Note that each quadrant has a longer side (major axis) and a shorter side (minor axis). In the standard upright position, the antenna elevation angle range is between 12 and 90 degrees. When viewed from behind in the standard position (feed support at the bottom), quadrant #1 should be in the upper left; #2 is lower left; #3 is lower right and #4 in the upper right position. See Figure 1.

However, to allow a lower profile installation or in areas of high snow accumulation, the reflector can be assembled in the inverted position (feed support at the top). In this position, quadrant #1 would be in the lower right; #2 upper right; #3 in upper left and #4 in lower left position. See Figure 2.

When assembling for the inverted position, the Back Frame (item 5) must be turned 180 degrees from its standard position prior to its mounting to the Az/EI positioner – see Step 7.

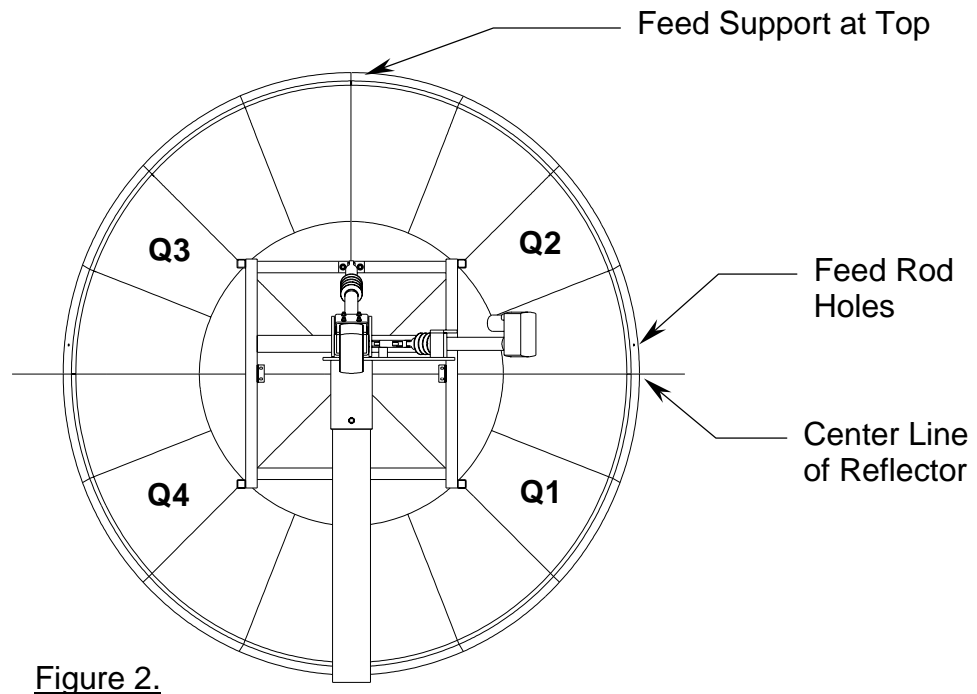
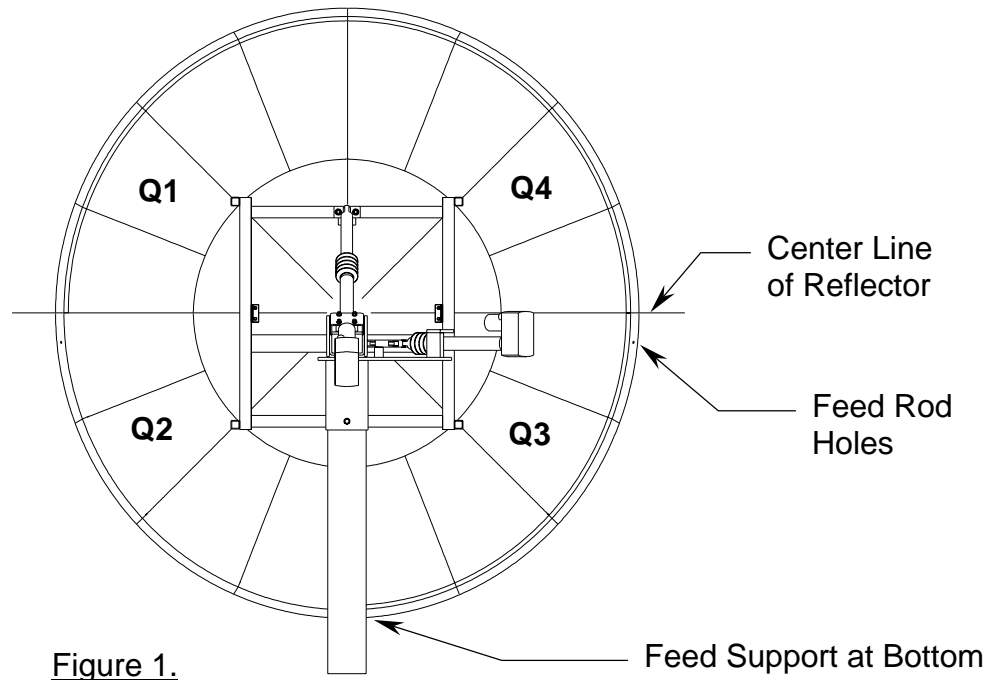

### 2.3 REFLECTOR SUPPORT ASSEMBLY

**WARNING!** The reflector support frame includes a precision alignment feature. Do not drop or drag the frame during the installation process. Do not attempt to adjust the round tube spacers in the frame assembly, as these are factory pre-set. If these spacers are loose or damaged, or there is any obvious damage to the frame, then you must obtain replacement parts for a successful installation.

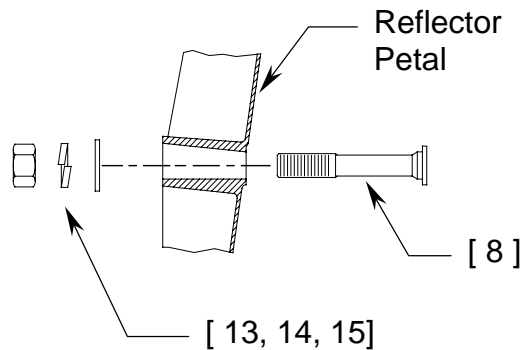

**STEP 1:**

Locate quadrant #1 and insert threaded insert (item 8) thru the hole on the face of the reflector. Secure insert with 7/8" hardware (items 13, 14, 15). Snug only to allow freedom of movement for the back frame assembly. Repeat step for quadrants #2, #3 & #4.

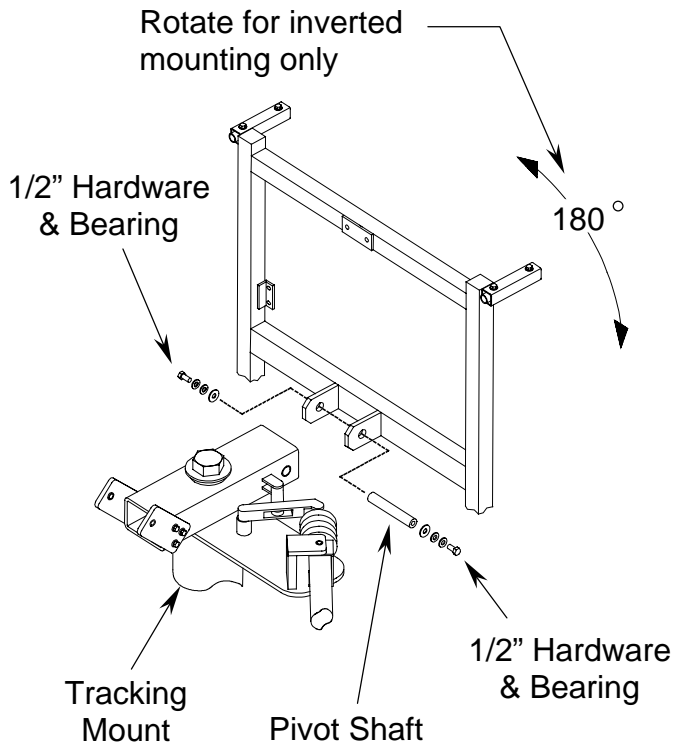

**STEP 2:**

- Remove the 1/2" hardware, bearings and pivot shaft from the back frame assembly (item 5).
- Straddle the tabs of the back frame over the holes in the end of the azimuth tube on the tracking mount. **Note:** For inverted mounting, rotate the frame 180 deg.
- Insert the pivot shaft thru the aligned holes. Replace the two bearings on the tabs then secure the assembly with the 1/2" hardware.
- Tighten snug and let the back frame fall back upon the tracking mount.

**STEP 3:**

- Place the major template assembly (item 6) on the back of the frame with the letters "MAJ" pointing towards the top of the frame (top being where the positioner is closest to the elevation tab).
- Insert the 5/16" bolts (item 19) thru the angles in the frame and into the angles on the template. Secure with 5/16" hardware (items 16, 17, 18). Snug hardware but **do not tighten**.

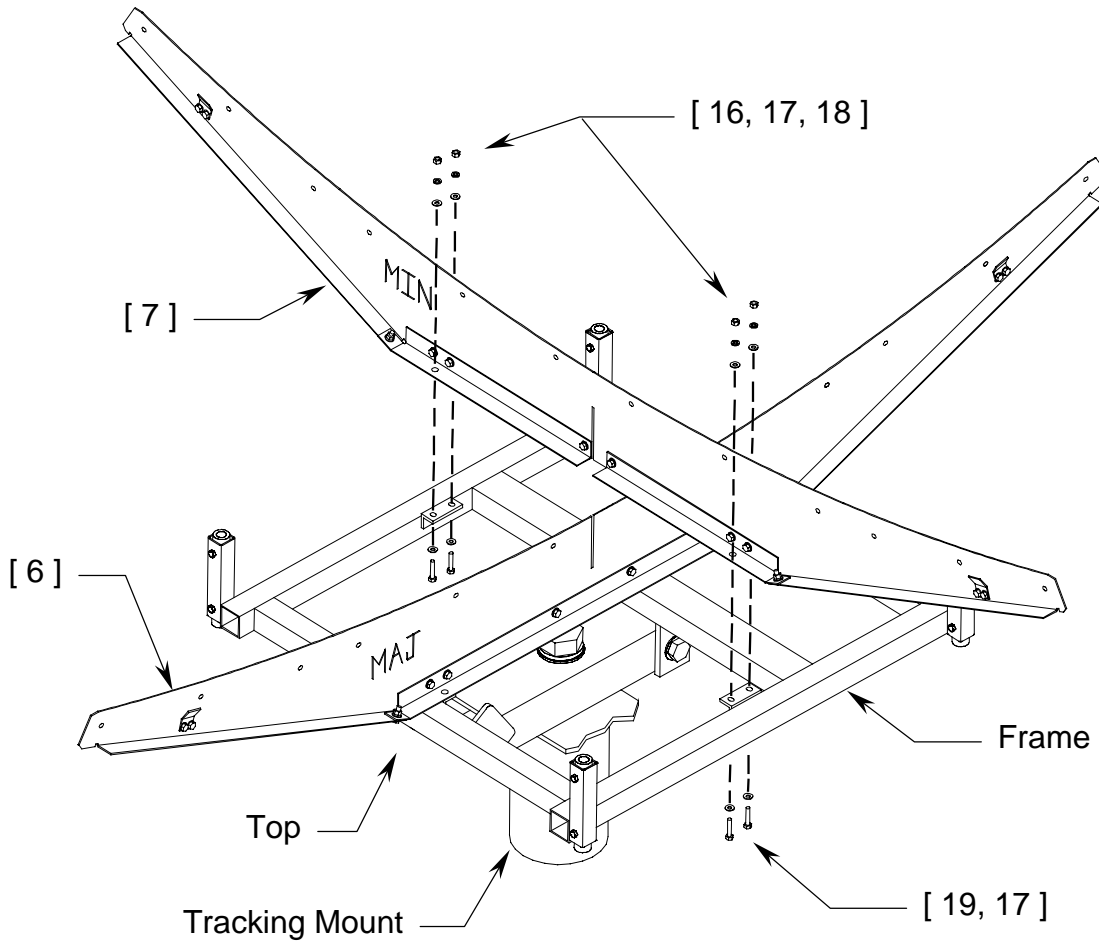

**STEP 4:**

16

- A) Lift Quadrant #1 over the templates as shown. Note that the longer side of the quadrant should be aligned along the major axis.
- B) Lower the quadrant between the templates and let it rest upon the

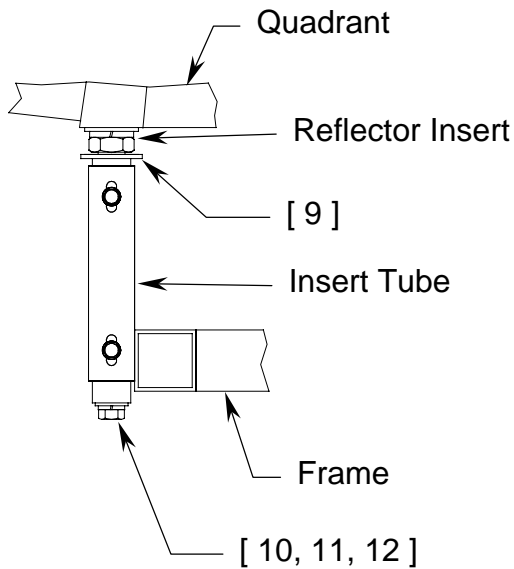
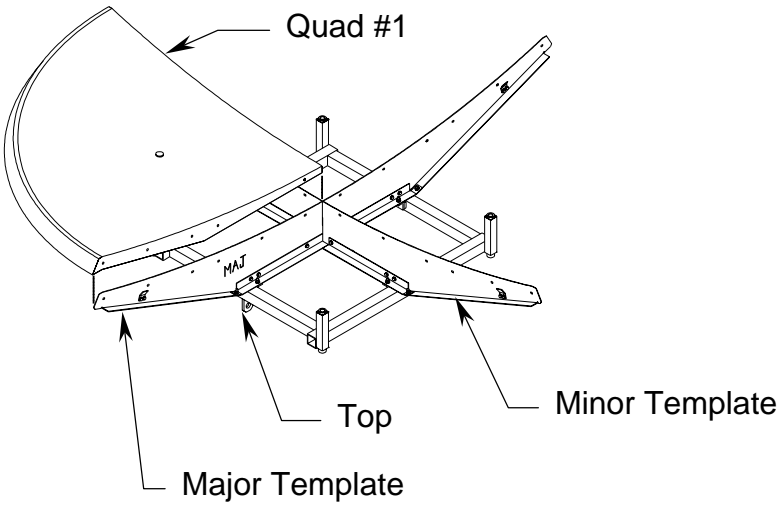

**STEP 5:**

- A) Slip a green washer (item 9) between the insert tube on the frame and the reflector insert on the quadrant.
- B) Insert the 1/2" x 9" bolt and hardware (items 10, 11, 12) into the bottom of the insert tube, thru the green washer and into the reflector insert. Snug the bolt but do not tighten.
- C) Repeat steps 4 and 5 with the three remaining quadrants.

**STEP 6:**

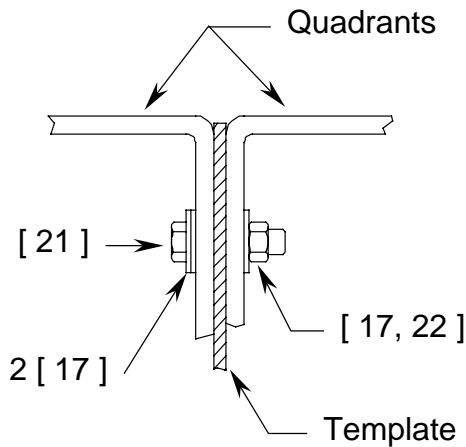
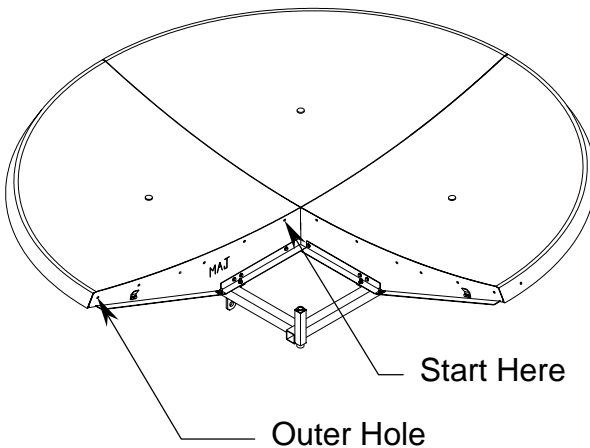

A) Working from the center out, place two 5/16" flatwashers (item 17) under the head of the 5/16" x 1.75" bolt (item 21). Insert bolt thru the holes, place another flatwasher and thread a nylon lock nut (item 22) onto end of bolt and tighten. Leave the outer four holes open. **NOTE: once the nut is tight, the bolt will still be loose. DO NOT add washers or change the bolt length.**

B) For the four remaining holes closest to the outer rim, secure with 5/16" x 1.50 bolt and hardware (items 20, 16, 17, 18). Tightening these last bolts will clamp the petals together – desired result.

C) Now return to where the templates are attached to the frame and securely tighten the eight pieces of hardware.

D) Next tighten the four 1/2" bolts going thru the insert tubes and into the reflector inserts.

E) Now tighten the 7/8" hardware on the reflector inserts that run thru each quadrant. **Do not tighten all at once.** Alternate between the inserts, tightening a little at a time. Follow this pattern until the lockwashers are flat. Be careful not to over tighten as this will damage the boss on the quadrant.

36" Actuator Assembly

**STEP 7:**

- A) Remove one of the elevation gimbal plates from the azimuth tube on the tracking mount.
- B) Insert one post of the 36" actuator gimbal

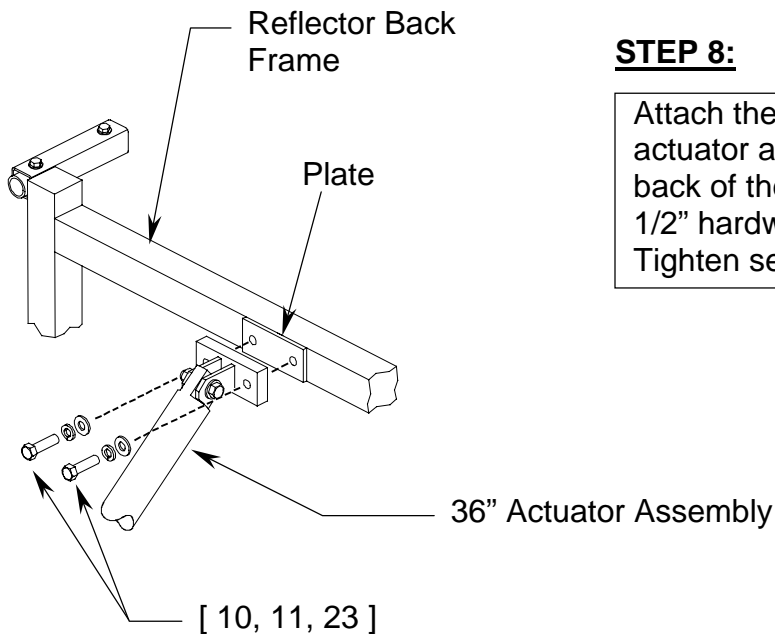
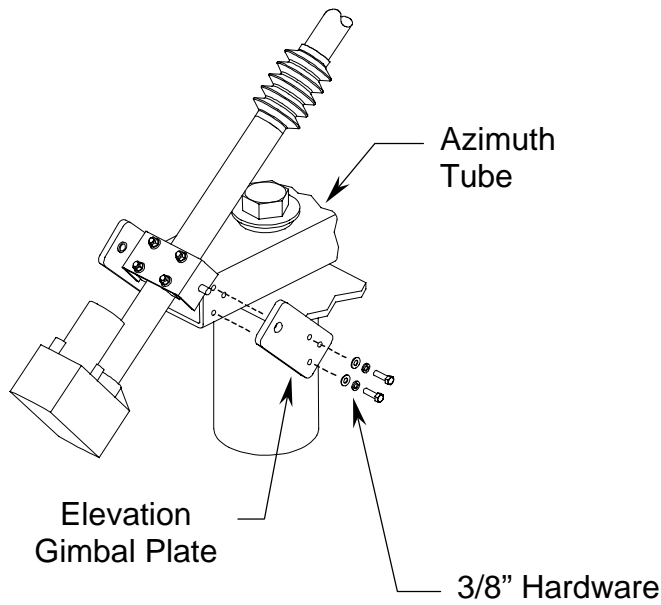

**STEP 8:**

Attach the opposite end of the 36" actuator assembly to the plate on the back of the reflector back frame with 1/2" hardware (items 10, 11, 23). Tighten securely.

**SECTION III      FEED SUPPORT ASSEMBLY**

The following instructions cover the installation of a typical 2.4M feed system onto the Prodelin 4 pc 2.4M antenna. For details concerning the specific feed and ODU

installation, refer to the instructions packaged with the feed system. Refer to the part list below and the following steps.

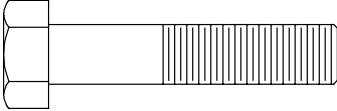
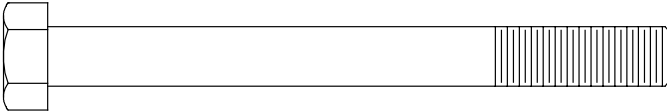
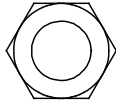
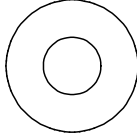
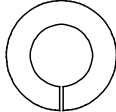
FEED SUPPORT PART LIST – TABLE 3.0			
ITEM	PART NO.	DESCRIPTION	QTY
1	Varies	Feed Rod	2
2	Varies	Feed Support	1
3	8031-012	5/16"-18 x 1.50 Bolt 	4
4	8031-026	5/16"-18 x 3.25 Bolt 	1
5	8101-009	5/16" Hex Nut 	5
6	8201-041	5/16" Flatwasher 	10
7	8202-041	5/16" Lockwasher 	5

**3.1 FEED SUPPORT ASSEMBLY**

**STEP 1:**

Attach the long end of each feed rod (item 1) loosely to the sides of the reflector with 5/16" hardware (items 3, 5, 6, 7). See detail A

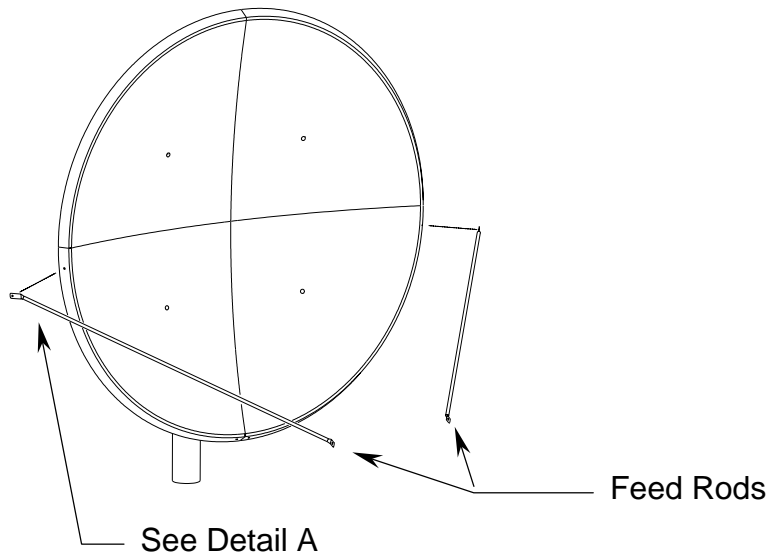

**STEP 2:**

Position the feed support (item 2) in front of the reflector as shown and attach to the to ends of the feed rods with 5/16" hardware (items 4, 5, 6, 7).  
See Detail B.

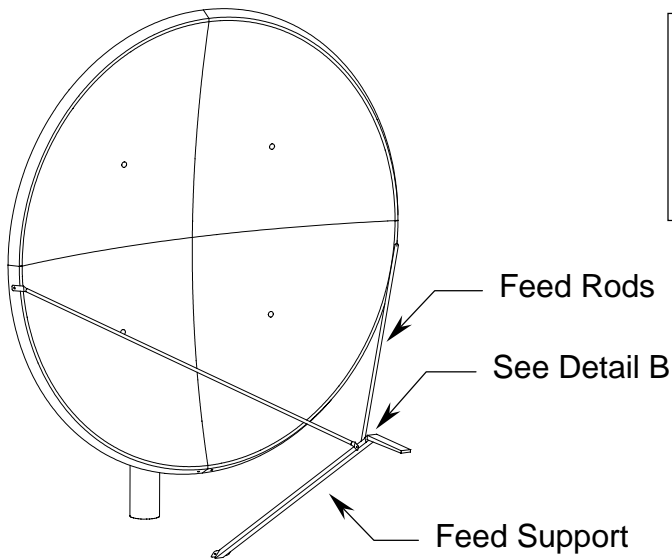

**STEP 3:**

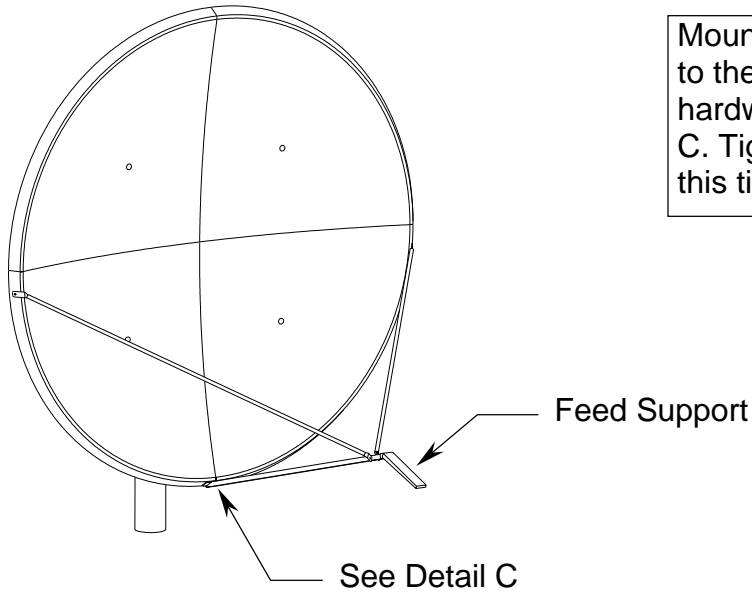

Mount the other end of the feed support to the bottom of the reflector with 5/16" hardware ( items 3, 5, 6, 7 ).See Detail C. Tighten all feed support hardware at this time.

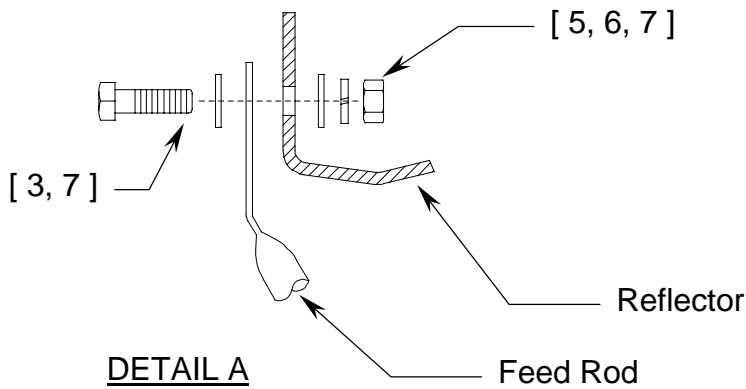

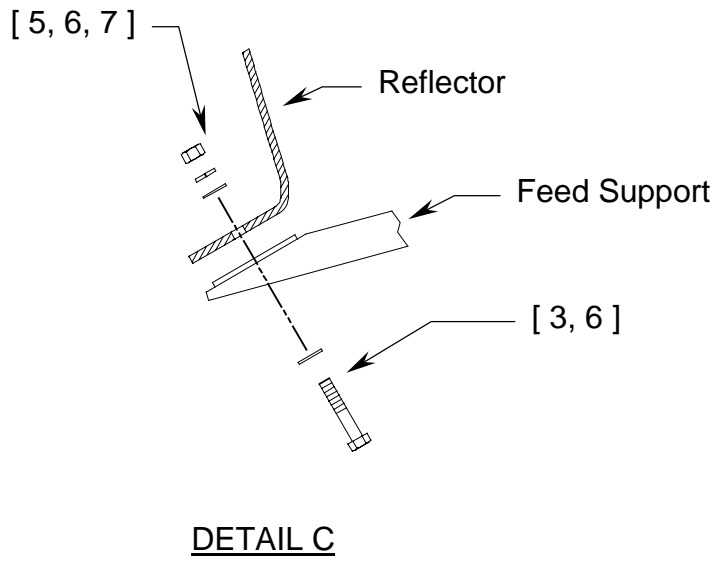
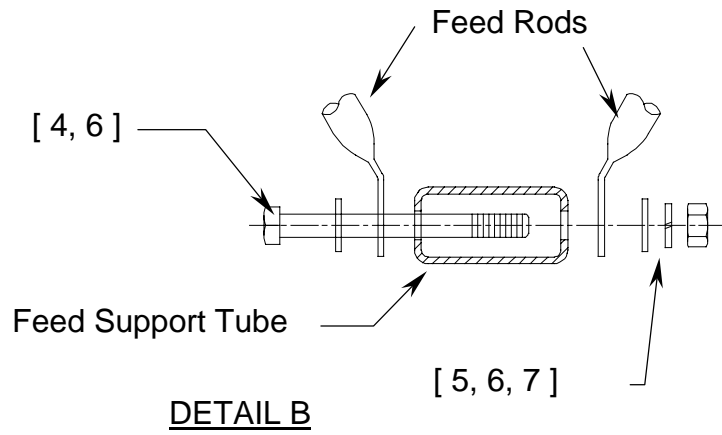

**SECTION IV**

**ANTENNA TRACKING CONTROLLER SET-UP**

**4.0 ANTENNA CONTROLLER UNIT SET-UP**

Prodelin recommends referring to the manual included with the controller for wiring and set-up instructions.

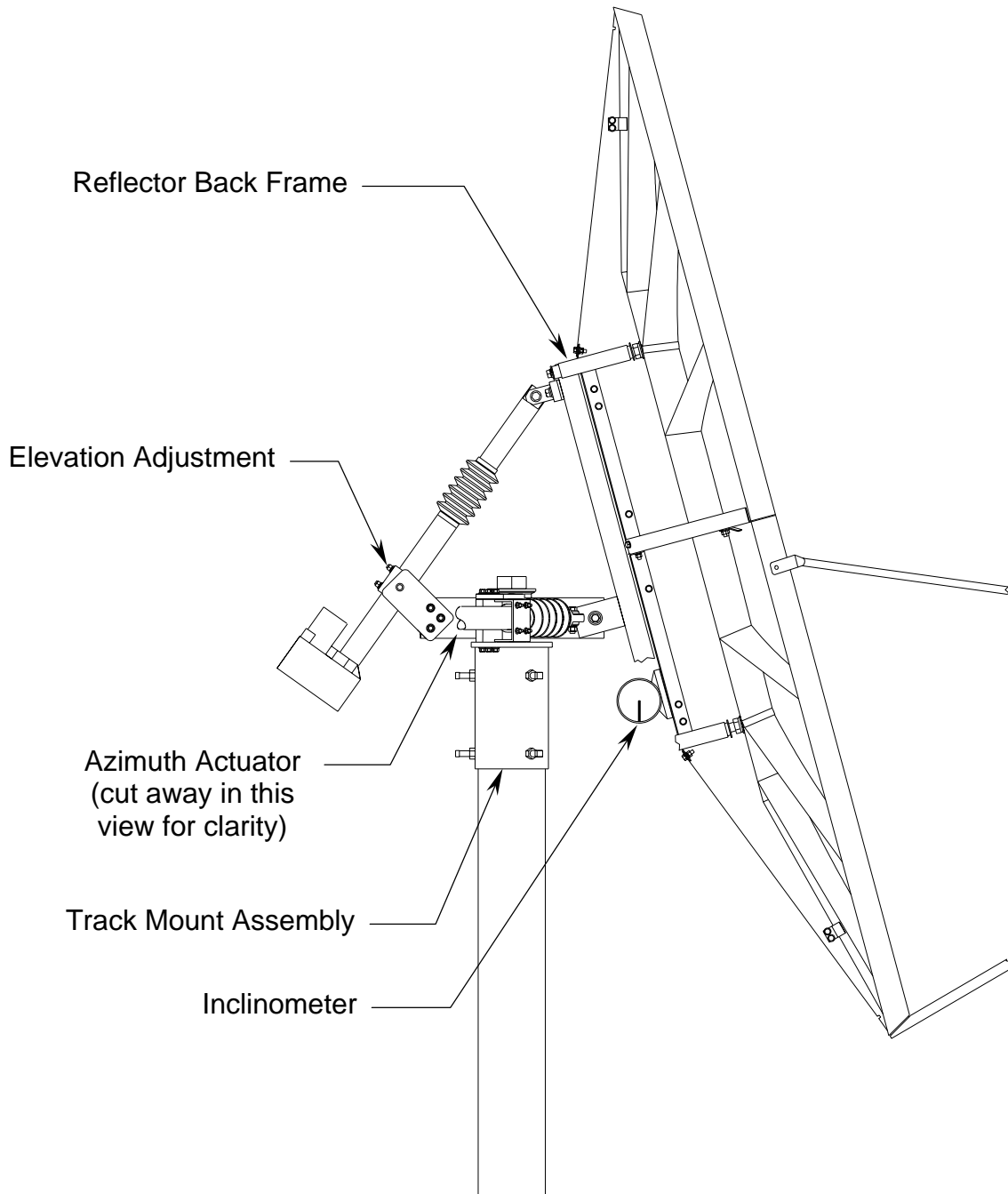

Figure 5

---

**SECTION VI      MAINTENANCE****5.0      MAINTENANCE OVERVIEW**

After installation, the antenna requires only periodic inspection. It is anticipated that maintenance, if required, will be minimal and easily handled by a local or in-house maintenance staff. The materials used in the construction of this Earth Station Antenna virtually eliminate any maintenance repairs.

**5.1      PERIODIC INSPECTION**

It is suggested that a periodic inspection be performed at least every six months.

NOTE: After any very severe weather conditions, inspection of the antenna should be performed to determine if foreign objects have caused damage or if survival specifications have been exceeded.

This inspection should include the following:

- 1)      Check all bolting locations - all bolts should be tight.
- 2)      Check all structural members - repair or replace if damaged.
- 3)      Check the foundation anchor bolts - they must be secure and with no failure signs in foundation.
- 4)      Check for corrosion - on the reflector structure and mount.

**5.2      REFLECTOR**

Prodelin's reflector does not require any maintenance. The composite construction of the reflector is virtually impervious to any damages that could be caused by weather or other atmospheric conditions.

It is only necessary to inspect for any physical damage done by vandalism or very severe weather conditions.

Should any damage be detected to a portion of the reflector, contact the Customer Service Department at Prodelin for recommendations involving reflector repair.

**5.3      MOUNT AND REFLECTOR SUPPORT STRUCTURE**

The mount and reflector support structure supplied with this antenna is of steel construction and has a hot-dipped galvanized finish.

If inspection shows any signs of structural failure, the mount members that are damaged should be repaired or replaced.

Corrosion: Any corrosion on steel members may be repaired with a cold, zinc-rich galvanizing paint.

#### **5.4 FEED AND FEED SUPPORT**

The feed support system should be inspected to insure that all hardware is secure. The feed/radio mounting bolts should be tight.

The feed horn window should be inspected to insure that it is intact so that no moisture can collect inside the feed horn. Replace if damaged.

#### **5.5 BEARINGS**

The bearings should be lubricated every six months by spraying a light oil on the bearings and allowing the oil to saturate onto the bearing.

#### **5.6 ACTUATORS**

The actuators are designed to provide years of maintenance free service. Although it might be a good to remove the motor housing covers and spray a light oil on the gears of the limit switches.

## Chapter 1 INTRODUCTION

The RC2000C AZ/EL tracking antenna controller is designed to control an elevation over azimuth antenna with 36-volt actuators and pulse type position sense feedback. Another member of the RC2000 family, the RC2000C Polar, is available to provide tracking for a modified polar mount antenna. Henceforth, in this manual the term RC2000C is used to refer to the RC2000C AZ/EL controller.

The RC2000C was designed with the requirements of the commercial user of satellite downlink services in mind. Here is a brief listing of the capabilities of the RC2000C.

1. The controller utilizes a solid state drive system capable of providing 8 amps to the antenna actuators. The drive system has built-in over-current sensing with mechanical relay backup to disconnect the drive from the actuators in the event of a fault.
2. The controller can control polarization via a polarotor type interface. The AUTO\_POL feature allows the polarization to be controlled via a digital input or contact closure supplied by a receiver to the RC2000C. An RC2KPOL option is available to provide control for a Seavey type two or four port feed with pot feedback.
3. Position sensing feedback can be supplied by any pulse-based sensor - reed switch, Hall effect, or electro-optical. There is no need for special sensors or actuators. The RC2000C keeps track of both rising and falling pulse edges from the pulse sensor for increased accuracy.
4. The non-volatile memory can hold position and polarization data for 35 satellites, five of which may be inclined orbit.
5. The Adapti-Drive variable speed control system allows the user to specify the desired slow speed for each axis. The Adapti-Drive system will then adjust the actuator voltage (via a pulse width modulation scheme) to maintain the speed selected by the user. This alleviates the problem of poor speed regulation with varying direction along a given axis associated with constant voltage slow speed systems.
6. The RC2000C is equipped with an RS-422 communications port. This allows the controller to interface with a PC. The communication protocol used is compatible with the popular SA-Bus protocol. Two IBM PC compatible programs, rc2kc.exe and rc2kdemo.exe are included with the controller, on a floppy disk in the back of this manual. The optional AUTOPILOT software package allows a single PC to control multiple antenna positioners and satellite receivers. An optional RS-232 to RS-422 interface converter, designated RC1KADP, is available to convert the RS-232 interface (which is standard on PC's) over to the RS-422 interface required for the SA-Bus protocol used on the RC2000.
7. The tracking scheme used in the RC2000C employs a step track algorithm to build up a track table that logs the satellite position versus time (a real time clock powered by a lithium battery is present in the RC2000C). If the current time corresponds to a time interval for which there are valid entries in the track table, the controller switches over to a program track algorithm. In this mode the antenna smoothly tracks the satellite based on position data stored in the track table.
8. If the satellite transponder goes down while the controller is step tracking, the controller enters a search mode. The RC2000C has a unique algorithm, denoted Intelli-Search, which determines the boundaries of a parallelogram shaped region where the controller has determined that the satellite will be found. This algorithm ensures that the region searched is large enough to include the motion of the desired satellite and is centered and oriented properly so that satellites adjacent to the desired satellite are not 'found' during the search. For transmit applications the Intelli-Search feature can be disabled.
9. The data that has to be specified by the user to configure the tracking system is straightforward. The user must specify the time and date, the latitude and longitude of the antenna, the longitude of each satellite (both geostationary and inclined orbit) programmed into the RC2000C, the maximum antenna tracking error (in dB), and the antenna size.

## 1.1 Organization of this Manual

This manual is divided into two broad parts, Installation and Reference. The Installation part of this manual is designed to familiarize the user with the controller and guide him or her through the installation and configuration of the controller. The Reference portion of the manual gives a detailed description of all of the features and capabilities of the controller.

The Installation portion of the manual is comprised of Chapters 2 through 4. Chapter 2 explains the user interface and the basic operation of the unit. Chapter 3 guides the user through the physical installation and wiring of the unit as well as the initial software configuration. Chapter 4 covers all aspects of tracking inclined orbit satellites. It begins with a brief discussion of some of the theoretical aspects of the inclined orbit, and continues with a description of the algorithms used by the RC2000C for tracking inclined orbit satellites. Chapter 4 concludes with a step by step procedure that guides the user through the entry of track parameters and the initialization of a track on an inclined orbit satellite.

The Reference portion of this manual is comprised of chapters 5, 6, and 7 as well as the appendices which follow. These chapters of the manual describe the fields on the screens that the user will encounter, as well as the data that can be entered at any prompt. After the initial installation, when the user has become familiar with the operation of the controller, these chapters will probably be the only ones consulted by the user to handle the routine chores of adding new satellites and deleting old ones.

## 1.2 Before You Begin

Please read and understand the manual. Time invested in understanding the installation and operation of the controller will insure satisfactory results. The unit has been tested thoroughly and will work accurately and reliably if it is installed and configured properly. There is an old saying in the controller business - "Garbage in, garbage out". Be very careful when entering data into the controller. For example, if the longitude data for a geostationary satellite is entered incorrectly, the controller will accurately position itself on that satellite. If, however, at a later time, a track is initiated on an inclined orbit satellite in the vicinity of that geostationary satellite, the incorrect longitude may be used to calculate incorrect step track angles and unsatisfactory results will occur.

## Chapter 2 BASIC FUNCTION DESCRIPTION

This chapter describes the controller's front panel layout, user interface and basic operation. When the user has completed this chapter, he or she should have a basic understanding of the various operating modes of the unit, and be able to use the keyboard and liquid crystal display (LCD) to navigate through those modes.

### 2.1 Front Panel

The front panel (figure 2.1) of the RC2000C contains an ON/OFF switch, a 2 row by 40 column backlit LCD, and a 4 by 4 matrix keypad with tactile feedback. An AC line circuit breaker is built into the ON/OFF switch, and a 12-amp circuit breaker (located on the back of the unit) protects the controller's 36-volt actuator drive circuits. When a circuit breaker of this type trips, it will protrude from its mounting bezel. To reset a circuit breaker, turn the power switch off, wait a few minutes for the circuit breaker to cool down, then depress the breaker so that it latches and is even with the bezel.



**Figure 2.1 - RC2000 Front Panel**

The field in the upper right hand corner of the LCD is reserved for the display of the current mode of the controller. The various modes are introduced in the following section. If an error condition is active, an error message will periodically flash across the bottom row of the display. Error messages are discussed in chapter 7. Chapter 5 explains the contents of every field on the display for all of the various controller modes.

An examination of the keyboard in figure 2.2 reveals that many of the keys have 2 or more labels. The function of each key is determined by the current operational mode of the controller. The various modes are discussed in the following section.

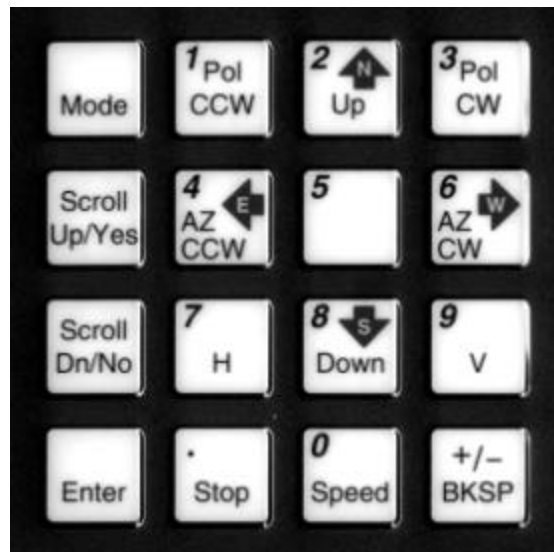

**Figure 2.2 - RC2000 Keypad**

**MODE**

This key allows the user to change the controller's current mode. Modes are used to access the various functions of the controller. For example, when MANUAL mode is active the user can manually jog the antenna; when SETUP is active the user can program satellite position data into the controller's non-volatile memory. The modes are divided into two groups: Operational Modes (which include MANUAL, AUTO, REMOTE, and TRACK modes) and Programming Modes (which include SETUP, DELETE, RESET, RESYNC, CONFIG and LIMITS modes). To change from one GROUP to the other DEPRESS THE MODE KEY FOR AT LEAST FIVE SECONDS AND THEN RELEASE IT. To toggle between the modes in a given group rapidly depress and release the mode key.

**SCROLL UP, SCROLL DOWN**

These keys are used to scroll up or down through a list of items. These keys are used when selecting a satellite from a list of satellites, selecting a data item to either view or modify, and when selecting alphanumeric characters for a user specified satellite name in SETUP mode.

**YES, NO**

These keys are used to supply an answer to a YES or NO type question.

**ENTER**

This key is used to select an entry from a list, terminate a prompt for some action by the user, or to complete the entry of numeric data.

**0-9, DECIMAL POINT (with the STOP key), BKSP**

These keys are used for numeric entry. The BKSP key causes the cursor to move one column to the left writing over the character that was there. In some modes, the BKSP key is used to prompt the user to confirm that a critical parameter is about to be changed.

**SPEED**

This key toggles the Az/EI speed from fast to slow and vice versa.

**AZ CW, AZ CCW, UP, DOWN**

These keys are used to manually jog the antenna in certain modes. CW refers to clockwise and CCW refers to counter clockwise. The sense of azimuth rotation is as seen by an observer located above the antenna. On early versions of the controller the AZ CW, AZ CCW, UP, and DOWN labels were not present on these keys. On these controllers (when certain modes are active) the left arrow key initiates CCW azimuth movement, the right arrow key initiates CW azimuth movement, the up arrow key initiates up elevation movement, and the down arrow key initiates down elevation movement.

**E, W, N, S**

These direction keys, E east, W west, N north, and S south specify a direction when the user is entering latitude or longitude data.

**POL CCW, POL CW, H, V**

These keys control the antenna polarization. The POL CCW and POL CW keys skew the polarization control device counterclockwise and clockwise. The H and V keys are used to either select or specify the polarization position associated with a given satellite. Note that not all versions of the software support a polarization control device.

**STOP**

During automatic moves this key may be used to halt the movement of the antenna.

Note that all of these keys are not active simultaneously. The function of each key is dependent on the current mode of the controller. In some modes certain keys are ignored.

## 2.2 Changing Modes with the MODE Key

The controller's current mode is always displayed in the upper right hand corner of the controller's display. The user can switch the current controller mode by use of the MODE key. The MODE key is always active - when the MODE key is depressed and released, the controller's current mode will change.

The modes are divided into two groups, referred to as mode groups. The Operational mode group consists of the MANUAL, AUTO, REMOTE, and TRACK modes. The Programming mode group consists of the SETUP, RESET, DELETE, RE-SYNC, CONFIG, and LIMITS modes. The Programming modes are typically only used during system installation and configuration. The Operational modes are the ones used in everyday operation of the controller.

To switch between modes in a group, rapidly depress and release the MODE key. To switch to a mode in the other mode groups, depress the MODE key for at least five seconds and release. Note that the Expert Access feature can prevent access to certain modes. See section 2.5 for more information on the Expert Access feature.

## 2.3 Mode Descriptions

The mode system on the RC2000C antenna controller resembles the menu system used with many personal computer (PC) programs. On a PC program a menu system allows the user to perform operations or to enter in data. The user must navigate through the menu structure to the particular menu that allows access to the function or data that the user wishes to manipulate. On the RC2000C the mode which is currently active is always displayed in the upper right hand corner of the LCD.

On power up, either MANUAL, TRACK or LIMITS mode will be active. If the unit powers up and the azimuth or elevation limits are invalid LIMITS mode will activate. If the unit powered down while tracking an inclined orbit satellite TRACK mode will receive control. For all other cases MANUAL mode will be active on power up.

Here is a summary of the modes implemented on the RC2000C ...

### MANUAL

```
AZ: 325 EL: 976 PL:50 H S:635 MANUAL
SAT:SBS 2 97.0 W FAST
```

In manual mode you can:

1. Jog the antenna in elevation and azimuth using the AZIM CW, AZIM CCW, ELEV UP, and ELEV DOWN keys.
2. Toggle the speed from fast to slow (and vice versa) with the SPEED key.

When MANUAL mode is active the following information is displayed on the top row of the LCD: azimuth position (AZ), elevation position (EL), and the current signal strength (SS). The signal strength is derived from an analog input in the controller's backpanel.

The bottom row of the LCD displays the name and longitude of the satellite that was the last target of an AUTO move, and either the FAST or SLOW banner to indicate the speed that will be used for jogging the antenna. When the antenna is being jogged at slow speed the voltage applied to the actuator is displayed to the right of the SLOW speed banner.

### AUTO

```
SELECT A SATELLITE: PANAMSAT-1 AUTO
USE SCROLL UP/DOWN, ENTER TO SELECT
```

This mode allows the user to automatically position the antenna on any satellite that has been programmed into memory. The list of programmed satellites is reviewed via the SCROLL UP/DOWN keys, and the ENTER key initiates the automatic move. The STOP key will terminate the move. When the antenna is positioned, the controller will switch to MANUAL mode for a geostationary satellite, or TRACK mode for an inclined orbit satellite.

### REMOTE

```
AZ: 325 EL: 976 PL:50 H S:635 REMOTE
SAT:SBS 2 FAST
```

In this mode the controller receives and acts on commands received via the communications port. This mode can only receive control if enabled via a CONFIG mode item. The only key that is active is the MODE key, which can be used to switch to a different mode.

SETUP

```
AZ: 325 EL: 976 PL:50 H S:635 SETUP
SAT:SBS 2 SELECT:GALAXY 9 FAST
```

This mode allows a user to associate a satellite name with an antenna azimuth and elevation position and to assign horizontal and vertical polarization positions to that satellite. The satellite name and the antenna position data associated with it are stored in non-volatile memory. Once stored in memory, the satellite is available for recall by AUTO mode. Note that not all versions of the software support polarization control.

When SETUP mode is first activated, the user can jog the antenna using the AZIM CCW, AZIM CW, ELEV UP, and ELEV DOWN keys. On controllers that support polarization control the polarization may be skewed using the POL CCW and POL CW keys. The user peaks the antenna on the desired satellite. The satellite name is selected using the SCROLL UP and SCROLL DOWN keys (the selected satellite name is displayed to the right of the SELECT: banner). If the desired satellite name is not available select the USER entry to manually enter a satellite name.

When the ENTER key is depressed the user is prompted to enter ...

1. the satellite longitude,
2. whether or not the satellite is in an inclined orbit (and if so, the satellite frequency band and the current inclination of the satellite's orbital plane to the earth's equatorial plane - more on this in the chapter on tracking), and
3. the horizontal and vertical polarization values for the satellite (on those versions of the software that support polarization control).

When the user has entered all of the requested data, the controller will respond with "DATA ACCEPTED", and the user can jog the antenna to another satellite and repeat the procedure. If the satellite just entered was an inclined orbit satellite, the controller will activate TRACK mode and will initiate a track on the satellite.

RESET

```
AZ: DRIVE EL: OK PL:SENSOR RESET
RESET AXIS: 1-AZ, 2-EL, 3-POL
```

This mode allows the user to examine the error status of the motor drive circuits and reset them if a fault has occurred. The drive systems of each axis are independent. A DRIVE error indicates that the drive circuits detected an over current fault and shut down. A JAMMED error indicates that the antenna actuators were commanded to move but no movement was detected. A RUNAWAY error indicates that antenna movement was detected when the actuators were not energized. A SENSOR error indicates backward movement of the polarization sense potentiometer. (Polarization errors will only be shown if the rotating feed drive option has been enabled.) An error condition for a given axis can be reset by depressing the numeric key associated with that axis as described on the bottom row of the display. Errors are described in chapter 7.

DELETE

```
SELECT A SATELLITE: PANAMSAT-1 DELETE
USE SCROLL UP/DOWN, ENTER TO SELECT
```

This mode allows the user to delete satellites from non-volatile memory. The SCROLL UP/DOWN and ENTER keys are active.

RE-SYNC

```
SELECT A SATELLITE: PANAMSAT-1 RE-SYNC
USE SCROLL UP/DOWN, ENTER TO SELECT
```

The antenna azimuth and/or elevation position can be corrupted by any number of causes (sensor failure, lightning strike, faulty shield connection, etc.). If there is an error in the position counts, the controller cannot properly position itself on the satellites stored in non-volatile memory, and the limits are not valid. In this situation, it is necessary to re-synchronize the controller's internal position counts.

To do this, the operator positions the antenna on a known geostationary satellite that has previously been stored in the controller's non-volatile memory (preferably a Ku band satellite, since the beamwidth of the antenna is narrower at Ku band than at C band). The user then activates RE-SYNC mode, and uses the SCROLL UP/DOWN keys to select the satellite name with which the antenna is currently aligned. When the ENTER key is hit, the controller's internal position counts for that satellite are initialized to the current position, and a corresponding adjustment is made to all other satellite positions across the arc.

## CONFIG

```
ANTENNA LATITUDE LL.L:45.0          CONFIG
TENTHS AFTER DEC. PT  ENT,BKSP,SCRL ^v
```

This mode allows the user to view and enter configuration data into the controller. This data is stored in non-volatile memory and is used to set certain parameters and enable or disable certain controller options. The following parameters and options are controlled or configured via data entered into the controller from CONFIG mode:

AUTOPOL, communication port parameters, simultaneous azimuth/elevation movement, time and date, Az/EI angle display parameters, Az/EI slow speed and movement control parameters, polarization options, Az/EI drive systems options, antenna parameters, tracking system setup and control parameters

In CONFIG mode, the SCROLL UP/DOWN keys are used to select the parameter to be viewed or modified. If asterisks are displayed in the parameter field, it means that the present value is invalid. It can be modified using the numeric keypad to key in a new value, followed by ENTER. (For the modification to take effect the numeric entry must be terminated with the ENTER key.) The message in the lower left-hand corner of the display gives the user data entry instructions.

## LIMITS

```
AZ: 5000 EL: 5000 SS1,2: 761, 512 LIMITS
7 - SET CCW LIMIT 9 - SET DOWN LIMIT
```

This mode allows the user to jog the antenna to any azimuth or elevation position without regard to any existing limits, and initialize the azimuth CCW and CCW limits and/or down and up limits. Note that the sense of the azimuth CCW and CCW limits is defined as seen by an observer located above the antenna. Once the limits are set the antenna cannot be moved (except in LIMITS mode) to a position that is not within the region defined by the down, up, CCW, and CW limits.

To set the azimuth limits, the user would first move the antenna to the desired Azim CCW limit, hit ENTER to set the limit, then move the antenna to the desired Azim CW limit and hit ENTER to set that limit. (Whenever the limits are reset, the CCW and down limits are initialized to a position count of 30.)

To the right of the SS1,2: banner the current signal strength on AGC channels 1 and 2 are displayed.

## TRACK

```
AZ: 1344 EL: 546 PL: 73 V S:621 TRAK K
GSTAR 3 PROGRAM IDLE 15.56.0-MENU
```

TRACK mode is activated to track an inclined orbit satellite. TRACK mode is slightly different than the other modes described above in that TRACK mode cannot be reached directly through the use of the MODE key. TRACK mode can be entered only via the SETUP, AUTO or REMOTE modes. TRACK mode is described in Chapter 4.

More detailed information is available concerning each of the modes described above in Chapter 5 of this manual.

## 2.4 Mode Access

Access to some modes is restricted in some circumstances. Here are the conditions that can restrict access to certain modes:

1. TRACK mode can only be entered via the AUTO, SETUP or REMOTE modes - it cannot be entered via the MODE key. When TRACK mode is active it is treated as if it were in the operational mode group. If TRACK mode is active and the user presses the MODE key, control will transfer to the MANUAL mode. If TRACK mode is active and the user holds the MODE key in for five seconds, control will transfer to SETUP mode.
2. REMOTE mode is only accessible when the Remote Mode Enable CONFIG mode item is set to 1. When enabled, REMOTE mode can be activated either via the MODE key or by the receipt of a command on the serial port. Note that most commands received via the serial port may be processed while TRACK mode is active.
3. The expert access system can restrict access to certain modes. The intent is to avoid corruption of the operating parameters by inexperienced personnel. The expert access system is described in the next section.

## 2.5 Expert Access

An Expert Access flag is maintained by the controller. The user can inspect and change the state of this flag via the CONFIG mode Expert Access item. When the flag is set (1) the user has access to all controller modes (subject to the state of the Remote Mode Enable flag described in the preceding paragraph). When the Expert Access flag is reset (0), the user only has access to the MANUAL, AUTO, REMOTE, RESET, and CONFIG modes.

The Expert Access flag also controls access to CONFIG mode items. When the flag is reset (0), the user only has access to the AutoPolEnable, Simultaneous Az/EI Enable, and Expert Access CONFIG mode items. The user can toggle the state of the Expert Access flag by entering a 5-digit code at the CONFIG mode 'EXPERT ACCESS' item. This 5-digit code is contained in a removable appendix at the end of this manual, to safeguard from any accidental corruption of operating parameters by inexperienced personnel. Note that the Expert Access flag is set whenever the controller's memory is cleared via the Reset System Data CONFIG mode item.

## 2.6 AutoPol

The AutoPol feature slaves the RC2000C polarization control to an output derived from a satellite receiver. The RC2000C has an AutoPol input accessible via connector J1 on the back of the unit. When the controller is operating in MANUAL, REMOTE, or TRACK modes, this input is monitored and the polarotor is controlled according to a digital level present at this input.

To configure the controller for AutoPol operation, the user must have:

1. a suitable output available on the satellite receiver that is connected properly to the AutoPol input of the RC2000C,
2. the polarity of the AutoPol input must be specified (from CONFIG mode), and
3. the AutoPol feature must be enabled (also from CONFIG mode).

When the polarity of the AutoPol input is specified, the user is informing the controller that a given AutoPol input level (high or low) corresponds to vertical polarization. Configuring the AutoPol system during installation is covered in more detail in chapter 3, and the CONFIG mode prompts which enable and specify the polarity of the AutoPol input are described in Chapter 4 in the CONFIG mode section.

## Chapter 3 INSTALLATION/SETUP

This chapter guides the installer through controller installation and the initial software setup process. The procedures outlined in this chapter cover the mechanical and electrical installation of the unit, the setup of optional polarization control devices, setting the azimuth and elevation limits, determining the azimuth and elevation slow speed parameters, and programming the geostationary satellites into non-volatile memory. The next chapter covers inclined orbit satellites.

### 3.1 Before You Begin

Before installing the unit the installer must ensure that the line voltage is correct, the controller's memory has been cleared, and that he or she is familiar enough with the mode system described in Chapter 2 to place the controller in any desired mode. All units are shipped from the factory with memory cleared, and a line cord appropriate for the line voltage selected.

If the line cord received with the unit is not appropriate for the power available at the installation site, the installer should check the controller to ensure that the proper line voltage has been selected.

The RC2000C can be configured to operate on either 115 VAC or 230 VAC. The AC input voltage the unit is currently configured for is displayed in a window located in the fuse holder. To change the AC input voltage selection, remove the fuse holder and reverse the jumper assembly (on which the '115' and '230' labels are located). Switch the power off at the front panel. Remove the IEC power cord from the back panel power entry module. With a small straight-blade screwdriver, remove the fuse drawer from the power entry module. With the same tool, remove the small plastic circuit card. Rotate the card so that the desired operating voltage will be displayed through the front of the fuse drawer and reinsert the card so that it firmly seats into the power entry module. Replace the fuse with one of the appropriate size for the new operating mains voltage. The fuse holder is designed to accommodate 1/4" by 1 1/4" fuses. If the RC2000C is configured for 115 VAC operation, use a 2-amp slow blow type fuse. If the RC2000C is configured for 230 VAC operation, use a 1-amp slow blow type fuse.

When the AC line voltage has been verified, and before any of the antenna wiring has been connected, the installer should become familiar with the controller's user interface. It is not necessary to understand every aspect of the controller's operation to install the unit, but the installer should be familiar with the mode structure of the RC2000C and be able to use the MODE key to place the controller in any of the modes described in Chapter 2.

When the unit is powered up, it should be verified that the controller goes to LIMITS mode ('LIMITS' displayed in the upper right hand corner of the LCD). Before the controller is shipped from the factory, the memory is cleared and the azimuth and elevation limits are invalidated. Whenever the unit is powered up and the limits are invalid, the controller automatically places itself in LIMITS mode. If the unit does not power up in LIMITS mode the installer should perform a system reset to place the controller into a known state before proceeding with the installation.

To perform a system reset:

1. Use the MODE key to place the controller into CONFIG mode ('CONFIG' displayed in the upper right hand corner of the LCD).
2. Use the SCROLL keys to bring up the Reset System Data screen. If the Reset System Data item does not appear, the Expert Access flag (see section 2.5) may need to be reset.

To inspect the status of the Expert Access flag, use the SCROLL DOWN key (while still in CONFIG mode) to bring up the Expert Access CONFIG mode item. If a 1 does not appear in the data entry field, enter the 5-digit code described in section 2.5 to toggle the Expert Access flag on. This will allow access to the Reset System Data CONFIG mode item.

3. At the Reset System Data screen enter the same 5 digit code followed by the ENTER key.

## 3.2 Mechanical and Electrical Installation

This section covers the mechanical and electrical installation of the unit. Use 4 10-32 mounting screws to secure the unit to a standard 19" rack. Please refer to figures 3.1, 3.2, and 3.3 for diagrams of the controller back panel and electrical connections.

In the course of installing the antenna, do not connect an auxiliary power source to the antenna actuators while the RC2000 is connected to the actuators. When the RC2000 is 'idle' the drive outputs are shorted together to implement a dynamic brake.

The following electrical connections must be made:

Azimuth and Elevation Motor Drive - 4 wires (2 for each axis)

These cables connect the controller to the azimuth and elevation motors. The conductors must be sized appropriately so that sufficient voltage is supplied to the motors. The voltage supplied to the motors will be the output voltage from the controller less the voltage drop caused by the resistance of the wires.

The output voltage of the controller is a function of the current supplied to the motors. The voltage drop in the wires connecting the controller to the antenna is determined by the wire size, the wire length, and the current supplied to the motors. Figure A-1 (appendix H) in the back of this manual shows the relationship between the controller output voltage and load current.

The following tables show the separation between the controller and the antenna which will result in 28 and 22 volts being applied to the antenna drive motors as a function of motor current and wire gauge. The tables take into account the controller output loading and resistive losses in the conductors.

Separation (in feet) between controller and antenna which will result in 28 volts being applied to the motors:

<b>Motor Current</b>	<b>Wire Gauge</b>			
	<b>16 (1.3 sq. mm)</b>	<b>14 (2.1 sq. mm)</b>	<b>12 (3.3 sq. mm)</b>	<b>10 (5.26 sq. mm)</b>
2 Amps	600	950	1500	2410
3 Amps	340	520	830	1350
4 Amps	220	340	550	880
6 Amps	90	140	230	340
8 Amps	30	40	70	120

Separation (in feet) between controller and antenna which will result in 22 volts being applied to the motors:

<b>Motor Current</b>	<b>Wire Gauge</b>			
	<b>16 (1.3 sq. mm)</b>	<b>14 (2.1 sq. mm)</b>	<b>12 (3.3 sq. mm)</b>	<b>10 (5.26 sq. mm)</b>
2 Amps	970	1530	2430	3930
3 Amps	580	920	1460	2370
4 Amps	400	640	1020	1650
6 Amps	220	340	550	880
8 Amps	120	190	310	500

A typical 36-volt actuator will draw 2 to 4 amps and will run at voltages down to about 12 volts.

Polarotor™ - 3 wires in a shielded cable.

A Polarotor™ is a servo type device used for polarization control. Note that not all versions of the controller support polarization control. The Polarotor™ requires minimum current, typically 18-22 gauge conductors are used.

Connect the Polarotor™ as shown in either figure 3.2 or 3.3. Shielded cable is required to minimize noise pickup.

**NOTE: Shielded cable is recommended for the Polarotor™ to minimize noise pickup. If a shield is used it must be connected to J1-9 on the back of the controller and must not be connected at the antenna.**

#### Azimuth and Elevation Position Sense

If reed switch sensors are used, each axis requires 2 wires in a shielded cable. If Hall effect sensors are used, each axis requires 3 wires in a shielded cable. Shielded cables are required to minimize noise pickup that can result in antenna positioning errors. Please refer to figure 3.2 for reed sensor connections and figure 3.3 for Hall Effect sensor connections.

**NOTE: Shielded cables are required for the position sensors. The shields must be connected to pins J1-4 or J1-6 on the back of the controller and must not be connected at the antenna.**

Position count errors due to improper use of the shield on the position sense lines is one of the most frequent problems encountered during the installation of the RC2000C. Here are the problems that are encountered:

1. A shielded cable was not used for the position sense wires.
2. The shield is not connected at connector J1 on the rear panel of the RC2000C.
3. The shield is connected to earth ground at the antenna. This results in ground currents flowing in the shield. The shield must not be connected to anything at the antenna. At the actuator terminal strip, it is a good idea to place heat shrunk tubing over the frayed foil shielding material, where the sensor cable insulation is removed.
4. The insulator on the sensor cable is broken and the shield is grounded to something. As in #3, this results in ground currents.
5. The sensor cable is spliced but the shield has not been spliced, or the shield is spliced but is also shorted to earth ground. This often occurs when the sensor cables are spliced at a terminal box near the antenna. The sensor interface cables must be shielded all the way to the actuator.

See the Operation Troubleshooting Tips section of Chapter 7 for more information on count problems.

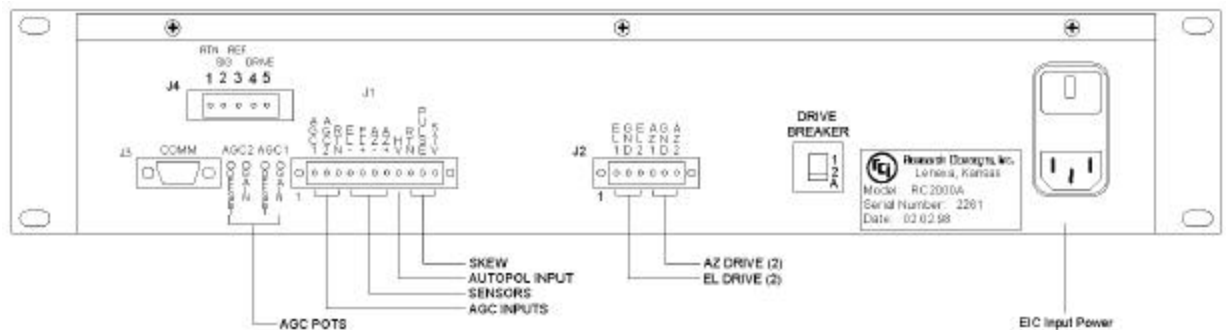

**Figure 3.1 - RC2000 Back Panel**

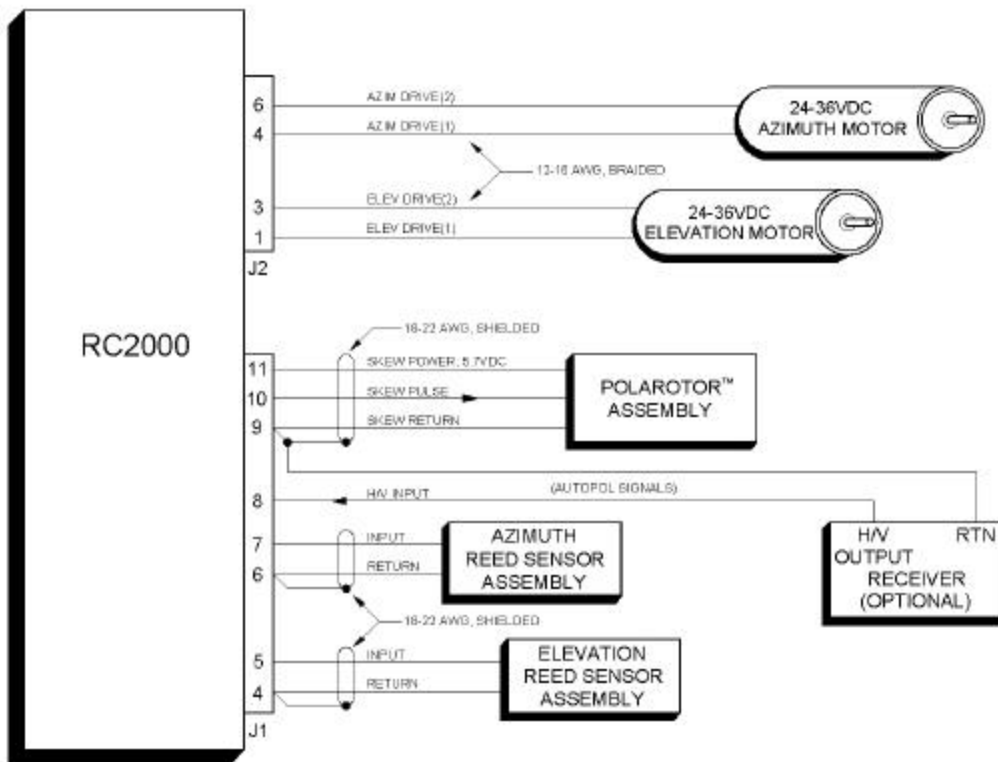

Figure 3.2 - Reed Sensor Interface

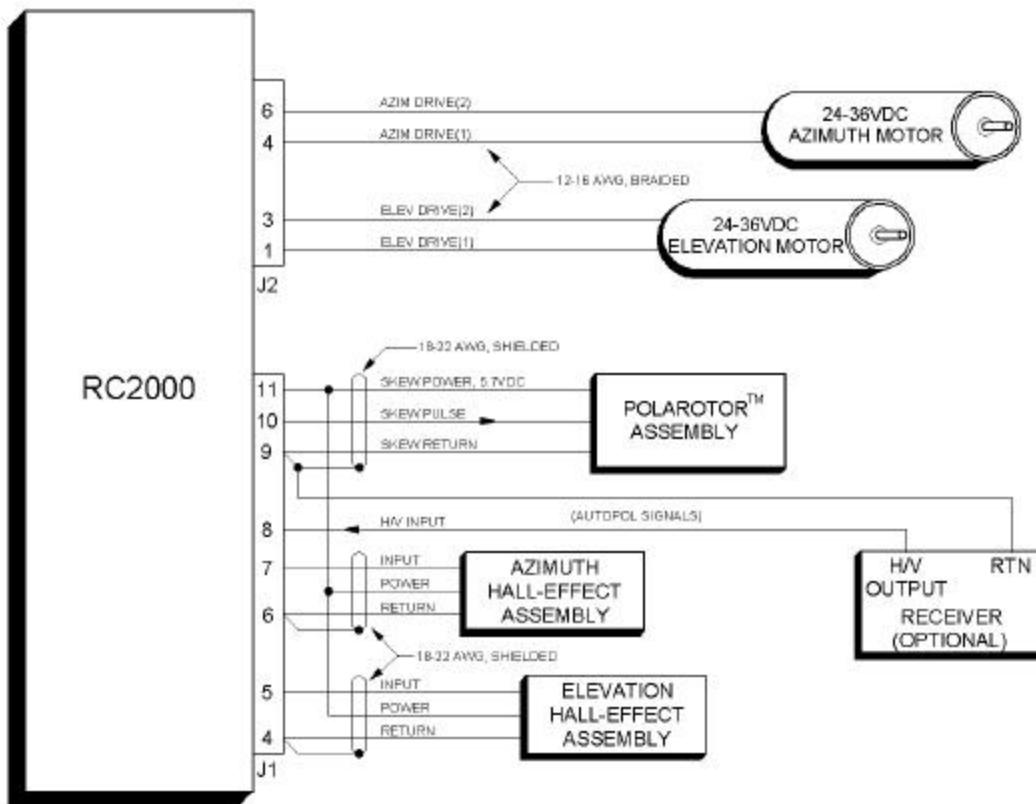

Figure 3.3 - Hall Effect Sensor Interface

### 3.3 Optional Polarization Control

With the RC2KPOL daughterboard option, the RC2000C can control a rotating feed which employs a 24-volt DC polarization motor with potentiometer position feedback. This section describes the installation and setup of a rotating feed compatible with the RC2KPOL option. It should be noted that not all versions of the controller support polarization control. If a polarization control device is not present or a Polarotor<sup>™</sup> is used, make sure that the Rotating Feed Present CONFIG mode item is set to 0 and proceed to the next section

**\*\*\* CAUTION \*\*\***

Before using a Seavey rotating feed with the RC2000, it is recommended that the user verify that the feed's range of mechanical movement is within the position sense potentiometer's range of mechanical movement. If the mechanical limit of the pot is reached before the mechanical limit of the feed is reached, the torque of the motor can destroy the pot. The pot used with the Seavey feed is a Spectrol model 533 (1K ohm, 3 turn) or a Contelec PD 2205-5KO/J (5K ohm, 5 turn). To see if the potentiometer is centered properly, the following procedure may be performed on a workbench.

#### Verifying Pot Center Position

1. Verify the total resistance of the potentiometer. This may be done by either reading the value written on the side of the pot, or by measuring between the two non-wiper terminals of the pot. For the Spectrol pot this will be terminals 1 and 3.
2. Connect an ohmmeter between the wiper of the pot (terminal 2 on the Spectrol or Contelec) and one of the other two terminals. Note that when the shaft position of the pot is near one of the pot's mechanical limits, the ohmmeter will read either less than 25 ohms, or the value found in step 1.
3. With a bench power supply, automobile battery charger, or some other voltage source, carefully apply power to the feed's DC motor to move it towards one mechanical limit or the other. (Note that the feed motor for the Seavey feed nominally requires 24 volts DC at approximately 150 mA. The feed motor should move with an applied voltage of 6 to 12 volts DC.)

While movement is in progress, monitor the ohmmeter to insure that the pot's mechanical limit is not reached. If the ohmmeter indicates that the pot's mechanical limit is being approached, quickly disconnect the power source and perform the procedure outlined in the section entitled "Centering the Pot".

4. If the feed can safely move to one of its mechanical limits, reverse the power supply leads and move the pot towards the other mechanical limit. Once again, monitor the ohmmeter to insure that the pot's mechanical limits are not exceeded. If the feed cannot be moved to its mechanical limit without approaching the pot's mechanical limit, perform the procedure outlined in the section entitled "Centering the Pot".

#### Centering the Pot

The procedure outlined here may be used to center the feed's range of travel within the pot's mechanical limits.

1. Find the total resistance of the pot. See step (1) above.
2. Loosen the allen screw that holds the shaft of the pot onto the gear.
3. Apply power to the feed motor (as in step (3) above) to center the feed in the middle of its range of travel. As the feed rotates, make sure that the shaft of the pot does not turn.
4. When the feed has been centered in its range of travel, connect the ohmmeter between the wiper and one of the other terminals of the pot. Rotate the shaft of the pot until the resistance read from the ohm meter is one half of the value of the pot's total resistance (obtained in step (1)).

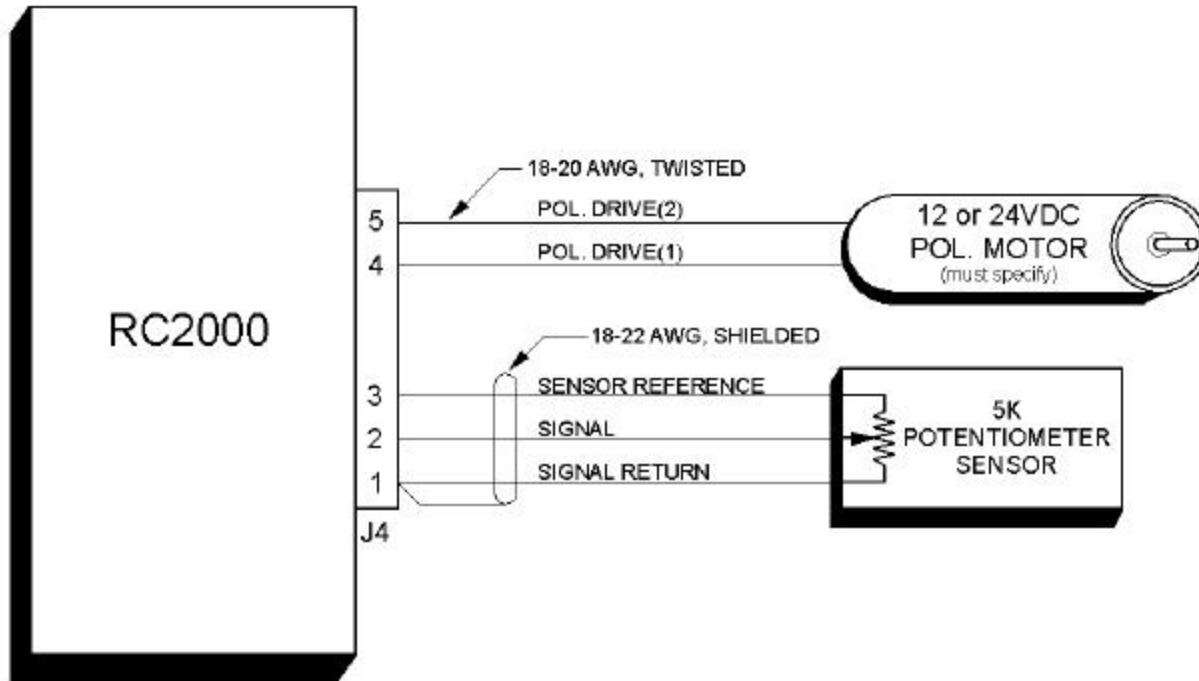

**Figure 3.4 - RC2KPOL Option**

5. Tighten the allen screw and verify that the pot is properly centered by performing the procedure above entitled "Verifying Pot Center Position".

Use the following procedure to configure the RC2000C for use with a 24V DC polarization motor.

1. Connect the polarization/sensor assembly as shown in figure 3.4. Note that shielded cable is recommended for the sensor connection. If a shielded cable is used the shield **MUST** be connected to the GROUND terminal (1) of connector J4 at the back of the controller and **MUST NOT** be connected to anything at the antenna. At the potentiometer use heat shrunk tubing to prevent foil shielding material from coming in contact with earth ground at the antenna
2. The CONFIG mode Rotating Feed Present item must be set to YES (1). Activate CONFIG mode and use the SCROLL DOWN key to bring up the Rotating Feed Present item and key in a 1 followed by the ENTER key. (If the Rotating Feed Present item is not accessible in CONFIG mode; the Expert Access flag has been reset. If this occurs, perform a system reset as described in section 3.1.)
3. In this step the polarity of the polarization motor and sensor wiring is checked. The motor polarity is somewhat arbitrary. The polarization jog keys are labeled POL CW and POL CCW. The user is free to define the direction sense as they wish. To change direction of motor rotation associated with CW and CCW, swap the motor drive wires attached to connector J4 terminals 4 and 5 (DRIVE). The important thing is that when the polarization motor is jogged CCW, the position count **MUST INCREASE**. If this is not the case, the wires attached to the connector J4 terminals labeled 3 (REF) and 1 (RTN) must be reversed. Note that the shield must always be connected to the RTN terminal.

To check the polarity of the polarization motor, the rotating feed limits must be set so that unrestricted movement of the feed is possible. To achieve this, the Rotating Feed CW Limit CONFIG mode item must be set to 0, and the Rotating Feed CCW Limit CONFIG mode item must be set to 1023.

The polarization motor may be jogged in MANUAL mode. Jog the pol motor and make sure that movement is in the proper direction - position count increasing for CCW movement. Note that once the rotating feed limits have been configured as described above, there are no limits on polarization movement. The user must be careful to not move the motor past a limit. Damage to the rotating feed, polarization motor, or potentiometer may occur if the limits are exceeded. If the user attempts to jog the polarization motor and no movement is detected on the position sense lines, or movement is detected in the wrong direction, the ANTENNA POL alarm will activate. If a polarization alarm is

active, an error message will flash on the bottom row of the display, and the polarization drive will be disabled. The alarm can be de-activated via RESET mode.

4. Once the polarity of the motor drive and sense lines have been verified, the pol limits may be set. To set the limits, the pol motor is jogged to the positions where it is desired to set a limit. This is done from MANUAL mode (with the Rotating Feed CW Limit and CCW Limit CONFIG mode items set as described above). It is recommended that an assistant be stationed at the antenna to ensure that the polarization motor's (or sensor's) mechanical limits are not exceeded. Record the count shown on the display at each of these positions for CW and CCW limit. Return to CONFIG mode, and enter these new limits for Rotating Feed CW Limit (the lower value) and Rotating Feed CCW limit (the greater value).

## 3.4 Setting Azimuth and Elevation Limits

The next step in the installation procedure is to ensure that the polarity of the motor drive wiring is correct, the position sensors and Polarotor<sup>™</sup> function properly, and then to set the azimuth and elevation limits. If there is an optional 24V-polarization drive installed, the Polarotor<sup>™</sup> function does not need to be checked. If the Polarotor<sup>™</sup> does not function properly (or if there is no polarization control of any type in the system), make sure that the Rotating Feed Present CONFIG mode item is set to 0. Note that not all versions of the software support polarization control. If the controller being installed does not support polarization control ignore the references to polarization control.

All of the operations outlined in this section can be carried out with the controller in LIMITS mode. **In LIMITS mode the user has unrestricted movement of the antenna, there are no software azimuth or elevation limits, and antenna jammed sensing does not take place. When moving the antenna in LIMITS mode an assistant should be stationed at the antenna to insure that the antenna does not move past a physical limit. Note also that the CW and CCW polarization adjustment keys are active.**

### 3.4.1 Motor Drive Polarity

The polarity of the azimuth motor drive is checked by depressing the AZ CCW key and verifying that the antenna moves in the proper direction. The sense of azimuth movement is as seen by an observer located above the antenna. In the northern hemisphere depressing the AZ CCW key should result in east movement. If the antenna does not move in the proper direction, connector J2 pins 4 and 6 need to be reversed. The polarity of the elevation motor drive is checked in a similar fashion.

The azimuth and elevation position sensor operation can be checked by jogging the antenna about the appropriate axis and verifying that the position count changes for that axis. Note that the position count will always decrease for AZ CCW and EL DOWN movement, and will always increase for AZ CW and EL UP movement. Also the count will not decrement lower than 1 or increment higher than 65535.

Polarotor operation is checked by using the POL CW and POL CCW keys to skew the polarization (on those controllers that support polarization movement).

### 3.4.2 Setting Limits

The azimuth counter-clockwise and/or elevation down limits are set first. The bottom row of the display prompts the user to set the limits for each axis. To set a limit, position the antenna using the Az/El jog keys at the desired limit, and hit either the 7 key to set an azimuth limit or the 9 key to set an elevation limit. When the azimuth counter-clockwise limit or elevation down limit is set, the position count for the axis is reset to 30. The limits should be specified so that there is adequate clearance between the antenna and any obstacles when the antenna is positioned at any azimuth/elevation combination within the limits.

## 3.5 Slow Speed Adjustment

The Adapti-Drive slow speed control system allows the user to specify a desired slow speed. When the antenna is moving at slow speed the controller will vary the voltage to the drive to maintain the actual antenna slow speed at the value specified by the user. Other slow speed drive systems in use reduce the voltage to the drive to a constant value whenever slow speed movements occur. This results in poor speed regulation as the load on the motor varies or as friction in the drive system changes with temperature.

For the RC2000C the user sets the slow speed for each axis independently by entering a slow speed code via the appropriate CONFIG mode prompt. This section outlines the procedure for selecting the appropriate slow speed code. When the system memory is reset the azimuth and elevation slow speed codes are initialized to 254 (maximum). If the speed code for a given axis is set to 254, the slow speed system for that axis is disabled, and full voltage is applied to the axis whenever slow speed is selected. If the speed code is set to 254 and slow speed is selected, the slow banner and a voltage code will be displayed, but the drive will move at fast speed and the voltage code will not change.

When slow speed movement occurs, the RC2000C determines the speed at which the actuator is moving by measuring the rate at which position feedback pulses are received for the axis which is being moved. The controller adjusts the voltage to the drive by using a Pulse Width Modulation (PWM) scheme, which essentially turns the 36-volt drive voltage off and on very rapidly. Whenever the antenna is manually jogged at slow speed (in MANUAL or SETUP mode) an indication of the voltage delivered to the drive is displayed to the right of the 'SLOW' banner. This quantity, referred to as a 'voltage code', varies from 1 to 24. The drive voltage associated with a voltage code of 1 is the minimum voltage that can be delivered to the actuators. A voltage code of 24 is associated with the maximum voltage that can be delivered to the drive.

To determine the slow speed code that is appropriate for the azimuth axis, use the following procedure. For 36-volt DC linear actuators, slow speed codes of 140 to 180 are common.

1. In MANUAL mode jog the antenna in azimuth at FAST speed for exactly 10 seconds and record the number of counts that occur. Make sure that the antenna does not reach a limit during the move.
1. Use the following table to determine an initial setting for the speed code.

<u>counts</u>	<u>speed code</u>	<u>counts</u>	<u>speed code</u>
60	80	300	165
70	90	350	170
80	100	415	175
95	110	525	180
120	120	715	185
145	130	1100	190
170	140	1325	195
200	150	1450	200
250	160		

3. Go to CONFIG mode and use the SCROLL keys to bring up the Azim Slow Speed item. Key in the new speed code followed by the ENTER key.
4. Go to MANUAL mode, toggle the speed to SLOW, and jog the antenna in azimuth. Continue jogging the antenna until the voltage code displayed to the right of the SLOW banner settles to a steady state range of values. This may take 5 to 10 seconds. If a limit is reached, jog the antenna in the opposite direction. After the voltage code settles to a steady state range of values, check the rate of movement to make sure that it is slow enough to be useful but not so slow that the motor stalls or moves in a jerky fashion. If the movement is not satisfactory increase or decrease the speed code by 3 to 5 counts. Increasing the speed code results in a faster rate of slow speed movement. Repeat steps 3 and 4 until satisfactory slow speed movement is attained.

A similar procedure is used to adjust the elevation slow speed.

## 3.6 Programming Geostationary Satellites

After the limits have been set and the slow speed code determined, geostationary satellites can be programmed into the controller's memory. Inclined orbit satellites are programmed into memory after the geostationary satellites are programmed (described in Chapter 4). The user should review this section along with the following section before programming in any satellites. The following section discusses the display of azimuth and elevation position data in an angle format, and explains the use of the IBM PC programs found on the disk included with the controller. Displaying the azimuth and elevation position in an angle format can be a great aid in locating satellites. Note that it is not necessary to program any geostationary satellites into memory before initiating a track on an inclined orbit satellite.

All satellites are programmed into memory via SETUP mode. In SETUP mode the user can jog the antenna in azimuth and elevation to peak up on a satellite, specify the satellite name, and jog the polarization to assign H and V polarization values (on those controllers which support polarization control). This information is retained in the controller's non-volatile memory. The user can automatically position the antenna on a satellite which has previously been programmed into memory by invoking the AUTO mode, and using the SCROLL keys followed by the ENTER key to select the satellite.

SETUP mode is straightforward. If the user wishes to assign a satellite name that is not in the list, the USER entry in the satellite name list may be selected. The user is then prompted to enter an alphanumeric string using the SCROLL UP, SCROLL DOWN, and ENTER keys.

After the satellite name has been selected the user is prompted to enter in the satellite's longitude position. If the satellite name came from the controller's internal list, the user is presented with a longitude value also from the controller's internal list. The range of longitude values accepted by the controller ranges from 0 to 180 West and 0 to 180 East. Satellites located over North America have West longitude values. Satellites located over Asia have East longitude values. Some Intelsat literature gives satellite longitude values in a range of 0 to 359. In this scheme, values from 0 to 180 correspond to East longitudes. Values from 180 to 359 correspond to West longitudes. To convert from the Intelsat scheme to the scheme used by the controller, a simple example is presented. If the satellite longitude is specified as 325 degrees in the Intelsat scheme, to convert to the value needed for entry into the controller, calculate  $360 - 325 (= 35)$ . The value entered into the controller would then be 35.0 West.

It is recommended that the user first program in a pair of geostationary satellites, and then use the AUTO mode to repeatedly position the antenna on one satellite and then the other. This will exercise the controller, actuators, mount, and position sensors. If the antenna does not return to the peak for each satellite make sure that the position sensors are properly wired. After the operation of the system has been verified by testing with two geostationary satellites, the rest of the satellites may be programmed in.

### 3.7 Angle Display of Az/EI Position Data

The RC2000C antenna controller has the capability to display its azimuth and elevation position in an angle format. This capability can facilitate the process of locating satellites during system setup. This section describes the procedure for enabling, calibrating, and using the angle display feature. The procedure outlined in this section makes use of the programs (designed to run on an IBM compatible PC) found on the floppy disk in the back of this manual.

The controller can display azimuth and elevation position in a degrees format. When this feature is enabled, the azimuth position is displayed as a true heading (in degrees - 0 to 360) and the elevation position is displayed as an angle above the horizon (0 to 90 degrees). This feature is controlled by parameters specified by the user via CONFIG mode. The scale3.exe program on the floppy disk can be used to determine these parameters once a pair of geostationary satellites has been found.

Another program included on the floppy disk is antenna.exe. This is a general purpose program that aids the user in locating any satellite. This program prompts the user to enter the antenna longitude and latitude, the satellite longitude and the satellite inclination angle and calculates the magnetic heading, true heading and elevation angle above the horizon needed to intercept the satellite. For geostationary satellites, the satellite inclination angle is 0.

The following step by step procedure can be used to locate geo-stationary satellites. In the process, the parameters needed to display azimuth and elevation parameters in an angle format will also be determined.

1. Determine the antenna latitude and longitude. Obtain a satellite guide and identify the pair of satellites that will be located initially and used to calibrate the angle display. A reasonable selection would be a pair of satellites with many readily identifiable active transponders that are located 10 to 15 degrees apart (in longitude) placed somewhere in the middle of the arc.
2. Invoke the antenna.exe program to determine the magnetic heading and elevation angle needed to intercept each satellite. If the elevation angles calculated for the two satellites are within 4 degrees, select another satellite. To run the antenna.exe program, simply type ANTENNA followed by the enter key at the DOS prompt. Position the antenna on each satellite. A magnetic compass and an inclinometer can be used to help point the antenna in the proper direction. For each satellite, record the longitude and the antenna azimuth and elevation count values where the satellite was located.

3. After the two satellites have been found, invoke the scale3.exe program on the floppy disk in the back of this manual to calculate the Display Az Gain, Display Az Offset, Display EI Gain, and Display EI Offset parameters which will be entered into the controller via CONFIG mode.
4. In this step the values obtained in step 3 are entered into the controller's memory via CONFIG mode. Activate CONFIG mode, and enable Expert Access (section 2.5). At the Angle Display Enable CONFIG mode item, enter a 1 to enable angle display. Next, enter the values obtained in step 3 for Display Az Gain, Display Az Offset, Display EI Gain, and Display EI Offset. Values must also be entered for the Antenna Latitude and Antenna Longitude CONFIG mode items. A latitude or longitude entry is performed in two parts. The numerical value is entered first (followed by the ENTER key). Next the direction is specified, either E (East) or W (West) for longitude or N (North) or S (South) for latitude (followed by the ENTER key).

Be sure to terminate all CONFIG mode numeric entries with the ENTER key. When all of the parameters have been entered, scroll back through the list to make sure that each entry is correct.

5. To locate additional satellites, invoke the antenna.exe program to determine the true heading and the elevation angle required to intercept the satellite. Note that when the controller's angle display feature is enabled, the azimuth position is displayed as a true heading. Simply jog the controller until the displayed azimuth position matches the true heading value predicted by the antenna.exe program and the displayed elevation position matches the elevation value predicted by the program. Jog the antenna in azimuth about the predicted position to find the satellite

For mounts that employ linear actuators, there will be an error in the controller's displayed values for true heading and elevation. The error will be negligible when the antenna is located near the satellites used to calibrate the angle display (the satellites found in step 2). The error will be greater as the antenna is moved away from those satellites. This occurs because the controller uses a linear mapping of position counts to display angle. For a mount which uses a linear actuator, the actuator forms one side of a triangle and as that side gets shorter or longer, the opposite angle changes. For this case the mapping of position counts to antenna pointing angle is described by trigonometry and will be non-linear. To minimize the error, try to choose a pair of satellites in the middle of the arc to perform the calibration.

## 3.8 AutoPol

This section covers the installation and software configuration required to use the AutoPol feature. The AutoPol function allows the antenna polarization to be controlled via a digital input to the controller. When enabled, AutoPol is active whenever the controller is in MANUAL or TRACK mode. Note that the H, V, POL CW and POL CCW keys do not work when AutoPol is enabled. The AutoPol input of the RC2000C is driven by a digital output from a satellite receiver. The AutoPol input responds to a digital level, with a high level being one polarity and a low level the other polarity. The mapping of a high level on the digital input to either H or V polarization is referred to as the AutoPol polarity, and is controlled via a CONFIG mode item.

The AutoPol input on the controller has an internal pull-up resistor which means that the input will float high when it is not driven by the receiver. This allows the receiver to use a relay contact closure to drive the AutoPol input. One side of the relay can be connected to ground and the other side connected to the AutoPol input. When the relay is active the AutoPol input is connected to ground - a low level input, and when the relay is open the AutoPol input floats high due to the pull-up in the RC2000C.

Here is the procedure for installing and configuring the AutoPol feature:

1. Identify an output on the receiver that can be used to drive the AutoPol input on the RC2000C. Note if a high level output corresponds to V polarization or H polarization.
2. Connect the AutoPol input as shown in figures 3.2 or 3.3.
3. Go to CONFIG mode, use the SCROLL keys to bring up the AutoPol Enable prompt, and key in 1 followed by the ENTER key.
4. Use the SCROLL keys to bring up the AutoPol Vpol Level item. If a high level corresponds to vertical polarization, key in 1 followed by the ENTER key. If a high level corresponds to horizontal polarization, key in 0 followed by the ENTER key.

5. Go to MANUAL mode and verify that the AutoPol feature works properly. In MANUAL mode, when the AutoPol feature is active the polarization display banner reads 'AP:' rather than 'PL:'.

### 3.9 Simultaneous Azimuth and Elevation Movement

The RC2000C has the capability to move the azimuth and elevation axis actuators simultaneously during AUTO mode moves. The use of this feature is subject to a limitation in that the total current draw for both 36-volt actuators combined cannot exceed 8 amps. If this requirement is satisfied over all operating conditions, simultaneous azimuth and elevation movement can be enabled by going to the CONFIG mode Simultaneous Az/EI Enable item and keying in 1, followed by the ENTER key.

### 3.10 Installation and Setup Checklist

This section gives a summary of the installation and configuration procedure outlined in this chapter. The summary is presented in the form of a checklist.

1. Before power is applied verify that the line voltage is correct. Check the sticker over the power entry module.
2. Make sure that the memory has been cleared. The controller should come up in LIMITS mode.
3. Make the required electrical connections. Shielded cable must be used for the position sensors and the shields must be connected at the back of the controller and NOT at the antenna. Refer to figures 3.1, 3.2, and 3.3.
4. If the RC2KPOL option (which allows the RC2000C to interface to a 24 volt DC polarization control motor) is installed, make the required electrical connections for the motor and sensor, verify the polarity of the motor and the position feedback sensor, and set the polarization limits. Make sure that when the CCW key is depressed to jog the polarization motor counter-clockwise, the displayed position count INCREASES. Use caution to avoid damaging the potentiometer.
5. Go to LIMITS mode and verify the motor drive polarity. Set the azimuth CCW, azimuth CW, elevation down, and elevation up limits.
6. Enter the Azim Slow Speed and Elev Slow Speed CONFIG mode items. See section 3.5 for setting the slow speed. For a standard 36 volt DC linear actuator with 30 to 40 pulses per inch, a slow speed value code of 140 to 180 is generally appropriate.
7. Go to SETUP mode and program in the geostationary satellites. Review section 3.7 which describes a procedure for locating satellites that makes use of the RC2000's ability to display azimuth and elevation position in an angle format.
8. If desired, enable the AutoPol feature to slave the controller's polarization control output to a satellite receiver. A digital output on the receiver must be connected to the AutoPol input of the controller, and the AutoPol feature must be enabled via CONFIG mode.
9. Enable simultaneous azimuth and elevation movement in AUTO mode if the total combined current draw from both actuators is less than 8 amps over all operating conditions.

## Chapter 4 INCLINED ORBIT SATELLITES

This chapter describes the characteristics of inclined orbit satellites and the tracking algorithms available on the RC2000C. The chapter begins with a tutorial on inclined orbit satellite operation, and continues with a description of the controller's tracking algorithms. It concludes with a section that guides the user through the hardware and software configuration procedure which must be performed prior to initiating a track on an inclined orbit satellite.

### 4.1 Geostationary and Inclined Orbit Satellites

To successfully track inclined orbit satellites with the RC2000C it is necessary to become somewhat familiar with the characteristics of an inclined orbit satellite's apparent motion as seen by the antenna. This section briefly reviews the orbital geometry of geostationary satellites, and then discusses inclined orbit satellites.

A geostationary satellite appears fixed in space to an observer at any point on the earth. In reality, the earth is rotating about its axis, and the satellite appears to be stationary because it is orbiting the earth in the earth's equatorial plane with a period identical to the earth's rate of rotation. The earth's equatorial plane is the plane defined by the earth's equator. Please refer to figure 4.1.

Many forces act on a satellite in geostationary orbit that tend to tilt the satellite's orbital plane away from the earth's equatorial plane and to pull the satellite out of its assigned longitudinal position. These forces are due to the gravitational attraction of the moon (which also gives rise to ocean tides) and the nonspherical earth. A discussion of these forces is beyond the scope of this presentation. A geostationary satellite must expend propellant to perform station-keeping maneuvers to maintain an orbit at the proper longitudinal position within the earth's equatorial plane.

East-West station-keeping maneuvers are performed to maintain the satellite's longitudinal position and North-South station-keeping maneuvers are performed to keep the satellite's orbital plane aligned with the earth's equatorial plane. Between 20 and 40 percent of the satellite's launch weight is due to station-keeping propellant. A satellite's design life is determined by the amount of station-keeping fuel onboard. A satellite is sometimes allowed to drift into an inclined orbit to extend its operational life. For a geostationary satellite, approximately 90 percent of the propellant is expended for North-South station-keeping activities. If North-South station-keeping ceases the operational life of the satellite may be greatly extended.

The orbital plane of an inclined orbit satellite is 'inclined' with respect to the earth's equatorial plane. Note that in figure 4.1 the inclination angle between the inclined orbit satellite's orbital plane and the earth's equatorial plane is greatly exaggerated. Typical inclination angles are less than 10 degrees. When satellite North-South station-keeping activities are suspended, the inclination of the satellite's orbit increases by approximately 0.9 degrees per year. Whereas a geostationary satellite appears fixed in space, the apparent position of a satellite in an inclined orbit varies with time.

If an inclined orbit satellite could be viewed by an observer located at the center of the earth, the apparent motion of the inclined orbit satellite would be a figure eight centered on the earth's equatorial plane. The motion of the satellite is periodic, which means that the figure eight pattern repeats itself. The period of the motion is 23 hours, 56 minutes, and 4 seconds. To an observer located at the center of the earth, the angle subtended by the figure eight pattern from North to South (i.e. height of the figure '8') is twice the inclination angle and the angle subtended by the figure eight pattern from East to West (i.e. width of the figure '8') is approximately the inclination angle (in degrees) squared divided by 115.

The apparent motion is slightly greater and somewhat skewed when viewed from the surface of the earth. The exact shape of the pattern varies with the longitudinal position of the satellite and the place on the earth from which the satellite motion is viewed. To estimate the height and width of an inclined orbit satellite's motion as viewed from the surface of the earth, a good approximation is to multiply the results of the equations above by 1.2.

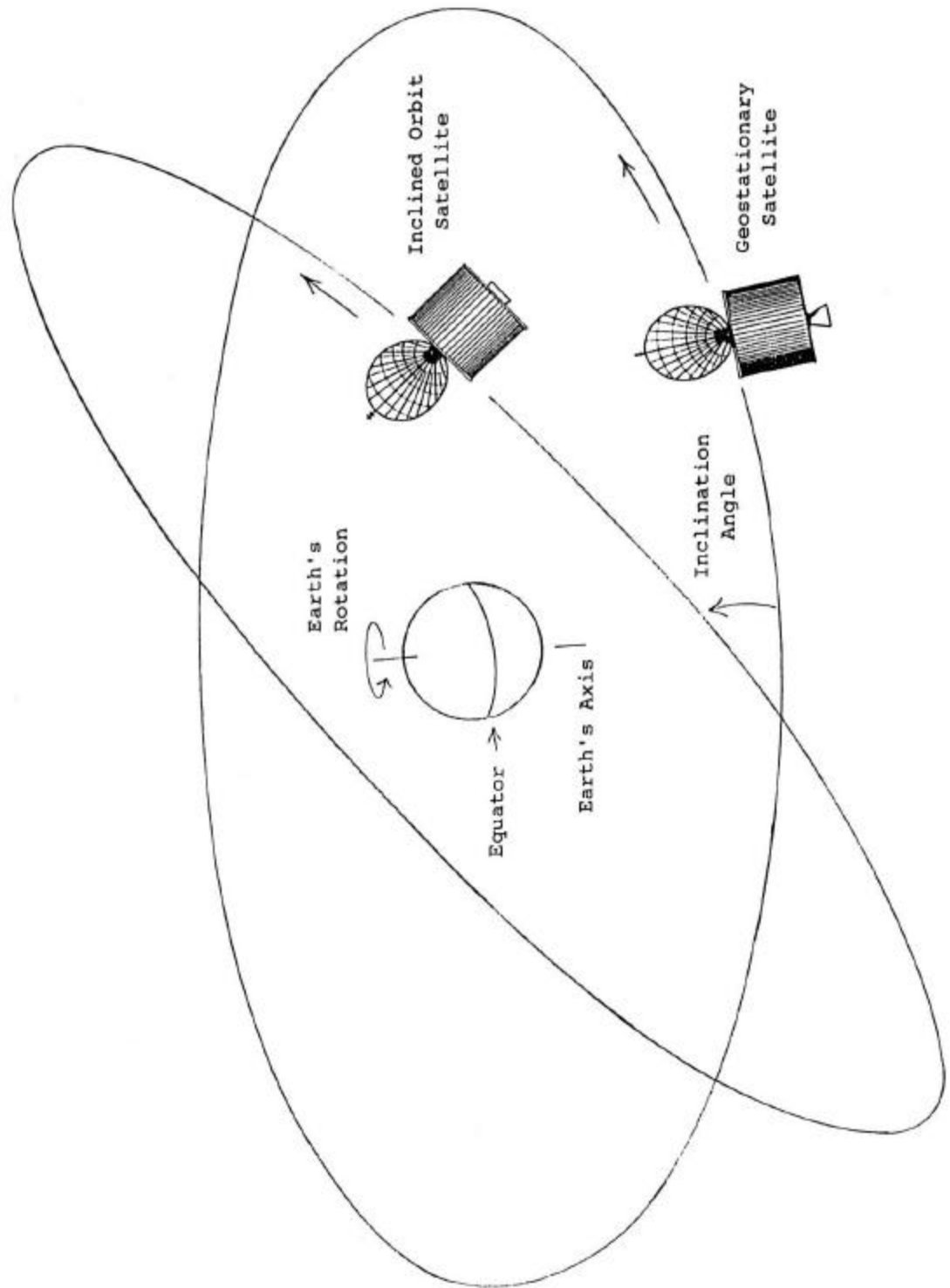

**Figure 4.1 - Earth's Equatorial Plane**

Examination of these relationships show that the figure eight pattern is much taller than it is wide. For example, if the orbital plane of a satellite is inclined with respect to the earth's equatorial plane by 5 degrees, the apparent height and width of the figure eight pattern of the satellite's apparent motion as viewed from the surface of the earth is:

Height (North to South):  $1.2 * 2 * 5 = 12$  degrees

Width (East to West):  $(1.2 * 5 * 5) / 115 = 0.26$  degrees

This example shows that the apparent motion of the satellite is practically a straight line. This knowledge of the satellite's apparent motion as viewed by the antenna is exploited by the RC2000C tracking antenna controller.

The 23 hour, 56 minute, and 4 second period of the satellite's apparent motion is referred to as a sidereal day. A sidereal day is the time that it takes the earth to complete exactly one revolution. The '24 hour' solar day is the period of time that it takes the sun to reach the same point in the sky. The solar day is longer than the sidereal day because the earth is in orbit around the sun and the earth must rotate more than 360 degrees for the sun to reach the same point in the sky.

Sidereal time refers to the time reference used to record time during a sidereal day. A sidereal time clock would progress up to 23 hours, 56 minutes, 3 seconds and then wrap around to 0 hours, 0 minutes, 0 seconds. All sidereal times used by the RC2000C controller and referenced in this manual are in seconds.

The apparent motion of the satellite as seen by the antenna is at it greatest when the satellite is passing through the earth's equatorial plane. The apparent motion of the satellite is zero at the endpoints of the figure eight pattern when the satellite appears to reverse direction.

## 4.2 RC2000C Tracking Algorithm

The tracking algorithm used on the RC2000C can be divided into 3 distinct parts, or submodes - STEP\_TRACK, PROGRAM\_TRACK, and SEARCH. A TRACK\_ERROR submode is also implemented. These submodes are summarized here to provide an overview of the tracking algorithm. The following sections will provide much greater detail. Notice that certain words are italicized in the following subsections. The italicized text refers to parameters which are specified by the user either at the time of system installation (via CONFIG mode), when a track is initiated (via SETUP mode), or once a track has been established (via the TRACK mode menu). The idea is to get the user familiar with the parameters that he or she must either specify or adjust. All of these parameters are described in more detail in later sections.

The TRACK submodes will be described in chronological order as seen by a user initiating a track on an inclined orbit satellite. A track is initiated from SETUP mode. The user peaks the antenna on the inclined orbit satellite, selects the satellite name, *longitude*, *inclination* and frequency *band*, and then sets the satellite's horizontal and vertical polarization positions. At this point the controller enters STEP\_TRACK mode. Note that not all versions of the software support polarization control.

In the STEP\_TRACK submode the controller periodically performs peakups on the inclined orbit satellite. It stores azimuth and elevation positions of these peaks in a track table in non-volatile memory. The track table divides the sidereal day into 48 time segments. Whenever the current sidereal time equals the starting time for one of the 48 time segments, a peakup occurs and the antenna azimuth and elevation values are stored into the appropriate position within the track table. The track table stores a map of the satellite's apparent motion as seen by the antenna.

During a step\_track operation, the controller peaks the antenna by monitoring the received signal strength. Signal strength information is available to the controller via the AGC (automatic gain control) input. The AGC input accepts a DC signal generated by the AGC circuits of a satellite receiver, or by a beacon receiver. The AGC setup and configuration procedure is described in section 4.4.1.

The PROGRAM\_TRACK submode is active whenever a satellite's track table contains valid satellite position data for the current time. When PROGRAM\_TRACK is active the antenna smoothly tracks the satellite by interpolating between track table azimuth and elevation position entries. Once a complete track table has been established for a satellite, the controller will remain in the PROGRAM\_TRACK submode.

The SEARCH submode is active when the satellite signal is lost and track table data is not available. In this submode the controller performs a search for the satellite in the region where it calculates the satellite will be found, based on its knowledge of the satellite's apparent motion. If the satellite is found while the controller is performing a search, the STEP\_TRACK submode will receive control. If the satellite is not found while performing the search, the controller will wait *Search Retry Interval* minutes and perform another search. If while waiting for the *Search Retry Interval* to expire, the sidereal time advances to a time for which valid track table data is available, the PROGRAM\_TRACK mode will become active.

The automatic search may be disabled via the *Search Enable* CONFIG mode item. If the automatic search is disabled, the user is simply prompted to position the antenna on the satellite and hit the ENTER key.

The TRACK\_ERROR submode becomes active whenever an error occurs. Some of the errors which can occur are: antenna jammed, antenna limit reached while tracking, antenna runaway, track table data corrupted, system CONFIG data corrupted, or a peak limit error has occurred (while peaking the antenna the controller had to move too far - possibly peaking on an adjacent satellite). Errors are described in Chapter 7.

#### 4.2.1 STEP\_TRACK

In the STEP\_TRACK submode, the controller will periodically jog the antenna in elevation and then azimuth to peak up the antenna's received signal strength. This step track operation will be referred to as a peakup. The STEP\_TRACK submode is active whenever there is no track table information available for the current sidereal time and a satellite signal is present.

When STEP\_TRACK mode is active, two events can trigger a step track operation. The first is when the current sidereal time reaches a value that corresponds to one of the 48 track table entries. The second is when the controller calculates that the antenna pointing error exceeds the value specified by the user. The *Max Track Error* CONFIG mode item allows the user to specify the maximum tracking error in tenths of a dB.

The controller constantly calculates the antenna pointing error based on the following data: the apparent motion of the satellite (determined by the *Inclination* of the satellite's orbital plane), the antenna's beamwidth (determined by the *Antenna Size* and the satellite frequency *Band*), and the length of time since the last peakup. To determine the peakup interval the controller assumes that the satellite is always moving at its maximum velocity as seen by the antenna. The maximum velocity occurs when the satellite is passing through the earth's equatorial plane. When the controller determines that in length of time since the last peakup occurred the satellite could have moved so far as to allow the antenna pointing error to exceed the *Max Track Error* specified by the user, a peakup will be initiated.

The size of the azimuth and elevation movements (or step sizes) for the step track operation is also determined by the *Max Track Error* value. The step size corresponds to the angular movement of the antenna that would change the received signal strength by *Max Track Error* tenths of a dB. It is calculated based on the antenna's beamwidth and radiation pattern.

Reducing the *Max Track Error* value results in more frequent step track operations with smaller step sizes. There are limits to how small the max track error may be. This is discussed in section 4.4.5 - Tracking Problems. Step track operations will occur more frequently for satellites with larger orbital *Inclination* values, or with larger antenna sizes. For a given *Antenna Size* and satellite *Inclination*, step track operations will occur more frequently for Ku band transponders than for C band transponders. (The user is prompted to enter satellite *Band* data during setup.) For hybrid satellites (both C and Ku band), the TRACK menu system allows the user to switch bands.

The STEP\_TRACK submode will pass control to these TRACK mode submodes on the following conditions:

PROGRAM\_TRACK..receives control when the current sidereal time equals a time for which track table data is available.

SEARCH..receives control if the satellite signal is lost.

ERROR..receives control if any error is encountered.

## 4.2.2 PROGRAM\_TRACK

When the PROGRAM\_TRACK submode is active, the controller smoothly positions the antenna to azimuth and elevation positions derived from the track table, regardless of whether a satellite signal is present or not. The track table holds a map of the satellite's apparent motion as a function of sidereal time. The controller performs a linear interpolation between adjacent track table entries to determine the correct antenna position.

In PROGRAM\_TRACK submode antenna movement occurs whenever the controller calculates that the error between the antenna's current position and the antenna's proper position as determined from the track table exceeds *Max Track Error* tenths of a dB. To determine the error between the current and calculated antenna position, the controller calculates the antenna beamwidth based on the *Antenna Size* and the frequency *Band*. If the *Max Track Error* parameter is decreased in value, the antenna pointing error will be less, but the antenna will move more often, which increases wear on the antenna actuators.

The PROGRAM\_TRACK submode also periodically performs peakups (similar to STEP\_TRACK submode) to check the accuracy of track table entries. If the discrepancy between the peakup position and the position stored in the track table is greater than that specified by the *Max Track Error* parameter, the update flag for each entry in the track table is set TRUE. The frequency at which these track table accuracy checks occur is determined by the *Update Check* parameter. The default *Update Check* interval is 33 hours, but can be changed by the user to any value in the range of 1 to 999 hours (via the TRACK MENU system).

If the current sidereal time reaches a value that corresponds to an entry in the track table whose update flag is set TRUE, and the current signal strength level indicates that a satellite signal is present, a peakup will occur, the track table entry will be updated, and the track table update flag is reset FALSE. If the satellite signal is not present the update flag remains set TRUE and the system will try again in 23 hours, 56 minutes, and 4 seconds. The user can view the contents of each track table entry and examine the present state of the update flag. In addition the user can invoke the Force Update or Reset Update functions to force the update flag for each entry in the track table to be either set TRUE or reset FALSE, respectively. These functions are accessible via the TRACK MENU system, which is described in more detail in section 5.4.5.

The PROGRAM\_TRACK submode will pass control to the other TRACK mode submodes under the following circumstances:

STEP\_TRACK..receives control when the current sidereal time reaches a value for which there are no valid track table entries and a valid satellite signal is present.

SEARCH..receives control when the current sidereal time reaches a value for which there are no valid track table entries and a valid satellite signal is not present.

ERROR..receives control when any error is encountered.

## 4.2.3 Intelli-Search

The SEARCH submode receives control whenever the satellite signal is lost and the track table does not contain antenna azimuth and elevation position data for the current sidereal time. Whenever the SEARCH submode is active the controller periodically performs a search over the region where the controller has calculated that the satellite will be found. The Intelli-Search algorithm determines the extent of the search region based on the *Satellite Longitude*, the *Antenna Latitude* and *Antenna Longitude*, the antenna beamwidth (as calculated from the *Antenna Size* and frequency *Band*), and the *Elev Constant* and *Azimuth Constant* Scale Factors.

The *Azimuth Constant* and *Elev Constant* scale factors refer to the mapping of antenna azimuth and elevation position counts to antenna azimuth and elevation angles, respectively. The elevation scale factor is entered by the user. The azimuth scale factor can either be specified by the user, or it can be derived from the position and *Longitude* data of adjacent geostationary satellites. Scale factors are discussed in more detail in the next section.

The use of the Intelli-Search algorithm relieves the user of the task of having to specify the controller's search region. Other tracking antenna controllers limit the search to a box shaped region and force the user to determine the boundaries of the search region, which is often a trial and error process. Please

refer to figure 4.2. If the box shaped region specified by the user is too small the controller may not search the entire region where the satellite's apparent motion takes it, and for some segments of the satellite's movement, the controller may not be able to find the satellite. If the box search region is too large, the controller may find an adjacent satellite. If the search region is not centered properly, both of the error conditions described above could occur.

The Intelli-Search algorithm calculates the shape of the search region based on easily determined physical data supplied by the user, and information derived from the antenna positions and longitudes of the geostationary satellites in the vicinity of the inclined orbit satellite which is being tracked. In most cases the search region is shaped like a parallelogram. The long dimension of the parallelogram is calculated based on the satellite *Inclination* angle specified by the user when the track is initiated from SETUP mode. The width (or short dimension) of the parallelogram is specified by the *Search Width* parameter entered via CONFIG mode. The *Search Width* has a range of values of 1 to 10, with 1 specifying the narrowest search window and 10 specifying the widest window. The default value of 3 is adequate for most situations.

If a satellite signal is found during a search, the controller switches to the STEP\_TRACK submode. If a satellite signal is not found during the search, the unit waits awhile and then performs another search. If during the wait the sidereal time advances to a value for which there is valid track table data, the controller will switch to the PROGRAM\_TRACK mode. The wait period between successive searches is determined by the value of the *Search Retry Interval* parameter. The default value of this parameter is 10 minutes, but it can be changed to any value between 0 and 999 minutes via the TRACK menu.

The search consists of successive sweeps separated from one another by an angle corresponding to a 2-dB rolloff of the antenna pattern. The antenna pattern is calculated based on the Antenna Size and frequency Band. The controller will usually sweep in azimuth, increment the elevation angle, and then sweep again in azimuth. This will continue until the entire search region has been covered. The automatic search may be enabled or disabled via the Search Enable CONFIG mode item. When the automatic search is disabled, the user is prompted to manually jog the antenna onto the desired satellite, and then hit the ENTER key.

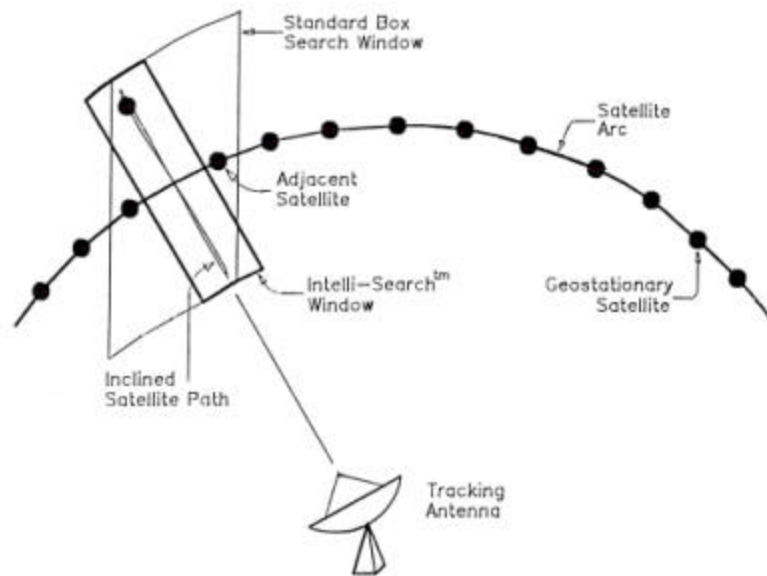

**Figure 4.2 – Intelli-Search**

### 4.3 Implementing the Tracking Algorithms

This section describes the information needed to implement the tracking algorithms. The purpose of this section is to give the user insights into the operation of the controller and to prepare for the actual entry of the setup information in the following sections.

### 4.3.1 Location Information

The *Antenna Latitude*, *Antenna Longitude*, and the *Longitude* of the inclined orbit satellite to be tracked must be specified in order to determine the satellite's apparent motion. In most cases the satellite's apparent motion as seen by the antenna mount is a skewed figure eight shape. This information is needed to implement the controller's Intelli-Search algorithm.

### 4.3.2 Antenna Scale Factors

The azimuth and elevation scale factors refer to the mapping of antenna azimuth and elevation position counts to antenna azimuth and elevation angles. The elevation scale factor is entered by the user. The azimuth scale factor can either be specified by the user, or it can be derived from the position and longitude data of adjacent geostationary satellites.

Scale factor information is entered into the controller via the *Azim Constant* and *Elev Constant* CONFIG mode items. A non-zero value for the *Elev Constant* must be entered into the controller. If the *Azim Constant* CONFIG mode item is initialized to a non-zero value, that value is used as the azimuth scale factor. If the *Azim Constant* is initialized to a value of zero, the controller calculates the azimuth scale factor based on the position and longitude data of geostationary satellites in the vicinity of the inclined orbit satellite.

If the *Azim Constant* has a value of zero at least two geostationary satellites must be programmed into memory (via SETUP mode) before a track may be initiated on an inclined orbit satellite. For this case it is also very important that the proper longitude values be specified for geostationary satellites which are programmed into the controller's memory. If a geostationary satellite is programmed into memory with an incorrect longitude value (angle or direction), the controller will accurately position the antenna on the geostationary satellite when it is recalled via AUTO mode, but may not track an inclined orbit satellite properly which is located in the vicinity of the geostationary satellite. **Verify the longitude value of all satellites programmed into the controller via setup mode if the controller is using geostationary satellites to determine the azimuth scale factor.**

### 4.3.3 Antenna Radiation Pattern

The antenna radiation pattern specifies antenna receive power versus antenna pointing angle relative to boresight. Boresight is the pointing angle associated with maximum received power from a given satellite. The controller calculates the shape of the antenna's radiation pattern by knowing the *Antenna Size* and the frequency *Band* (L, C or Ku) currently in use. *Antenna Size* data is entered via a CONFIG mode prompt. The frequency *Band* data is specified in SETUP mode when the user initiates a track on an inclined orbit satellite. Note that the controller also allows the user to specify a dual band inclined orbit satellite. For this case the user is prompted to supply frequency band data on entry into TRACK mode, and is allowed to change the *Frequency Band* via the TRACK mode menu.

Antenna radiation pattern information is necessary to allow the user to specify a maximum allowable antenna pointing error (*Max Track Error*) in tenths of decibels (dB) rather than in elevation and azimuth position counts. The *Maximum Track Error* is used to determine the step size and the frequency of antenna movement in the STEP TRACK and PROGRAM TRACK sub-modes. In addition, antenna radiation pattern information is used in SEARCH mode to determine the width of the parallelogram-shaped search region, and the angle between successive sweeps.

### 4.3.4 Real Time Clock

The controller contains a real time clock (powered by the same lithium battery that powers the controller's non-volatile memory) which is used to calculate the sidereal time. The period of the satellite's motion is one sidereal day. The controller maintains a track table that contains the satellite's azimuth and elevation positions as a function of sidereal time. The controller uses the time and date maintained by the real time clock to calculate the sidereal time. The user specifies the *Time* and *Date* via CONFIG mode prompts.

It is important that the user not change the time value when the time changes from Standard Time to Daylight Savings Time. The satellite does not experience the time shift. If the time is changed forward or backward by one hour, the data in the program track table will no longer be correct. For this reason the user should not change the time as the time standard changes. If this causes confusion the time may be specified as Universal Coordinated Time (formerly known as Greenwich Mean Time - GMT). Note that the real time clock used in the controller will properly account for leap years.

### 4.3.5 Receiver AGC Signal

To implement the tracking algorithms, the controller requires an input signal that indicates the strength of the received signal. Such a signal is generated within a satellite receiver, and is referred to as an AGC signal. (AGC is the abbreviation for Automatic Gain Control.) On satellite receivers, this signal may also be referred to as a 'Signal Strength' or 'Tuning Meter' output. An AGC output typically varies in proportion to the received power of the transponder that the receiver is currently tuned to.

The signal strength input is used to peak up the antenna while step tracking. The step tracking operation positions the antenna so as to maximize the received signal strength. Signal strength is also used to determine whether or not a satellite transponder is currently active. If the signal strength reading falls below a threshold set by the user, the controller assumes that a satellite signal is not present. If the satellite signal is lost while step tracking, the SEARCH sub-mode receives control. When the PROGRAM\_TRACK sub-mode is active, the presence of a satellite signal governs whether or not track table update operations are performed. The procedures required to set up the controller for various receiver AGC configurations are covered in detail in the next section.

## 4.4 Configuring the Tracking System

This section describes the procedures that the user must follow to configure the tracking system. The procedures for adjusting the AGC gain and offset pots, determining the AGC threshold parameters, and entering other CONFIG mode data pertaining to the tracking system, are all covered in this section.

### 4.4.1 AGC Adjustment and Configuration

The use of the AGC signal was described in the previous section. The controller has the provision to process two channels of AGC information. This means that two receivers can be connected to the controller (at least one receiver is required). The two channels are referred to as AGC1 and AGC2. The controller uses the stronger of the two as its AGC input. Each channel has separate gain and offset potentiometer adjustments. The installer uses the pots to transform the receiver's AGC signal swing into a range of values which is easily measured by the controller.

In addition to the potentiometers, there are three CONFIG mode items that are related to the AGC system. The three items are ...

1. AGC Polarity Flag - This flag indicates to the controller whether a stronger satellite signal corresponds to a higher AGC voltage (positive polarity) or a lower AGC voltage (negative polarity). Both AGC channels must have the same polarity. Each AGC channel contains an internal pull down resistor. This means that if one of the AGC channels is unused, its input is pulled to ground. This can cause problems if the AGC Polarity Flag specifies negative polarity, because an input of zero volts (ground potential) corresponds to the strongest possible satellite signal. For this case the installer must place a jumper from connector J1, pin 11, to the unused AGC input channel and adjust that channel's potentiometers (after negative polarity has been specified) so that its signal strength value is 0. J1 - pin 11 has a potential of 5.7 volts.
2. AGC C Band Threshold - When the receiver is tuned to a C band satellite and the signal strength is above this value, it is assumed that a satellite signal is present. The same threshold is applied to both AGC channels.
3. AGC K/L Band Threshold - This is similar to the C Band Threshold described above, except it pertains to Ku or L Band. If the signal strength is above this value when the receiver is tuned to a Ku or L band satellite, the controller assumes that a satellite signal is present.

The signal strength is displayed when MANUAL, TRACK, SETUP, and LIMIT modes are active. In MANUAL, TRACK, and SETUP modes, the signal strength of the AGC channel that corresponds to the strongest received satellite signal is displayed. In LIMIT mode, the signal strength of both AGC channels is displayed (the first value corresponds to AGC1). The signal strength is displayed as a number in the range of 0 to 1023. Note that in MANUAL, TRACK, and SETUP modes, the maximum signal strength that can be displayed is 999. A signal greater than 999 is displayed as '\*\*\*\*'. The displayed value takes into account the setting of the AGC Polarity Flag. In other words, a greater signal strength value always corresponds to a stronger received satellite signal.

### Single Receiver - Single Frequency Band Inclined Orbit Satellite AGC Setup

The following paragraphs describe the setup procedure for the simplest case - only one receiver and controller AGC input are used, and the user is tracking only C band (or only Ku or L band) inclined orbit satellites.

1. Align the antenna with a strong satellite (geostationary or inclined orbit) of the proper frequency band. Place a voltmeter on the receiver's AGC output, measure and record the voltage. In the description that follows, the term 'on satellite' will be used to refer to the antenna aligned with a strong satellite.
2. Jog the antenna off of the satellite so the antenna is looking at nothing. Measure and record the receiver's AGC voltage. In the description that follows, the term 'off satellite' will be used to refer to this case where the antenna is positioned well off of any satellite, looking at nothing.
3. If the difference between the two recorded values is less than 1 volt, connect the receiver's AGC output to the controller's AGC1 input. Otherwise, connect the receiver's AGC output to the controller's AGC2 input. Be sure to connect the ground return of the controller to a ground on the receiver. See figure 3.1.
4. If the AGC voltage associated with the 'on satellite' case is greater than that of the 'off satellite' case, the receiver has POSITIVE AGC polarity (otherwise the receiver has NEGATIVE AGC polarity). Go to CONFIG mode and use the SCROLL keys to bring up the AGC Polarity Flag item. Key in the proper polarity using either the 0 or 1 key, and terminate the entry with the ENTER key.
- 5a. If the receiver's AGC has NEGATIVE polarity, go to step 5b. If the receiver's AGC has POSITIVE polarity, go to LIMITS mode and examine the signal strength for the AGC channel that was not selected in step 3. If the signal strength reading for that channel is greater than 10, adjust the OFFSET and GAIN for that channel until the signal strength reading for that channel is less than 10. To lower the displayed signal strength turn the OFFSET pot clockwise and the GAIN pot counter-clockwise. Be sure not to turn the controller off while the controller is in LIMITS mode, or else the limits that have previously been set will be corrupted. Proceed to step 6.
- 5b. If the receiver's AGC has NEGATIVE polarity, connect a jumper from the controller's unused AGC input channel to connector J1, pin 11. Go to LIMITS mode and examine the signal strength for the AGC channel that was not selected in step 3 above. If the signal strength reading for that channel is greater than 10, adjust the OFFSET and GAIN pots for that channel until the signal strength reading for that channel is less than 10. To lower the displayed signal strength value, turn the OFFSET pot counter-clockwise and the GAIN pot clockwise. When this is accomplished proceed to step 6.
6. In the next few steps of the procedure, the OFFSET and GAIN pots of the AGC channel connected to the receiver's AGC output are adjusted so that the 'off satellite' signal strength value is between 50 and 100 and the 'on satellite' signal strength value is between 600 and 700.

Note that the GAIN and OFFSET adjustments are implemented using 20 turn pots. A lot of turns may be required.

If the receiver has POSITIVE polarity proceed to step 7. If the receiver has NEGATIVE polarity proceed to step 8.

7. Go to MANUAL mode, position the antenna 'off satellite', and adjust the OFFSET pot (for POSITIVE polarity receivers) or the GAIN pot (for NEGATIVE polarity receivers) so that the signal strength reading is about 75.

If the AGC has POSITIVE polarity and the signal strength is too low, turn the OFFSET pot counter-clockwise. If the AGC has POSITIVE polarity and the signal strength is too high (or is '\*\*\*'), turn the OFFSET pot clockwise.

If the AGC has NEGATIVE polarity and the signal strength is too low, turn the GAIN pot counter-clockwise. If the AGC has NEGATIVE polarity and the signal strength is too high (or is '\*\*\*'), turn the GAIN pot clockwise.

8. While still in MANUAL mode, position the antenna 'on satellite' and adjust the GAIN pot (for POSITIVE polarity receivers) or the OFFSET pot (for NEGATIVE polarity receivers) so that the signal strength value is about 650.

If the AGC has POSITIVE polarity and the signal strength is too low, adjust the GAIN pot clockwise. If the AGC has POSITIVE polarity and the signal strength value is too high (or is '\*\*\*\*'), adjust the GAIN pot counter-clockwise.

If the AGC has NEGATIVE polarity and the signal strength is too low, adjust the OFFSET pot clockwise. If the AGC has NEGATIVE polarity and the signal strength value is too high (or is '\*\*\*\*'), adjust the OFFSET pot counter-clockwise.

9. Position the antenna 'off satellite'. If the signal strength is between 50 and 100, proceed to step 10. If the signal strength is less than 50 or greater than 100 perform steps 7 and 8 again.
10. Position the antenna 'on satellite'. Jog the antenna off of the satellite until the picture is just barely watchable. Note the signal strength value. Go to CONFIG mode and use the SCROLL keys to bring up either the AGC C Band Threshold item or the AGC K/L Band Threshold item, whichever is appropriate for the frequency band that the user has chosen to operate at (and has adjusted the pots at). Key in the signal strength value noted above. Terminate the entry with the ENTER key. Typical CONFIG mode threshold values are 150 to 300.

#### Single Receiver - Dual Frequency Band Inclined Orbit Satellite AGC Setup

The setup procedure described above was for the case where a single satellite receiver is connected to the controller, and the user is interested in tracking only satellites of a single frequency band (either C or Ku). A slight increase in complexity occurs if the user must be able to track both C and Ku band inclined orbit satellites. This is because the same AGC channel is used for both frequency bands, and therefore the OFFSET and GAIN pot adjustments for that channel must be made so as to accommodate both frequency bands. At the heart of the problem is the fact that the signal strength (as seen by the receiver's AGC circuits) will vary with the frequency band selected due to differences in antenna gain, LNB gain, and the differences in output power between C, Ku, and L band satellites.

The adjustment procedure for the dual band case is very similar to the single band case described above. The following paragraphs describe the modifications required to adapt the single receiver - single band procedure, to the single receiver - dual band case.

1. The procedure is similar to step 1 above except that the user should align the antenna with a strong C band and a strong Ku (or L) band satellite. The voltages for each frequency band should be recorded.
2. Similar to step 2 above except that both C and Ku (or L) band AGC voltages are obtained when the antenna is looking at nothing.
3. Similar to step 3 above. The only modification is that the user should select the frequency band whose 'on satellite' and 'off satellite' receiver AGC voltage difference is the greatest to make the determination of which AGC channel to use.
- 4-5. No changes from steps 4 and 5 which are outlined above.
6. As outlined above, in the next few steps the user will adjust the GAIN and OFFSET pots of the AGC channel that is connected to the receiver. The difference is that in steps 7 through 9 the term 'on satellite' must be replaced with 'on satellite, strong band' and the term 'off satellite' must be replaced with 'off satellite, weak band'. These terms are described below.

The term 'on satellite, strong band' refers to the case when the antenna is aligned with a satellite of the frequency band that has the greatest gain. For a POSITIVE AGC polarity receiver this is the band for which the greatest voltage was recorded in step 1. For a NEGATIVE AGC polarity receiver, this is the band for which the lowest voltage was recorded in step 1.

The term 'off satellite, weak band' refers to the case when the antenna is positioned off of any satellite and the receiver is tuned to the frequency band which has the lowest gain. For a POSITIVE AGC polarity receiver this is the frequency band for which the lowest voltage was recorded in step 2 above.

For a NEGATIVE AGC polarity receiver this corresponds to the frequency band for which the greatest voltage was recorded in step 2 above.

7. Similar to the step 7 outlined above. In place of 'off satellite' use the term 'off satellite, weak band' as described above.
8. Similar to the step 8 outlined above. In place of 'on satellite' use the term 'on satellite, strong band' as described above.
9. Similar to the step 9 outlined above. In place of 'off satellite' use the term 'off satellite, weak band' as described above.
10. Similar to the step 10 outlined above except that jogging the antenna 'on satellite' and then slightly off should be performed for each frequency band to obtain both the AGC C Band Threshold and the AGC K/L Band Threshold. Both of the threshold values should be entered into the controller via CONFIG mode as outlined above.

### Using Two AGC Channels

Connecting a second receiver to the controller is straightforward. The controller AGC input channel GAIN and OFFSET adjustments have enough range to handle any possible receiver AGC scheme, as long as the AGC level is less than six volts. In step 3 of the adjustment procedure, the installer is instructed to select the controller AGC input channel based on the range of the receiver's AGC output. AGC input channel 1 is designed to handle 'small' AGC signal swings, and AGC input channel 2 is designed for 'large' AGC signal swings. There is enough adjustment range, however, so that either channel may be connected to any receiver AGC output.

If two receivers are used, both must have the same AGC polarity, and the GAIN and OFFSET pots of each channel must be adjusted so that the same threshold values are appropriate for each channel. The controller will use as its AGC input the stronger of the two signals. All pot adjustments will have to take place in LIMITS mode, because this is the only mode where the voltages that correspond to each AGC channel may be viewed simultaneously and unambiguously.

### Amplifier Gain vs. Frequency Characteristics

An amplifier's gain vs. frequency characteristic, or gain flatness, is the variation of the amplifier's gain with changing frequency. The ideal response is to have a flat gain characteristic (the gain does not vary with frequency). Amplifiers with poor gain flatness characteristics can cause problems for the tracker. This section describes a simple test (no equipment required) that the user can carry out to check the receiving system's gain flatness.

There are four places in a satellite receiving system that may have gain flatness problems that can affect the operation of the tracker. These are the LNB, the coaxial cable connecting the LNB to the receiver, line amps (or bullet amps) inserted in the 950 - 1750 MHz IF, and the receiver's IF or AGC stages. If a spectrum analyzer is connected into the receiver's block IF line, the gain flatness of the LNB and any line amps present can be observed. When the antenna is pointed away from any satellite, the spectrum analyzer displays the received noise, which should be constant with frequency. If the display is not a horizontal line then some gain variation with frequency is present.

To understand how a poor gain flatness characteristic can cause problems, remember that the purpose of the AGC input is to let the controller determine whether a satellite signal is present or not, and to provide relative signal strength information when peaking the antenna. A signal is assumed to be present whenever the AGC input is above the threshold level for whichever band - C or Ku or L - has been selected. When the receiver is tuned to various transponders, gain flatness problems could cause the AGC signal to be above the threshold, when in fact no satellite signal is present. For certain transponders, gain flatness problems could also cause the controller's AGC input scaling network to be saturated when the antenna is aligned with a strong satellite, making it impossible for the controller to detect changes in signal strength when attempting to peak the antenna.

To test the gain flatness of the satellite receiver, perform the following procedure. The procedure assumes a single receiver, single frequency band system.

1. Position the antenna well off of any satellite. Tune the receiver to each transponder. Make sure that the signal strength reading is below the threshold assigned via CONFIG mode.
2. Align the antenna with a strong satellite. Tune the receiver to each active transponder on the satellite. Make sure that the signal strength is well above the threshold and below 999.

If the system fails either of the tests above, then the user can either attempt to correct the problem by readjusting the GAIN and OFFSET pots (using the procedure outlined earlier), or by correcting the gain flatness problem. Most gain flatness problems can be traced to a problem with the coaxial cable connecting the antenna to the receiver (sometimes called a 'suck-out') or to bullet amplifiers. Some bullet amplifiers have been observed to have really terrible gain flatness characteristics.

To perform the above tests on a dual frequency band system, repeat the test for each frequency band. On a dual receiver system, simply perform the test on each receiver. On a dual frequency system the tests should be performed with the controller in LIMIT mode, so that there is no confusion as to which AGC input channel the displayed signal strength reading corresponds to.

#### 4.4.2 Initializing the Antenna Scale Factors

The azimuth and elevation scale factors refer to the mapping of antenna azimuth and elevation position counts to antenna azimuth and elevation angles. The elevation scale factor is entered by the user. The azimuth scale factor can either be specified by the user, or it can be derived from the position and longitude data of adjacent geostationary satellites. The antenna scale factors are specified via the Azim Constant and Elev Constant CONFIG mode items.

The Azim Constant and Elev Constant items are specified in position counts per radian. A radian is a unit of angular measure. 2 times PI radians equals 360 degrees where PI is equal to 3.1415... . To convert degrees to radians, multiply the degree value by 0.0174532. To convert radians to degrees, multiply the radian value by 57.295. Note that the RC2000 counts both rising and falling edges of the position pulses so that a single position pulse generates 2 position counts.

NOTE: The scale3.exe program described in section 3.7 – Angle display of Az/EI position data calculates the azimuth and elevation scale factors

##### Elevation Scale Factor

This section describes the method used to determine the elevation scale factor needed to initialize the Elev Constant CONFIG mode item. The method is based on moving the antenna in elevation over a known angle (as determined by an inclinometer) and obtaining the number of counts which corresponds to the angular movement. A hand calculator is then used to determine the Elev Constant.

Here is the procedure:

1. Identify a location on the antenna to place the inclinometer. The location on the mount should be selected so that one degree of movement about the elevation axis registers as one degree on the inclinometer. It is best to use an inclinometer that has a magnetic base. These are available from hardware stores.
2. Record the elevation position count and the reading of the inclinometer. These will be designated CNT\_1 and DEG\_1, respectively.

CNT1 \_\_\_\_\_ DEG1 \_\_\_\_\_

3. Jog the antenna in elevation. It is recommended that the antenna be moved 15 to 20 degrees in elevation. Record the elevation position count and the inclinometer reading. These will be designated CNT\_2 and DEG\_2.

CNT2 \_\_\_\_\_ DEG2 \_\_\_\_\_

The elevation region over which the measurements are made should correspond to the range of elevation angles which will be encountered in operation (i.e. the elevation values over which the satellites will be found).

4. Use the following formula to calculate the Elev Constant:

$$((CNT\_2 - CNT\_1) / (DEG\_2 - DEG\_1)) * 57.29$$

$$(\text{_____} / \text{_____}) * 57.29 = \text{_____} \text{ (Count per Radian)}$$

If the result is negative, change the sign to positive.

Here is an example:

Place the inclinometer on one of the back support struts of the antenna. The antenna is located near Kansas City, Kansas, USA (latitude 39 N, longitude 94 W). A satellite located longitude 94 W has an elevation look angle of 44 degrees relative to the horizon. The normal range of elevation movement is 20 to 45 degrees.

Positioning the antenna at an elevation angle of 21 degrees, the count is 435. Record CNT\_1 as 435 and DEG\_1 as 21 degrees. Move the antenna up in elevation to an angle of 43 degrees where the count is 1272. Record CNT\_2 as 1272 and DEG\_2 as 43. Perform the calculation:

$$((1272 - 435) / (43 - 21)) * 57.29$$

$$\text{simplify to obtain... } (837 / 22) * 57.29 = 2179.62.$$

Round this up to 2180 and enter this value at the Elev Constant CONFIG mode prompt.

#### Elev Scale Factor from Manufacturer's Specifications

If the antenna manufacturer gives an elevation position pulses per degree specification for the antenna, simply multiply the value by 2 to obtain 'elevation position counts per degree' (because the RC2000 counts both the rising and falling edges of the position pulses). Multiply this 'position counts per degree' value by 57.29 to obtain 'position counts per radian'. Round to the nearest whole number value to obtain the Elev Constant CONFIG mode item.

$$\text{_____} * 2 * 57.29 = \text{_____} \text{ (counts per radian)}$$

#### Azimuth Scale Factor

The user has the option of providing the controller with a value for the azimuth scale factor via the Azim Constant CONFIG mode item. If the user does not provide a value for the Azim Constant item, the controller will determine one based on the locations of geostationary satellites (with sufficient separation) in the vicinity of an inclined orbit satellite that the user wishes to track.

Normally, the user should let the controller determine the scale factor. The user must specify an azimuth scale factor if it is impossible to program a pair of geostationary satellites into the controller's memory. The Azim Constant CONFIG mode item should be set to 0 to specify to the controller that it should calculate the scale factor. If the Azim Constant is set to a non-zero value, that value is used as the azimuth scale factor.

If is necessary for the user to specify the azimuth scale factor, there are a couple of methods available to determine the proper value. The most straightforward method is to obtain the azimuth axis 'degrees per position pulse' value from the antenna manufacturer. Please refer to the discussion above on determining the scale factor based on antenna manufacturer's specifications. The procedure for obtaining the azimuth scale factor from the manufacturer's data is identical to the procedure outlined for the elevation axis.

An instance of when it is not possible to program a pair of geostationary satellites (and the appropriate information may not be available from the manufacturer) may occur for a weather satellite where there are not 2 geostationary satellites available at the weather satellite frequency. It is still possible to determine the scale factor if satellite pointing data is available for a similar antenna mount and actuator set. Here, satellite pointing data refers to azimuth position counts for a pair of geostationary satellites at known longitudes. If the position counts were not obtained with an RC2000, the user must determine whether the controller used to obtain the data accumulates position pulses or position pulse edges (as the RC2000

does). Multiply position pulse data by two to obtain position count data - see the discussion above on obtaining the elevation scale factor from manufacturer's data for the distinction between position pulses and position counts. The following calculation yields an approximate value for the azimuth scale factor that generally gives adequate results.

In the following formula the position count and longitude associated with the first satellite is designated CNT\_1 and LON\_1, respectively. The position count and longitude value associated with the second satellite is referred to as CNT\_2 and LON\_2.

Here is the formula...  $(CNT_1 - CNT_2) / (LON_1 - LON_2) * 48$

Round to the nearest whole number and convert negative numbers to positive numbers. Note that in the denominator of the above expression (LON\_1 - LON\_2) refers to the difference in longitude values between the two satellites. If LON\_1 has a value of 5 degrees West and LON\_2 has value of 7 degrees East, then (LON\_1 - LON\_2) is 12 (= 7 + 5). If westerly longitude values are treated as negative numbers the formula works fine.

$$\left( \frac{\text{_____} - \text{_____}}{\text{_____} - \text{_____}} \right) * 48$$

= \_\_\_\_\_ (counts per radian)

Change the sign to convert to a positive value. Enter at the Azim Constant CONFIG mode prompt.

Here is an example...

	azimuth position count	longitude
satellite 1	1520	7 degrees West
satellite 2	944	5 degrees East

Here is the calculation...  $(1520 - 944) / (-7 - 5) * 48$   
simplifying yields  $(576) / (-12) * 48 = (-2304)$

#### 4.4.3 CONFIG Mode Data

This section briefly describes each of the CONFIG mode items and how they relate to the tracking system. The names of CONFIG mode items appear in italics. The installer should go through this section and enter in the relevant data. Be sure to terminate each entry with the ENTER key. If an entry is terminated by depressing the SCROLL keys, the data entered by the user is not stored in non-volatile memory. After all of the data has been entered, the user should go through the data items again to verify that all entries were properly recorded.

The *AutoPol Enable* and *AutoPol Vpol Level* items are described in section 3.6. In TRACK mode the AutoPol feature works the same as it does in the other modes. When a movement is in progress while TRACK mode is active, the AutoPol signal may not be immediately recognized. It will be recognized when the movement ceases. Note that not all versions of the controller support polarization control.

The *Remote Mode Enable*, *Comm Address*, and *Comm Baud Rate* CONFIG mode items control the operation of the REMOTE mode system. If REMOTE mode is enabled, commands may be received via the serial port while tracking an inclined orbit satellite and front panel control of polarization is disabled. While TRACK mode is active, a remote command received which specifies an azimuth or elevation movement will cause REMOTE mode to activate - no tracking occurs in REMOTE mode. A remote command which is received that does not involve azimuth or elevation movement, will be serviced by TRACK mode without disrupting the tracking operation in progress.

The *Azim Slow Speed* and the *Elev Slow Speed* codes are discussed in section 3.4. These speed codes should be initialized because all movement in TRACK mode occurs at slow speed.

The *Simultaneous Az/EI Enable* CONFIG mode item is not relevant in TRACK mode as no movements in TRACK mode occur about each axis simultaneously. This item is only applicable to movements that occur in AUTO mode.

The *Angle Display Enable*, *Display Az Gain*, *Display Az Offset*, *Display El Gain*, and *Display El Offset* CONFIG mode items are used to display the azimuth and elevation positions in an angle format. These items are determined using the procedure outlined in section 3.7. It is not necessary for the angle display feature to be enabled for the tracking system to operate.

The *Rotating Feed Present*, *Rotating Feed CW Limit*, *Rotating Feed CCW Limit*, and *Rotating Feed Jog Duration* CONFIG mode items do not directly affect the tracking system. The *Rotating Feed Present* item should be configured during installation. Note that not all versions of the software support polarization control.

The azimuth and elevation drive options consist of the *Az/EI Drive Options Enable*, *Az/EI Fast Slow Threshold*, *Az/EI Auto Retry Attempts*, *Az/EI Fast Deadband*, *Az/EI Slow Deadband*, *Azimuth Coast Threshold*, *Azimuth Max Position Error*, *Elev Coast Threshold*, and the *Elev Max Position Error* CONFIG mode items. These items are described in section 5.10. For inclined orbit tracking, it is generally best to set the Max Position Error CONFIG mode item to 0.

The *Time* and *Date* are entered via CONFIG mode. The use of time and date information by the tracker is described in section 4.3.4. Note that once a track is established for a satellite the *Time* and *Date* should not be changed. If this is a problem, the user might set the *Time* and *Date* to Universal Coordinated Time (formally called Greenwich Mean Time - GMT). Please refer to section 4.3.4.

The *AGC Polarity Flag*, *AGC C Band Threshold*, and the *AGC K/L Band Threshold* CONFIG mode items are discussed in section 4.4.1. Please refer to that section for more information on these items.

The *Antenna Latitude* and *Antenna Longitude* are required by the tracking algorithms to predict the apparent motion of the satellite. The data is entered in a degrees.tenths\_of\_degrees format. Most maps show latitude and longitude data in a degrees.minutes format. Below is a table of minutes versus tenths\_of\_degrees.

<u>minutes</u>	<u>degrees</u>
06	0.1
12	0.2
18	0.3
24	0.4
30	0.5
36	0.6
42	0.7
48	0.8
54	0.9

The latitude and longitude data entry must also specify a direction. For latitude the options are North or South, and for longitude the options are East and West. Locations in North America and South America have westerly longitudes, while locations in Asia have easterly longitudes. Section 2.1 describes the keys used to specify the direction associated with latitude or longitude data entry.

The *Antenna Size* parameter specifies the antenna diameter in centimeters. Use the table below to convert feet or meters into centimeters.

<u>Feet</u>	<u>Meters</u>	<u>Centimeters</u>
5.9	1.80	180
8	2.44	244
10	3.05	305
12	3.66	366
15	4.57	457
20	6.10	610
23	7.00	700
24	7.32	732

The initialization of the *Azimuth Constant* and *Elev Constant* CONFIG mode items are used to specify scale factors, and were described in Section 4.4.2.

The *Max Track Error* and *Search Width* CONFIG mode items are discussed in section 4.2. The default values are 10 and 3, respectively. The *Max Track Error* is specified in tenths of a dB. When initiating a track on an inclined orbit satellite for the first time, it is probably best to leave these parameters at their default values. See the section on tracking problems at the end of this chapter for more information on the *Max Track Error* parameter.

The *Search Enable* CONFIG mode item is used to enable or disable the Intelli-Search feature when the SEARCH sub-mode is active. When disabled, the SEARCH sub-mode will simply prompt the user to manually jog the antenna (via the front panel) back onto the satellite and hit the ENTER key. When the ENTER key is pressed, control will transfer to the STEP TRACK sub-mode. The Intelli-Search should be disabled for transmit applications, or when the RC2000 is interfaced to an antenna that moves very slowly.

#### 4.4.4 Initiating a Track on an Inclined Orbit Satellite

This section describes the process of initiating a track on an inclined orbit satellite. It is assumed here that the user has entered the configuration data outlined in sections 4.4.1 through 4.4.3 into the controller, and that there are no alarm messages flashing on the bottom row of the display. If there are active alarms, they must be cleared before initiating a track on an inclined orbit satellite.

The steps required to initiate a track are very similar to the procedure used to program a geostationary satellite into the controller's memory. A track is initiated from SETUP mode as follows:

1. Go to SETUP mode and use the jog keys to manually align the antenna with the satellite. The polarization can be jogged via the POL CW and POL CCW keys.
2. Use the SCROLL keys to select the satellite name. Press ENTER to assign the name to the satellite. If the name is not in the list, go to step 3.
3. If the satellite name was found, skip this step. If the name was not in the list, select the USER entry. Then use the SCROLL keys to scroll through the alphanumeric list to key in the name of the satellite. Press the ENTER key to select each letter/number, and press ENTER at the "\*" to terminate the entry. A blank space can be entered by pressing SCROLL UP once and SCROLL DOWN once at the "\*" prompt.
4. 'IS THIS AN INCLINED ORBIT SAT'. Hit the YES key in response to this question.
5. 'ENTER SAT LON LLL.L'. Use the number keys and the decimal point to enter the numeric portion of the satellite longitude; i.e., if the longitude is 100.5 West, key in '100.5'. Terminate the entry of the numeric portion of the satellite longitude by hitting the ENTER key. The BKSP key may be used to backspace over any incorrectly entered data any time before the ENTER key is pressed.

The user is next prompted to enter the direction associated with the longitude entry. Hit the 4 key to specify an East longitude, and hit the 6 key for a West longitude. Hit the ENTER key to terminate the entry.

6. 'SELECT BAND 0-C,1-K,2-C&K,3-L'. If the satellite is a hybrid which has both C and Ku band transponders, select 2. Otherwise, key in the appropriate band designation.
7. 'SAT INCLINATION (2-16 DEG):' See the Appendices for a list of inclined orbit satellites and a nomograph which may be used to determine the inclination of the satellite's orbital plane to the earth's equatorial plane. Key in the appropriate value, followed by ENTER. Note that very few communications satellites have an inclination greater than 6 degrees. If you are unsure of the satellite inclination, try 5 degrees.
8. The user is next prompted to specify the horizontal and vertical polarization values for the satellite. Use the CW and CCW keys to skew the polarization, and the H and V keys to set the polarization. (Values must be specified for the horizontal and vertical polarizations even if the antenna has no polarization adjustment. If the antenna has no polarization adjustment, make sure that the Rotating Feed Present CONFIG mode item is set to NO. The controller will then assume that a polarotor is connected to the antenna. A polarotor is controlled in an open loop fashion, i.e. the controller sends control signals to the polarotor and does not receive any feedback from the polarotor - the controller cannot tell whether a polarotor is present or not.) NOTE: For feeds that can simultaneously receive both H and V polarization both 'H' and 'V' polarization values should be the same. Make sure that

both values are peaked up on different transponders. ANOTHER NOTE: Not all versions of the software support polarization control.

9. 'INITIAL TRACK POL (H OR V)?' Press the appropriate key for the polarization of the initial track. Note that not all versions of the software support polarization control.
10. Control will transfer to TRACK mode. 'TRAK' will be displayed in the upper right hand corner of the display. If the user designated a hybrid satellite (both C and Ku band), the following prompt appears: 'BAND? 0-C 1-K:'. Select the appropriate band. The band designation for a hybrid satellite may be changed via the TRACK menu. The band that the controller assumes is active is displayed in the upper right hand corner of the display just to the right of the 'TRAK' banner.
11. 'INITIALIZING - PLEASE WAIT' will appear, then the controller will switch to STEP TRACK sub-mode. The controller will STEP TRACK for 23 hours, 56 minutes, and 4 seconds while building up the program track table. When program track data is available for the current sidereal time, control will transfer to the PROGRAM TRACK sub-mode. If the satellite transponder goes down while step tracking, the controller will switch to SEARCH mode and attempt to require the satellite.
12. A number of errors can be detected during the TRACK mode initialization process. The SCALE FACTOR error indicates that the Azim Constant CONFIG mode item is set to zero and two geostationary satellites with sufficient spacing are not available which allow the azimuth scale factor to be derived. The SYSTEM error indicates that an alarm message is flashing on the bottom row of the display.
13. If the Search Enable CONFIG mode item is enabled, a good test of the tracking system is to exit TRACK mode by depressing the MODE key, and then selecting the satellite via AUTO mode to reacquire the satellite. AUTO mode will prompt for the desired polarization and transfer control to the SEARCH sub-mode of TRACK mode. A search will be performed and when the satellite is found, STEP tracking will resume. Note that not all versions of the software support polarization control.

Please review the description of TRACK mode in chapter 5 for a complete explanation of each of the TRACK mode submodes and the TRACK mode menu system. Every field of every display screen is described in that section.

#### 4.4.5 Tracking Problems

This section discusses problems that can occur while tracking an inclined orbit satellite. TRACK mode contains an ERROR submode, which displays an error message when it is active. Chapter 7 discusses all of the possible errors that can occur. This section discusses the more common problems.

The LIMIT error occurs when an antenna limit (either azimuth or elevation) is encountered when tracking an inclined orbit satellite. This error will only occur while the STEP TRACK or PROGRAM TRACK submodes are active. The SEARCH submode will not attempt to move outside of the azimuth or elevation limits. This error generally means that the azimuth or elevation (usually elevation) limits are not set wide enough.

A PEAK LIMIT error indicates that the controller had to move the antenna too far during a STEP TRACK peaking operation. The maximum movement of the antenna from the starting position for a STEP TRACK operation is limited. This is to prevent the antenna from peaking up on an adjacent satellite. This problem can be caused by a number of situations:

1. Specifying too large of an antenna diameter, or specifying Ku band when tracking a C band satellite. These cause the controller to calculate too narrow of an antenna beamwidth. This beamwidth is used to determine the maximum allowable movement from the starting position for a STEP TRACK operation.
2. Specifying too small of a satellite inclination. In STEP TRACK mode, the controller performs peakups often enough to avoid exceeding the maximum antenna pointing error specified by the Max Track Error CONFIG mode item. If the specified satellite inclination is too small, the peakups will not occur often enough, and the antenna may move far enough during a peakup to trigger the PEAK LIMIT error.
3. The C Band AGC Threshold or the K/L Band AGC Threshold is set too low. If the threshold values are set too low, when the transponder powers down, the AGC signal of the receiver may be above the

threshold when the antenna is looking at noise. In this case the controller would mistakenly assume that the satellite signal is present, and attempt to peak up on the noise.

4. If the error occurs during a pickup operation while the PROGRAM TRACK sub-mode is active, it may be that the Update Check Interval TRACK mode MENU item is set too large.
5. There may not be a sufficient number of position counts per degree of antenna movement about one of the antenna axis. The controller cannot move less than one count. If a move of less than one count is specified the antenna will round the step size up to one count. Note that all systems will have one count of play or looseness in the antenna - see the next section. A good rule of thumb is that there should be 10 position counts over the antenna's 3-dB beamwidth for each axis.
6. Play or looseness in the mount can cause many problems. The user can test for play by shaking the antenna. Another test is to see if the antenna peaks on a satellite at different count values depending on which way the antenna approached the satellite. Here's an example. In one case the peak is approached by jogging the antenna up and the peak occurs at 110 counts. In another case the peak is approached by jogging the antenna down and the peak occurs at 103 counts. This indicates that there are 7 counts of play in the system. The solution is to get rid of the play. In some cases, increasing the Max Track Error parameter can help. In general, however, the controller is not very tolerant of looseness in the mount.

If a linear actuator is used to drive the antenna about an axis, it usually forms one side of a triangle. As the length of the linear actuator changes, the opposite angle varies and the pointing angle of the antenna is changed. If the linear actuator has some play in it, the change in the antenna pointing angle due to the play in the actuator can be minimized if the other sides of the triangle are made longer. In some cases, the ball pivot often found on one side of the linear actuator is also loose. Anything which can be done to tighten up the ball pivot will help.

It is usually best to choose an antenna mount that uses longer linear actuators, because the 'sides of the triangle' formed by the mount and the linear actuator are longer. With longer sides of the triangle, looseness in the linear actuator translates into smaller antenna pointing angle variation.

See section 7.3 - Troubleshooting for more track related errors.

## 4.5 Inclined Orbit Satellite Setup Checklist

1. Connect the AGC output from the satellite receiver to one of the controller AGC input channels. Determine the AGC Polarity. Enter the polarity into the controller via CONFIG mode.
2. Adjust the GAIN and OFFSET pots for the selected AGC channel so that when the antenna is aligned with a strong satellite the signal strength level is around 650, and when the antenna is well off of any satellite the signal strength level is around 75.
3. Determine the values for the AGC C Band Threshold and/or the AGC K/L Band Threshold, depending on which frequency bands are used. The threshold values are used to determine whether or not a satellite signal is present.
4. With the antenna positioned well away from any satellite, tune the satellite receiver across all transponders to verify that the noise floor is below the threshold.
5. Determine the elevation scale factor. Determine the number of 'position counts per degree' and multiply this value by 57.29 to get the value for the Elev Constant CONFIG mode item. Note that the RC2000 counts both the rising and falling edges of each position pulse.
6. With the antenna aligned with a strong satellite tune the satellite receiver across all bands, and verify that the signal strength level does not reach saturation and remains above the threshold.
7. Enter in the data for the following via CONFIG mode: Antenna Latitude and Longitude, the Time and Date, and the Antenna Size (in centimeters). Note - once the time is set and the controller is tracking, do not change the time (i.e. Standard to Daylight Savings), as this will invalidate the data in the track table.

8. Go to SETUP mode and program in an inclined orbit satellite. As a test of the search algorithm, the user can go to AUTO mode and select the inclined orbit satellite from the list of satellites programmed into non-volatile memory. The controller should then perform a search. When the search is complete, if the satellite is found, step tracking will resume. An automatic search will only be performed if the Search Enable CONFIG mode items is set to 1.

## Chapter 5 MODES IN-DEPTH FUNCTION DESCRIPTION

The Operational Mode Group consists of four modes: MANUAL, AUTO, REMOTE, and TRACK. Programming Mode Group consists of several modes: LIMITS, SETUP, RESET, DELETE, RE-SYNC, and CONFIG.

### 5.1 MANUAL Mode

```
AZ:178.4 EL: 44.2 PL: 15 H S:635 MANUAL
SBS 2          97.0 W      SPEED:FAST
```

This mode allows the user to manually jog the antenna in azimuth, elevation, and polarization using the AZ CCW, AZ CW, EL DOWN, EL UP, POL CCW, and POL CW keys. The H and V keys will select the preset horizontal and vertical polarizations of the satellite that was last a target of the auto-move system. Note that manual polarization control is available only when the AutoPol feature is disabled. When AutoPol is enabled, the 'PL:' banner in the MANUAL mode display will change to 'AP:'. The AutoPol system is described in section 3.8. It should be noted that not all versions of the controller support polarization control.

The 'S:' field displays the stronger of the two receiver AGC voltages available to the controller via the AGC1 and AGC2 terminals on the J1 connector on the back of the controller. The AGC Adjustment procedure is described in section 4.4.1 - AGC Adjustment and Configuration.

When the antenna is in the vicinity of a satellite which was the target of the last Auto Move operation, that satellite name and longitude will be displayed. When the current polarization setting is in the vicinity of the preset horizontal or vertical polarizations of the satellite that was the target of the last Auto Move operation, either 'H', 'h', 'V', or 'v' will be displayed. The capital letters will be displayed if the satellite name is displayed, and the lower case letters if the satellite name is not displayed. If there is no polarization indication, it means that the antenna's current polarization setting is somewhere in between the preset polarization values.

### 5.2 AUTO Mode

```
SELECT A SATELLITE: PANAMSAT-1      AUTO
USE SCROLL UP/DOWN, ENTER TO SELECT
```

Satellites that have been stored in the controller's non-volatile memory (via SETUP mode) can be recalled via AUTO mode. Azimuth, elevation, and horizontal and vertical polarization presets for up to 35 satellites may be stored in non-volatile memory. Here is the procedure for recalling a satellite:

1. Toggle the MODE key to enter AUTO mode.
2. Use the SCROLL UP and/or SCROLL DOWN keys to scroll through all of the satellites stored in non-volatile memory. Press the ENTER key to select the desired satellite.
3. After the satellite has been selected, the controller will prompt the user to specify the desired polarization if the AutoPol feature is not enabled. If AutoPol is enabled, the polarization will be controlled according to the digital level present at the H/V input terminal on the back of the controller.
4. Antenna movement can be stopped at any time by pressing the STOP key. Simultaneous azimuth and elevation movement can be enabled via the Simultaneous Az/EI CONFIG mode item. If simultaneous Az/EI movement is not enabled, the controller will first position the antenna in azimuth and then elevation. The antenna movement will be controlled by the CONFIG mode items outlined in section 5.10.7 - Azimuth and Elevation Drive Options.
5. When the automatic move is completed, control will transfer to MANUAL mode if the target is a geostationary satellite. If the target of the automatic move is an inclined orbit satellite, TRACK mode receives control.

**NOTE: If a polarotor is installed in the system, when the power is turned off, the polarotor probe may move slightly away from the last position it was commanded to move to. When power is reapplied, the polarotor probe will move back to the position it was at before power was removed. For this reason, always leave the controller on.**

## 5.3 REMOTE Mode

```
AZ:178.4 EL: 44.2 PL: 15 H S:635 REMOTE
SBS 2
```

In REMOTE mode the controller only responds to commands received via the built-in RS-422 serial port. REMOTE mode can only become active if the Remote Mode Enable CONFIG mode item is enabled. If REMOTE mode is enabled, it can become active either via the MODE key or in response to the reception of a valid command via the serial port. Note that TRACK mode can process certain serial port commands. The REMOTE mode screen is similar to the MANUAL mode screen. The only differences are that the satellite longitude and 'SPEED:' banners are not displayed. Only the MODE key is active when REMOTE mode is active.

## 5.4 TRACK Mode

```
AZ:178.4 EL: 44.2 PL: 73 V S:621 TRAK K
GSTAR 3 PROGRAM IDLE 15.56.0-MENU
```

TRACK mode is invoked either from SETUP mode or AUTO mode to track inclined orbit satellites. TRACK Mode consists of 4 sub-modes: STEP, PROGRAM, SEARCH, and ERROR. The track sub-mode that is currently active is displayed to the right of the satellite name. Status information relating to the submode that is currently active is displayed to the right of the sub-mode. The tracking algorithms along with these sub-modes are described in section 4.2. The frequency band (L, C, or K) of the transponder which the controller assumes that it is tracking is displayed in the upper right hand corner of the display.

Whenever the 'IDLE' message is displayed on the bottom row of the display:

- the current time is displayed in an hours.minutes format (00.00 to 23.59),
- the '0-MENU' message will be displayed to the right of the time display if Expert Access is enabled via CONFIG mode, and
- the POL CCW, POL CW, H, and V keys may be used to adjust the polarization if remote mode has been disabled.

The '0-MENU' display indicates that the user can hit the 0 key to activate the TRACK mode menu. From the TRACK mode menu the user can view the contents of the track table, see the current sidereal time and the scale factors for the satellite currently being tracked, modify certain track parameters, and initiate certain track operations. See section 5.4.5 for a description of the TRACK mode MENU system.

If TRACK mode receives control via SETUP mode, the controller will perform some data initializations and switch to the STEP track sub-mode. The SCALE FACTOR and SYSTEM errors may be detected during the initialization. These are described in chapter 7 - TRACK Mode Errors.

If TRACK mode receives control via AUTO mode, the controller will check for the presence of track table information for the current sidereal time. If track table information is found, the controller will activate the PROGRAM track sub-mode. If track table information is not available, the SEARCH sub-mode will receive control.

### 5.4.1 SEARCH Sub-mode

The following conditions lead to activation of the SEARCH sub-mode:

- TRACK mode is entered from AUTO Mode and program track data is not available in the track table for the current sidereal time;
- the STEP TRACK sub-mode is active and the satellite transponder goes down;

3. or PROGRAM TRACK mode is active, and the AGC inputs indicate that a satellite signal is not present when the sidereal time advances to a value for which track data is not available in the track table.

The behavior of the controller when the SEARCH sub-mode is active is determined by the state of the Search Enable CONFIG mode item. If the search is disabled, when the SEARCH sub-mode activates, the controller will prompt the user to manually align the antenna with the satellite (by using the jog keys) and hit the ENTER key to transfer control to the STEP TRACK sub-mode. If the sidereal time advances to a value for which track data is available in the track table, control will transfer to the PROGRAM TRACK sub-mode.

If the Search Enable CONFIG mode item is enabled, the controller will perform a search for the satellite using the Intelli-Search algorithm. When the search is performed, the controller will sweep the antenna in a serpentine shaped pattern over the entire region where it has calculated that the satellite may be found. The width of the search box is controlled by the Search Width CONFIG mode item. If during the search a signal is detected above the appropriate AGC threshold (either C or K/L) after the entire search region has been traversed the antenna will return to the position where the signal was detected and control will transfer to the STEP TRACK sub-mode. If the search is unsuccessful, the controller will wait for Search Retry minutes before initiating another search. The Search Retry parameter may be inspected and modified via the TRACK MENU - Modify menu. Additional information concerning the Search sub-mode is available in section 4.2.3. Note that for transmit applications it is generally advisable to disable the automatic search feature.

When the SEARCH sub-mode is active, the following messages will be displayed to the right of the satellite name on the bottom row of the display.

SEARCH - A search is in progress. If a satellite is found, the STEP track sub-mode activates.

SEARCH IDLE - A search has been performed and a satellite was not found. The controller is waiting to perform another search. The TRACK MENU function may be invoked to initiate another search, or to change the Search Retry Interval. If the sidereal time advances to a value for which track table data is available, the PROGRAM track sub-mode will activate.

#### 5.4.2 STEP TRACK Sub-mode

When the STEP track sub-mode is active, the following actions can occur:

1. The antenna is periodically jogged in elevation and then azimuth to peak up the received signal strength.
2. The controller compiles the track table.
3. Control will transfer to the PROGRAM track sub-mode if the sidereal time advances to a value for which track table information is available.
4. If the signal strength indicates that the transponder has powered down, the controller will wait a short while for the transponder to come back online before activating the SEARCH sub-mode.
5. The TRACK MENU system may be used to immediately trigger a peaking operation. See section 5.4.5 for a description of the TRACK MENU system. A more detailed description of the STEP track algorithm is given in section 4.2.1.

When the STEP sub-mode is active, the following messages may be displayed:

STEP SIG OK IDLE - The AGC input indicates that a satellite signal is present and the controller is waiting to perform another peaking operation.

STEP SIG OK PEAKING - The controller is jogging the antenna to find the maximum signal strength. The step size is determined by the Max Track Error CONFIG Mode item, the antenna size, and the frequency band.

STEP NO SIG IDLE - The AGC input indicates that a satellite signal is not present (the AGC level is below the appropriate threshold level). The controller will wait approximately 5 minutes for the AGC to return before activating the SEARCH sub-mode.

### 5.4.3 PROGRAM TRACK Sub-mode

In the PROGRAM track sub-mode, the controller positions the antenna based on values stored in the track table. The controller will also periodically perform a peaking operation similar to that which occurs in the STEP track sub-mode. If the difference between the peakup position and the position stored in the track table is greater than the error specified by the Max Track Error CONFIG mode item, the update flag for each track table entry is set. When a receiver AGC signal is present and the sidereal time is equal to that associated with a track table entry whose update flag is set, a peakup occurs, the peakup azimuth and elevation position count values are placed in the track table, and the update flag for that track table entry is reset.

When the PROGRAM track sub-mode is active, control can switch to either the STEP track or SEARCH sub-modes when the sidereal time advances to a value for which track table data is not available. When this occurs, the STEP track sub-mode will activate if a receiver AGC signal is available, otherwise, control will transfer to the SEARCH sub-mode. A more detailed description of the PROGRAM track sub-mode may be found in section 4.2.2.

The TRACK MENU system may be used to immediately trigger a reposition of the antenna to the azimuth and elevation position derived from the track table, and to view the contents of the track table. The TRACK MENU system also allows the user to specify the time interval between peakup operations that check the accuracy of the data in the track table. Additionally, the TRACK MENU system allows the user to clear the track table. The menu system is described in section 5.4.5.

When the PROGRAM sub-mode is active the following messages may be displayed:

PROGRAM IDLE - The PROGRAM track sub-mode is active. The controller is waiting to reposition the antenna.

PROGRAM REPOSITION - The controller has determined that the antenna pointing error is greater than that specified by the max track error parameter, and is currently repositioning the antenna to a position derived from the track table.

PROGRAM PEAKING - The controller is performing a step track operation to either check the accuracy of or to update a track table entry.

### 5.4.4 TRACK Mode - ERROR Sub-mode

The ERROR sub-mode activates whenever an error is detected. No tracking occurs while the ERROR submode is active. The only way to exit from the ERROR submode is to exit TRACK mode by hitting the MODE key, or via a Track Reset command received by the serial port. The various track mode errors are described in section 7.2 - TRACK MODE ERRORS.

### 5.4.5 TRACK MENU

The TRACK mode MENU system allows the user to view and modify data relating to the satellite being tracked. The MENU system may be invoked whenever the CONFIG mode Expert Access Flag is set by hitting the 0 key while in the SEARCH IDLE, STEP IDLE, and PROGRAM IDLE states. When the menu system is invoked, the user will be presented with the following display, referred to as the main MENU display.

```
1.VIEW 2.MODIFY 3.XXXXXX:_ MENU TRAK K
SAT NAME ENTER TO EXIT
```

The contents of the field XXXXXX: will be 'REPEAK', 'SEARCH', or 'ALIGN', depending on the track submode that is currently active. Note that track operations cease when the MENU system is active. Make sure that you always exit the MENU system. Hitting the ENTER key repeatedly will always cause the MENU system to terminate by returning control to the IDLE state.

## VIEW

From the main MENU display, hit the 1 key to select the VIEW system. Here is the initial view display.

```
TM,AZ,EL TTTTTT AAAAAA EEEEE MENU TRAK K
SAT NAME          SCROLL ^v,ENTER TO EXIT
```

Where

TTTTT is the current sidereal time in seconds  
 AAAAA is the azimuth scale factor in counts per radian  
 and EEEEE is the elevation scale factor in counts per radian

Subsequent toggles on the SCROLL UP/DOWN keys display the following information from the track table.

```
II TTTTTT AAAAAA EEEEE F MENU TRAK K
SAT NAME          SCROLL ^v,ENTER TO EXIT
```

Where

II is the entry index, 0-47  
 TTTTT is the sidereal time in seconds for the entry  
 AAAAA is the azimuth position  
 EEEEE is the elevation position  
 and F denotes the state of the update flag. '.' indicates that the update flag is set, a blank indicates that the update flag is reset.

After the 47th entry has been displayed, the first screen will appear again and the entire process will repeat. To exit this option, press ENTER to return to the MENU screen.

## MODIFY

From the main MENU display hit the 2 key to select the MODIFY system.

```
UPDATE CHECK 0-999 HRS: 72 MENU TRAK K
SAT NAME          SCROLL ^v,ENTER TO EXIT
```

There are 8 data items that the user is allowed to modify with this option. Each is successively accessed by pressing the SCROLL UP/DN keys and advancing through the list. Each entry is explained in Table 1.

TABLE 1

Entry Name	Range	Description
UPDATE CHECK	0-999 HRS	The period of time between track table basepoint update checks. Default 33 hours.
SEARCH RETRY	0-999 MINS	The period of time between successive SEARCH attempts when no signal is present and track table data is not available. Default 10 minutes.
BAND: C,K	1 or 2	For dual band inclined orbit satellites, this prompt allows the user to change the frequency band. Note that the current band is displayed in the upper right hand corner of the LCD.
CLEAR TRACK	0 or 1	Press 1 to clear the track table entries, or 0 to leave as is. Be careful with this one!
RESET UPDATE	0 or 1	Press 1 to clear the track table UPDATE flags, 0 to not modify the existing data.
FORCE UPDATE	0 or 1	Press 1 to set the track table UPDATE flags, 0 to not modify the existing data. (Opposite function of RESET UPDATE.)

MAX ERROR	1-30	Specifies the maximum tracking error in tenths of a dB. Default value is 5.
SEARCH WIDTH	1-10	Specifies a normalized scaling factor that increases or decreases the width of the search window. Values greater than 3 increase it, less than 3 decrease it. Default value is 3.

To exit this option, press ENTER at any time to return to the MENU screen.

REPEAK, SEARCH, or ALIGN

Hitting the 3 key followed by the ENTER key at the main MENU display will initiate some action by the controller. The action taken depends on the TRACK sub-mode that is active. Table 2 describes the action taken for each of the track sub-modes.

TABLE 2

Sub-mode	XXXXXX	Action
STEP	REPEAK	Causes the controller to immediately repeak the antenna.
SEARCH	SEARCH	Causes the controller to initiate another search.
PROGRAM	.ALIGN	The controller will reposition the antenna based on the current sidereal time and the current Az/EI data in the track table.

Selecting item number 3 from the main MENU display will always cause the MENU system to terminate and initiate the selected action.

### 5.5 LIMITS Mode

Limits mode allows the user to jog the antenna in azimuth and elevation and set the azimuth and elevation software limits. If the controller powers up and either the azimuth or elevation limits are corrupted, LIMITS mode is automatically invoked. When LIMITS mode is active, there are not software-imposed restrictions on antenna azimuth and elevation movement. If the antenna is equipped with mechanical limit switches, it is recommended that the user set the mechanical limits before setting the software limits. It may be necessary to recruit a helper to insure that the antenna is not allowed to strike any objects while it is being moved.

Before setting any limits, the user must insure that the antenna motor drive polarity is correct. See section 3.4.1. Note that polarization movement is allowed while LIMIT mode is active, but polarization position and limit information is not displayed. It should be noted that not all versions of the controller support polarization control.

Here is the procedure for setting the limits.

\*\*\*\*\* **WARNING** \*\*\*\*\*  
**THERE ARE NO RESTRICTIONS ON ANTENNA MOVEMENT**  
**WHEN IN THE LIMITS MODE - USE CAUTION!**  
 \*\*\*\*\*

1. Go to LIMITS mode. Hit the ENTER key to advance beyond the warning message. The user will be prompted with the following display.

```
AZ: 5000 EL: 5000 SS1,2: 2, 1 LIMITS
7 - SET CCW LIMIT 9 - SET DOWN LIMIT
```

2. The EL UP, EL DOWN, AZ CCW, AZ CW, POL CW, and POL CCW keys are active. The user should jog the antenna to the desired position for the azimuth counter-clockwise limit and hit the 7 key. When the azimuth counter-clockwise limit is set, the 'SET CCW LIMIT' prompt message will change

to 'SET CW LIMIT' and the azimuth position count will change to 30. The sense of azimuth movement is as seen by an observer located above the antenna.

3. The user should jog the antenna to the desired azimuth clockwise limit and hit the 7 key. The prompt will then change to `* AZIM LIMITS SET *`.
4. The elevation limits are set in a similar manner. It is not necessary to set both the azimuth and elevation limits when LIMITS mode is invoked. Either limit may be set independently of the other.

Note that if LIMITS mode is terminated by hitting the MODE key before both limits associated with a given axis have been set, the limits which existed prior to this entry will be restored if the antenna has not been moved to an antenna position of 1 on that axis. If the unit powers down while LIMITS mode is active, the limit information for both axes will be invalidated.

## 5.6 SETUP Mode

SETUP mode allows a user to store a satellite name, azimuth and elevation positions, and horizontal and vertical polarization presets into the controller's non-volatile memory. Once a satellite has been stored in non-volatile memory, it may be recalled via AUTO mode. Up to 35 satellites may be stored in non-volatile memory. Five of the satellites may be inclined orbit satellites

When SETUP mode is first invoked and the user has hit the ENTER key to advance beyond the warning prompt, the user may jog the antenna in azimuth, elevation, and polarization using the AZ CCW, AZ CW, EL DOWN, EL UP, POL CCW and POL CW keys. The satellite name display (to the right of the 'SAT:' banner) and the H/V keys work in the same manner as for MANUAL mode. Note that the polarization keys and H/V keys are active even when AUTOPOL is enabled. The SCROLL keys may be used to select a satellite name from a list in EPROM memory to be assigned to the new satellite entry. The satellite names accessed by the SCROLL keys are displayed to the right of the 'SELECT:' banner.

Use the jog keys to position the antenna on the desired satellite, and the SCROLL keys to select the satellite name. Hitting the ENTER key initiates a series of prompts where the user specifies the satellite longitude, whether the satellite is in an inclined orbit, the satellite inclination and frequency band(s) (for an inclined orbit satellite), and horizontal and vertical polarization values for the satellite.

Here is the procedure for storing a geostationary satellite into non-volatile memory. All of the geostationary satellites should be stored before any inclined orbit satellites are stored. Depending on the value of the Azim Constant CONFIG mode item, the location of geostationary satellites may be used to initialize the tracking data for an inclined orbit satellite.

The procedure for storing an inclined orbit satellite is described in detail in section 4.4.4.

When SETUP mode is activated, the following screen is displayed.

```
AZ: 1292 EL: 10 PL: 66 H S:653 SETUP
SAT:TELSTAR301 SELECT:SBS 6 FAST
```

When this screen is displayed the AZIM CCW, AZIM CW, EL DOWN, and the EL UP keys may be used to jog the antenna in azimuth and elevation, the SPEED key may be used to toggle the azimuth and elevation jog speed, and the CW, CCW, H and V keys may be used to adjust the polarization (the H and V keys are active only if at least one satellite has been previously stored in non-volatile memory). The SCROLL UP and SCROLL DOWN keys may be used to select the satellite name (in the 'SELECT:' field) which will be stored in non-volatile memory. If the user selects the 'USER' entry from the satellite list, he or she will be prompted to enter in a string of characters (after the ENTER key is pressed). The entry of user defined satellite names is described at the end of this section. While this screen is active the user peaks up the antenna on the satellite which is to be stored in non-volatile memory. When the user has peaked up the antenna on the satellite the ENTER key is depressed.

If the satellite name chosen is already stored in non-volatile memory, the user is presented with the following screen.

```
SELECT:SBS 6 DUPLICATE ENTRY SETUP
OVERWRITE EXISTING DATA, USE YES/NO KEYS
```

If the user selects NO the initial screen is displayed and the selection process is repeated. The user is next prompted to specify whether or not the satellite is in an inclined orbit.

```
SELECT: SBS 6                      SETUP
IS THIS AN INCLINED ORBIT SAT (YES/NO)?
```

The user is next prompted to specify the satellite longitude with the following screen.

```
SELECT: SBS 6                      SETUP
ENTER SAT LON LLL.L: 99.0 W 0-9.ENT, BKSP
```

If the satellite name was not user defined, a value will be present in the longitude field. The longitude is specified in <degrees>.<tenths\_of\_degrees>. Note that the satellite longitude information of geostationary satellites will be used to calculate the antenna azimuth scale factor when the Azim Constant CONFIG mode item is initialized to zero. Be very careful specifying the longitude of geostationary satellites. An error in the entry of longitude data for a geostationary satellite will not affect the controller's ability to position the antenna on that satellite, but it may cause severe problems when attempting to initiate a track on an inclined orbit satellite in the vicinity of the geostationary satellite.

If the satellite being set up is an inclined orbit satellite, the user will next be presented with the following prompt for the satellite band.

```
SELECT: SBS 6                      SETUP
SELECT BAND 0-C, 1-K, 2-C&K, 3-L: ENT, BKSP
```

The response to this prompt will be either the 0, 1, 2, or 3 key.

For an inclined orbit satellite, the user will receive the following prompt for the satellite inclination.

```
SELECT: SBS 6                      SETUP
SAT INCLINATION (2-16):           ENT, BKSP
```

At this prompt, the user should enter the inclination angle of the satellite's orbital plane to the earth's equatorial plane.

For both geostationary and inclined orbit satellites, the user is next prompted to specify the horizontal and vertical polarizations.

```
SELECT: SBS 6      PL: 75          SETUP
USE CW, CCW TO ADJUST - H, V KEYS TO SET
```

When this screen is displayed the CW and CCW keys may be used to adjust the polarization, and the H and V keys may be used to set each polarization. Note that if polarization control is not implemented on the antenna system the Rotating Feed Present CONFIG mode item should be set to zero - this specifies that a Polarotor is present in the system. A Polarotor is a servo type polarization control device which works in an open loop fashion - the controller does not know if it is connected to a Polarotor or not. For this case the user must still specify H and V polarization positions. Any *valid* polarization positions may be specified. An invalid polarization position is one that is outside of or at the CCW and CW limit positions. If the CW or CCW banner is displayed to the right of PL: use the POL CCW or POL CW keys to jog the polarization off of the limit.

If the satellite being set up is in an inclined orbit, the controller will prompt the user to specify the initial track polarization with the following message.

```
INITIAL TRACK POL (H OR V)?
```

At this point the user should select either H or V as the polarization to use for tracking when control switches to TRACK mode. When the user has selected the initial polarization, the 'DATA ACCEPTED' message will appear for a few seconds, and control will switch to TRACK mode.

If the satellite just entered was not an inclined orbit satellite, after the 'DATA ACCEPTED' message appears the controller remains in SETUP mode. Control transfers to the initial screen, and the process may be repeated. Note that the MODE key may be pressed at any time to exit the mode that is currently active.

### User-Defined Satellite Names

If the desired satellite name is not in the controller's EPROM memory, you can assign a new name of up to ten (10) alphanumeric characters (A-Z, 0-9, hyphen (-), or space) by accessing the USER entry mode as follows.

From the screen which allows the user to jog the antenna in azimuth and elevation to peak up on the desired satellite, use the SCROLL UP/DOWN keys to bring up the 'USER' entry in the list, and press ENTER. The following screen will be displayed:

```
SELECT:*                KEY IN SAT NAME  SETUP
USE SCROLL UP/DOWN, BKSP & ENTER KEYS
```

Note that the cursor will be displayed under the '\*' character. The SCROLL UP and SCROLL DOWN keys may be used to select alphanumeric characters (A-Z, 0-9, hyphen (-), and space). A space can be entered in the name by depressing SCROLL UP key once, and SCROLL DOWN key once, and then ENTER (from the '\*' prompt). The BKSP key may be used to delete the character to the left of the cursor. During alphanumeric data entry, the ENTER key has two functions. If the ENTER key is depressed while the '\*' character is displayed, the alphanumeric data entry session is terminated. If the ENTER key is depressed when the '\*' character is not displayed, the cursor will advance to the right one space and the user will be prompted again with the '\*' character. If the ENTER key is depressed when the cursor is in the tenth character position of the satellite name data field the entry is terminated.

## 5.7 RESET Mode

The RESET mode is used to display azimuth, elevation, and polarization drive fault conditions, and to re-enable the drive outputs in the event the microcontroller has disabled an axis. When RESET mode is activated, one of the following screens will be displayed.

```
AZ:  OK      EL:  OK                RESET
RESET AXIS:  1-AZ,  2-EL
```

```
AZ:  OK      EL:  OK      PL:  OK      RESET
RESET AXIS:  1-AZ,  2-EL,  3-POL
```

The first screen will be displayed if Rotating Feed Present CONFIG mode item is set to 0, the second screen will be displayed if the Rotating Feed Present CONFIG mode item is set to 1. There are not fault conditions for a Polarotor. The Polarotor is controlled in an open loop fashion (i.e. the controller cannot tell if it is connected to a Polarotor or not - there is no position or status feedback from the polarotor).

The status of each axis is displayed after the appropriate banner (AZ:, EL:, or PL:) on the top line of the LCD. If a fault exists for an axis, no movement may occur about that axis until the fault condition for that axis is reset. Use the 1 key to reset the azimuth axis, the 2 key to reset the elevation axis, and the 3 key to reset the polarization axis.

Here are the status messages that may be displayed:

#### OK

Indicates that no fault conditions are active for the axis (azimuth, elevation, or polarization).

#### JAMMED

Indicates that the antenna was commanded to move about the axis and no movement was detected by the controller. This indicates either that the antenna did not move when commanded to do so, or the sensor failed and the controller was not able to detect any movement (azimuth, elevation, or polarization).

#### RUNAWAY

The drive was deactivated because the processor sensed movement for a drive that was not commanded to move. This error is rarely caused by an actual runaway condition (the antenna moving on its own). This error is usually due to a faulty sensor or noise pickup due to the sensor shield not being connected properly. See Chapter 3 for proper shield connection instructions (azimuth and elevation).

**DRIVE**

The axis was deactivated due to an overcurrent condition (azimuth, elevation, and high current polarization axis - RC2KHPP option).

**SENSOR**

This error will occur if the antenna commands a polarization movement, and movement is detected in the wrong direction. Note that a polarization jammed condition will occasionally register as a sensor error. Polarization movement in the wrong direction should only occur during setup (polarization axis only).

Note that the azimuth, elevation, and high power polarization (RC2KHPP only - not the RC2KPOL option) axis are also protected from over-currents by a circuit breaker located on the back of the controller. If the circuit breaker opens, the controller will report a JAMMED condition. Note that if simultaneous azimuth and elevation movement is enabled, the total current draw for both axes cannot exceed 8 amps. If the total current draw for both axes exceeds 8 amps, disable simultaneous azimuth and elevation movement via CONFIG mode.

## 5.8 DELETE Mode

```
SELECT A SATELLITE: PANAMSAT-1    DELETE
USE SCROLL UP/DOWN, ENTER TO SELECT
```

This mode is used to delete a satellite entry. This mode can only be activated if the Expert Access flag is set. Refer to section 2.5 for more information on the expert access system.

To delete a satellite from the controller's non-volatile memory:

1. Use the MODE key to activate DELETE mode.
2. Scroll through the ASSIGNED satellite names.
3. When the desired satellite name is shown, press ENTER. The system will display the message:

```
DATA DELETED
```

## 5.9 RE-SYNC Mode

```
SELECT A SATELLITE: PANAMSAT-1    RE-SYNC
USE SCROLL UP/DOWN, ENTER TO SELECT
```

The RE-SYNC feature allows the azimuth and elevation positions of a satellite stored in non-volatile memory to be loaded into the controller's current azimuth and elevation position counters. This feature is useful if a faulty position sensor or a noise impulse results in an errant position count. By using this feature, the user simply has to correct one satellite location, and the RC2000C automatically will correct all others.

1. While in MANUAL mode, jog the antenna to a satellite whose location was previously stored in memory. (NOTE: Do not re-sync using an inclined orbit satellite!) Use a Ku band satellite if possible.
2. Proceed to RE-SYNC mode.
3. Scroll through the list of assigned satellites (in alphabetical order) until the correct satellite name is displayed.
4. Press the ENTER key. The system will respond with the message

```
RE-SYNC ACCOMPLISHED
```

and will return to MANUAL mode.

5. With an assistant out at the antenna, validate the accuracy of the limits by moving the antenna to all four limit positions (Azim CCW, Azim CW, down, and up).

## 5.10 CONFIG Mode

The CONFIG mode allows the user to view and/or modify various controller parameters and to enable or disable certain features. When this mode is active, the SCROLL keys may be used to select various items for either viewing or modification. To change the value of a parameter, the user can simply key in a new value. The BKSP (backspace) KEY is active during data entry. If a new value is keyed in, for the change to take effect and update the parameter's value in the controller's non-volatile memory, the entry must be terminated with the ENTER key. If the present value of the parameter is invalid, '\*' characters will be displayed in the item's data field. If the user terminates a data entry with the ENTER key and the value is accepted, the next CONFIG mode item will be displayed. If the user terminates a data entry with the ENTER key and the data is not accepted, the CONFIG mode item will not change. The MODE key can be pressed at any time to exit CONFIG mode.

Access to certain CONFIG mode items can be restricted depending on the status of the Expert Access flag and by the values currently assigned to certain CONFIG mode items. When the Expert Access flag is reset (see section 2.5), the only CONFIG mode items which will be accessible will be the AutoPol Enable, Simultaneous Az/EI Enable, and Expert Access Enable. When the Expert Access flag is set, access to the other CONFIG mode items can be further restricted by the value of a controlling CONFIG mode item.

An example will clarify the concept of a controlling CONFIG mode item. Three CONFIG mode items related to access to the controller via its serial port are Remote Mode Enable, Comm Port Address, and Comm Baud Rate. The Remote Mode Enable CONFIG item is the controlling item for the Comm Port Address and Comm Baud Rate items. If the Remote Mode Enable CONFIG mode item has a value of 0 (disabled) then the other two items will not appear in the list of CONFIG mode items. In the descriptions which follow the controlling items and the items that are controlled by other items will be clearly delineated.

### 5.10.1 AutoPol

The AutoPol system allows the controller's polarization control function to be slaved to the level of a digital input derived from a satellite receiver. Please refer to sections 2.6 and 3.8 for more information on the AutoPol system.

The AutoPol system is disabled and enabled via the AutoPol Enable CONFIG mode item.

```
AUTOPOL ENABLE:0          CONFIG
0-DISABLE, 1-ENABLE      ENT,BKSP,SCROLL ^v
```

The AutoPol Vpol Level CONFIG mode item specifies the polarity of the AutoPol digital input signal. A value of zero implies that a low on the AutoPol digital input specifies vertical polarization and a value of one implies that a high level on the AutoPol input selects vertical polarization. Access to this item is only allowed when the Expert Access Flag is set.

```
AUTOPOL VPOL LEVEL:1     CONFIG
0-LOW, 1-HIGH           ENT,BKSP,SCROLL ^v
```

### 5.10.2 Simultaneous Azimuth and Elevation Movement

The Simultaneous Az/EI Enable CONFIG mode item is used to enable simultaneous azimuth and elevation movement when moving to a satellite selected via AUTO or REMOTE modes. See section 3.9 for more information on this feature.

```
SIMULTANEOUS AZ/EL ENABLE:0  CONFIG
0-DISABLE, 1-ENABLE      ENT,BKSP,SCROLL ^v
```

**NOTE: If the total current draw from both motors exceeds 8 amps, it is not possible to utilize this feature. Trying to enable it in this case will cause the Az/EI breaker to open, which will disable the drive and generate an antenna jammed error.**

### 5.10.3 Remote Communication Parameters

The following items are used to enable and configure the remote RS-422 communications capability. Access to these parameters is allowed only when the Expert Access flag is set. The Remote Mode Enable item is the controlling item for the Comm Port Address and Comm Baud Rate items.

The Remote Mode Enable item is used to enable access to REMOTE mode. If REMOTE mode is enabled, the controller will respond to serial commands whose address matches the controller's address. If the controller is not in TRACK mode and a valid command is received, control will transfer to REMOTE mode. If TRACK mode is active and a valid command is received, TRACK mode will process the command (without interrupting the track) if the command does not specify azimuth or elevation movement. If the command does specify movement, control will transfer to REMOTE mode and tracking will cease. See the Appendices for the command set.

```
REMOTE MODE ENABLE:0          CONFIG
0-DISABLE, 1-ENABLE        ENT, BKSP, SCROLL ^v
```

The Comm Port Address item selects the address of the communications port. Valid values for this parameter are 49 to 111.

```
COMM PORT ADDRESS: 50        CONFIG
49 - 111                    ENT, BKSP, SCROLL ^v
```

The Comm Baud Rate item selects the baud rate that the controller's serial port will be initialized to. Valid values for this parameter are 3 (300 baud), 6 (600 baud), 12 (1200 baud), 24 (2400 baud), 48 (4800 baud) and 96 (9600 baud).

```
COMM BAUD RATE (HUNDREDS):96  CONFIG
3, 6, 12, 24, 48, 96        ENT, BKSP, SCROLL ^v
```

#### 5.10.4 Azimuth and Elevation Slow Speed Codes

The Azimuth and Elevation Slow Speed CONFIG items can be used to set the azimuth and elevation slow speed codes. Please refer to section 3.5 for more information on the slow speed system. The range of values for these parameters is from 1 to 254. Higher numbers give faster speeds. (For a given axis, a slow speed code of 254 will disable the slow speed system for that axis - all movement will occur at fast speed.) For most motor/sensor combinations, a slow speed code in the range of 140 to 175 is appropriate. If the slow speed codes are changed, test the slow speed system to insure that the selected values yield reasonable results. Access to these CONFIG mode items are allowed only when the Expert Access flag is set. The procedure used to determine the slow speed parameters is described in section 3.5.

To implement slow speed the RC2000 pulse width modulates the voltage applied to the drive motors. In some applications, the +/- 36 volt output of the RC2000 is used to activate controls that energize the motors which actually move the antenna. For these applications slow speed should be disabled by setting the azimuth and elevation slow speed codes to 254. More information on these applications is available in the paper entitled 'Controlling Antennas Powered by AC or Large DC Motors with the RC1000 or RC2000 Antenna Controllers'. With some controller's this paper is included as an addendum to this manual. The paper is also available from RCI.

```
AZIM SLOW SPEED 0-254:253    CONFIG
                              ENT, BKSP, SCROLL ^v
```

```
ELEV SLOW SPEED 0-254:253    CONFIG
                              ENT, BKSP, SCROLL ^v
```

#### 5.10.5 Azimuth and Elevation Angle Display

The RC2000C has the ability to display azimuth and elevation position in an angle format. This feature can greatly facilitate the process of locating satellites for systems that use an elevation over azimuth type antenna mount. Please see section 3.7 for more information on how to enable and calibrate this feature. Access to these CONFIG mode items is allowed only when the Expert Access flag is set.

Briefly, to calibrate the angle display feature, the user locates two satellites and records their azimuth and elevation position count values. The scale3.exe PC program (for IBM compatibles - shipped with each controller in the back of this manual) is then used to calculate azimuth and elevation scale factors that are entered into controller via the CONFIG mode items described in this section. The scale3.exe program

prompts for the antenna latitude and longitude, and the longitude, azimuth position count, and elevation position count values for a pair of satellites which have been located with the controller.

The Angle Display Enable item is the controlling item for the other items described in this section. When this parameter is set to 1 (enabled), azimuth and elevation positions are displayed in an angle format using the other items described in this section.

```
ANGLE DISPLAY ENABLE: 0          CONFIG
0-DISABLE, 1-ENABLE    ENT, BKSP, SCROLL ^v
```

The Display Az Gain and Display Az Offset items are used to calibrate the display of azimuth position according to the following formula:

(Northern Hemisphere)

$$\text{Display\_Angle (tenths of degrees)} = 1800 + ((100 * (\text{Azim\_Position\_Cnt} - \text{Display\_Az\_Offset})) / \text{Display\_Az\_Gain})$$

(Southern Hemisphere - Note the displayed angle is adjusted by adding or subtracting 3600 so that the result is in the range of 0 to 360.0 degrees.)

$$\text{Display\_Angle (tenths of degrees)} = 3600 - ((100 * (\text{Azim\_Position\_Cnt} - \text{Display\_Az\_Offset})) / \text{Display\_Az\_Gain})$$

The range of values that the user must specify for the 'DISPLAY AZ OFFSET' CONFIG mode item is 0 to 65535. Values in the range of 32768 to 65535 are converted to negative offset values for Display\_Az\_Offset in the above equations according to the following relationship:

$$\text{Display\_Az\_Offset} = \text{DISPLAY AZ OFFSET (CONFIG mode item entered by user)} - 65536$$

This is necessary because it is not possible to enter negative values via the keypad on the RC2000C.

```
DISPLAY AZ GAIN: 1          CONFIG
ENT, BKSP, SCROLL ^v
```

```
DISPLAY AZ OFFSET: 0        CONFIG
ENT, BKSP, SCROLL ^v
```

The Display EI Gain and Display EI Offset items are used to calibrate the display of elevation position according to the following formula:

$$\text{Display\_Angle (tenths of degrees)} = (100 * (\text{Elev\_Position\_Cnt} + \text{Display\_EI\_Offset})) / \text{Display\_EI\_Gain}$$

The range of values that the user must specify for the Display EI Offset CONFIG mode item is 0 to 65535. Values in the range of 32768 to 65535 are converted to negative offset values for Display\_EI\_Offset in the above equations according to the following relationship:

$$\text{Display\_EI\_Offset} = \text{DISPLAY EL OFFSET (CONFIG mode item entered by user)} - 65536$$

This is necessary because it is not possible to enter negative values via the keypad on the RC2000C.

```
DISPLAY EL GAIN: 1          CONFIG
ENT, BKSP, SCROLL ^v
```

```
DISPLAY EL OFFSET: 0        CONFIG
ENT, BKSP, SCROLL ^v
```

### 5.10.6 Polarization Motor Option

The RC2KPOL option allows the RC2000C to control a 12 or 24-volt polarization motor with potentiometer position feedback. If this option is present, a 5 position orange connector will be found on the upper left hand corner of the back panel. The CONFIG mode items described in this section are used to configure the controller to work with the RC2KPOL option. Access to these CONFIG mode items is allowed only if the Expert Access flag is set. The Rotating Feed Present item is the controlling item for access to the other items described in this section.

The Rotating Feed Present CONFIG mode item is used to inform the controller of whether or not a polarotor is present in the system. If the RC2KPOL option is installed this parameter should be set to YES (see section 3.3).

```
ROTATING FEED PRESENT?:1          CONFIG
O-NO 1-YES                        ENT, BKSP, SCRLl ^v
```

The following items set the controller's CW and CCW polarization limits when a rotating feed is installed. The procedure to determine these limits is given in section 3.3. Note that the CW limit must by definition be less than the CCW limit.

```
ROTATING FEED CW LIMIT:           CONFIG
0-1023                            ENT, BKSP, SCRLl ^v
```

```
ROTATING FEED CCW LIMIT:         CONFIG
0-1023                            ENT, BKSP, SCRLl ^v
```

The Rotating Feed Jog Duration CONFIG mode item controls the length of time (in milliseconds) that the polarization motor drive signals are applied when a polarization jog command is received via the serial communications port. The setting of this parameter determines the accuracy with which the polarization can be adjusted via remote control.

```
ROTATING FEED JOG DURATION:1000  CONFIG
175-3000 MSEC                     ENT, BKSP, SCRLl ^v
```

### 5.10.7 Azimuth and Elevation Drive Options

The CONFIG mode items described in this section set the movement parameters for the azimuth and elevation axis. The default values of these parameters (as initialized upon system reset) are adequate for use with 36-volt linear actuators. For systems employing linear actuators, it is recommended that these values not be changed from the default values. The provision to modify these parameters is included for those customers who use the azimuth and elevation drive outputs from the RC2000C to drive a pair of 36 volt relays (equipped with steering diodes) which in turn activate AC motors. More information about using the RC2000C in this fashion may be found in the Appendix entitled "Controlling Antennas Powered by AC or Large DC Motors with the RC1000 or RC2000 Antenna Controllers". Access to the CONFIG mode items described in this section is permitted only when the Expert Access flag is set.

The Az/EI Drive Options Enable CONFIG mode item is the controlling item for the other CONFIG mode items described in this chapter. When this item is disabled the user does not have access (via CONFIG mode) to the other items described in this section. Note that when this item is disabled, the current values of the other items described in this section are used to control azimuth and elevation movement. In other words, disabling this item does not reset the other items described in this section to their default values.

```
AZ/EL DRIVE OPTIONS ENABLE:0      CONFIG
0-DISABLE, 1-ENABLE              ENT, BKSP, SCRLl ^v
```

During an automatic move, when the antenna position is within Az/EI Fast/Slow Threshold position counts of the target position, the antenna speed will switch from fast to slow.

```
AZ/EL FAST SLOW THRESHOLD: 80     CONFIG
0-400 COUNTS                     ENT, BKSP, SCRLl ^v
```

The Az/EI Auto Retry Attempts CONFIG mode item sets the maximum number of attempts which will be made to hit a target position (within Max Position Error counts - described below) during an automatic move initiated from AUTO or TRACK modes.

```
AZ/EL AUTO RETRY ATTEMPTS: 3          CONFIG
2-5                                  ENT, BKSP, SCROLL ^v
```

The 'Fast Deadband and 'Slow Deadband CONFIG mode items are used for the anti-reversal system. To understand the purpose of these parameters, it is necessary to consider how position counts are accumulated. The feedback from the azimuth and elevation position sensors are pulses. When a pulse is received, the controller checks to see which way the antenna was last commanded to move. If the antenna is moving, or last moved, azimuth CCW (down), the azimuth (elevation) position count is decremented. If the antenna is moving, or last moved, azimuth CW (up) the azimuth (elevation) position count is incremented.

In MANUAL mode, the user can jog the antenna. If the UP arrow key is depressed, the antenna will move up. If the user suddenly depresses the DOWN arrow key and the antenna drive signals were instantaneously reversed, the antenna continues to move up for some small period of time, then the antenna reverses direction and starts to move down. This can cause position count errors. When the antenna drive signals are configured for down movement but the antenna is still moving up, pulses which are received would cause the elevation position count to decrement when the count should really be incremented because the antenna is really still moving up.

The anti-reversal system keeps the antenna from rapidly changing direction. If the antenna has been moving in a given direction, the 'Deadband CONFIG mode items specify the amount of time that the system will wait before asserting the antenna drive lines to move the antenna in the opposite direction. There are 2 different 'Deadband values specified - there are unique fast and slow speed values. If the antenna has been moving fast, the 'Fast Deadband parameters specify the wait interval; if the antenna has been moving slow, the 'Slow Deadband parameters specify the wait interval. Both 'Deadband values are given in milliseconds.

```
AZ/EL FAST DEADBAND: 2000           CONFIG
175-5000 MSEC                       ENT, BKSP, SCROLL ^v
```

```
AZ/EL SLOW DEADBAND: 800           CONFIG
175-5000 MSEC                       ENT, BKSP, SCROLL ^v
```

The values assigned to the Az/EI Fast Deadband and Az/EI Slow Deadband variables can affect other systems on the controller not related to the anti-reversal system. These features are explained in Chapter 7 - Operational Troubleshooting Tips. For normal operation these features should be disabled. To DISABLE these features, make sure that the value entered for Az/EI Fast Deadband DOES NOT end in '01' (i.e. when the value is divided by 100 the remainder is not 1), and that the value entered for Az/EI Slow Deadband DOES end in either '00' or '50' (i.e. the value entered is a multiple of 50).

During an automatic move in AUTO or TRACK modes, the 'Coast Threshold CONFIG mode items set the number of counts before the target position is reached where the drive will be deactivated. The idea is to deactivate the drive and let the antenna coast into position. If prior to the initiation of the move operation, the total number of counts that the actuator has to move to reach the target position is less than the 'Coast Threshold, the drive will be deactivated when its position is within 'Max Position Error counts of the target position.

```
AZIM COAST THRESHOLD: 4             CONFIG
1-40 COUNTS                          ENT, BKSP, SCROLL ^v
```

```
ELEV COAST THRESHOLD: 4            CONFIG
1-40 COUNTS                          ENT, BKSP, SCROLL ^v
```

The 'Max Position Error CONFIG mode items set the maximum acceptable error between the final resting position and a target position for an automatic move which occurs in AUTO mode.

```
AZIM MAX POSITION ERROR: 0           CONFIG
0-10 COUNTS                          ENT, BKSP, SCROLL ^v
```

```
ELEV MAX POSITION ERROR: 0          CONFIG
0-10 COUNTS                      ENT, BKSP, SCRLl ^v
```

### 5.10.8 Time and Date Settings

Access to the Time and Date CONFIG mode items is permitted only when the Expert Access flag is set.

```
ENTER TIME (HH.MM.SS): 08.46.00   CONFIG
USE 0-9 OR .                      ENT, BKSP, SCRLl ^v
```

The real-time clock must be set to establish a time reference for all tracking data stored in the controller. Enter the local time using the 0-9 keys and the "." key to separate the hours, minutes, and seconds fields. Each field must have two digits entered; i.e., 8 must be entered as 08 or the unit will not accept the entry. The time cannot be changed for daylight-savings time purposes once valid track data is stored, or the unit will not function properly.

```
ENTER DATE (MM.DD.YY): 07.03.01   CONFIG
USE 0-9 OR .                      ENT, BKSP, SCRLl ^v
```

Enter the current date in the format shown. Again, use the 0-9 keys to enter the month, day, and year fields, and use the "." key to separate fields. Single digit fields must be entered with a 0 preceding the significant digit, as shown in the example for 07.03.92.

### 5.10.9 Signal Strength Parameters

The controller has to have signal strength information for tracking inclined orbit satellites. Signal strength information is generally obtained from the receiver's automatic gain control (AGC) system. The procedures used to adjust the controller's AGC input circuits and obtain these parameters are described in section 4.4.1 - AGC Adjustment and Configuration. Access to these CONFIG mode items is permitted only when the Expert Access Flag is set.

```
AGC POLARITY FLAG;1              CONFIG
0-NEGATIVE 1-POSITIVE          ENT, BKSP, SCRLl ^v
```

The AGC Polarity Flag tells the controller what the sense is on the input AGC voltage used for tracking. A positive sense is defined as a voltage that increases in magnitude as the RF signal strength increases. If the AGC voltage decreases as the RF signal increases, its sense is considered negative. Enter the appropriate value, either 0 or 1, followed by ENTER to key in the value.

```
AGC C BAND THRESHOLD:125         CONFIG
0 - 999                        ENT, BKSP, SCRLl ^v
```

When the receiver is tuned to a C band satellite and the signal strength is above the AGC C Band Threshold value, it is assumed that a satellite signal is present. The same threshold is applied to both AGC channels.

```
AGC K/L BAND THRESHOLD:150      CONFIG
0 - 999                        ENT, BKSP, SCRLl ^v
```

This is similar to the C band threshold described above, except it pertains to Ku or L band. If the signal strength is above the AGC K/L Band Threshold value when the receiver is tuned to a Ku or L band satellite, the controller assumes that a satellite signal is present.

### 5.10.10 Antenna Parameters

The following items specify antenna related parameters that are used by the tracking system. Access to these items is only permitted when the Expert Access flag is set.

```
ANTENNA LATITUDE LL.L: 38.9 N    CONFIG
TENTHS AFTER DEC. PT            ENT, BKSP, SCRLl ^v
```

```
ANTENNA LONGITUDE LLL.L: 97.5 W  CONFIG
```

```
TENTHS AFTER DEC. PT  ENT ,BKSP ,SCROLL ^v
```

The antenna/downlink location is necessary for the satellite track path prediction algorithm. The format for these entries is <degrees>.<tenths of degrees> (as opposed to a <degrees>.<minutes> format found on most maps). A conversion table from minutes to tenths of degrees is shown below.

<u>Minutes</u>	<u>Tenths of Degrees</u>
00	.0
06	.1
12	.2
18	.3
24	.4
30	.5
36	.6
42	.7
48	.8
54	.9

After entering the latitude/longitude using the 0-9 and "." keys, press ENTER. The RC2000C will prompt for the appropriate direction terminator, E/W for longitude, N/S for latitude. Enter the correct value using the 2-North, 8-South, 4-East, or 6-West keys. Terminate the entry with the ENTER key.

```
ANT SIZE (40 - 1200):244  CONFIG
CENTIMETERS  ENT ,BKSP ,SCROLL ^v
```

The Antenna Size is used to calculate various parameters associated with TRACK mode. The size is specified in centimeters, and the following table lists some common sizes.

<u>Diameter in Feet</u>	<u>Meters</u>	<u>RC2000C Input</u>
5.9	1.8	180
8.0	2.44	244
10.0	3.05	305
12.0	3.66	366
15.0	4.57	457
20.0	6.1	610
23.0	7.0	700

Use the 0-9 keys followed by ENTER to input the antenna diameter.

```
AZIM CONSTANT: 1200  CONFIG
CNT PER RAD,0-DISABLE  ENT ,BKSP ,SCROLL ^v
```

```
ELEV CONSTANT: 500  CONFIG
CNT PER RAD,100-65535  ENT ,BKSP ,SCROLL ^v
```

The Azim and Elev Constants relate changes in the antenna azimuth and elevation pointing angles to changes in the antenna azimuth and elevation position count values. The Azim Constant and Elev Constant are specified in position counts per radian. One radian equals 57.295 degrees. See section 4.4.2 for a complete description of these CONFIG mode items.

These quantities are referred to as the azimuth and elevation scale factors in chapter four, which describes the tracking algorithms. A value must always be entered for the Elev Constant. Entry of the Azim constant is optional. If the Azim Constant is initialized to a value of zero, when a track is initiated on an inclined orbit satellite, the controller will attempt to determine the azimuth scale factor based on the positions of geostationary satellites in the vicinity of the inclined orbit satellite. If the user chooses to let the controller determine the azimuth scale factor, it is very important to specify correct longitude values for geostationary satellites (via SETUP mode).

### 5.10.11 Track Mode Parameters

The following parameters are used by the track system. These parameters are described in more detail in chapter 4. These items may only be accessed when the Expert Access flag is set.

#### MAX TRACK ERROR

```
MAX TRACK ERROR(1-30):5          CONFIG
IN TENTHS OF A dB             ENT, BKSP, SCRL ^v
```

The Max Track Error CONFIG mode item specifies the maximum antenna tracking error in tenths of a dB. This parameter has more influence over the operation of the tracking system than any other. The significance of this variable is described in detail in sections 4.2.1 and 4.2.2 of this manual, which cover the operation of the controller in the STEP TRACK and PROGRAM TRACK sub-modes.

In the STEP TRACK sub-mode, the value of this parameter determines how often peaking operations occur. The controller will peak the antenna often enough so that in between peakups the signal strength variation due to antenna pointing error will not exceed Max Track Error tenths of a dB.

In the PROGRAM TRACK sub-mode, the controller tracks the satellite based on the current sidereal time, and data in the track table. The controller will reposition the antenna often enough so that the error between the antenna's azimuth and elevation position and the azimuth and elevation positions derived from interpolation of track table data is less than Max Track Error tenths of a dB.

The Max Track Error parameter specifies the azimuth and elevation step sizes during peaking operations that occur during the STEP TRACK and PROGRAM TRACK sub-modes. Some users erroneously conclude that the smallest value of Max Track Error leads to the tightest track. When the value of this parameter is reduced to a point where the peakup azimuth or elevation step sizes approach the value of the mechanical hysteresis (slop) of the antenna mount, the controller cannot peakup properly. This can lead to PEAK LIMIT errors, or the antenna peaking itself off of the antenna.

Here is the mechanism that can lead to this undesirable result:

1. The Max Track Error parameter is set to a 'low' value that results in an elevation peakup step size of just one position count.
2. When a peakup occurs, the controller measures the signal strength at the current antenna position, and then moves the antenna up or down in elevation in an attempt to find the strongest satellite signal. After recording the signal strength at the starting position, the controller moves the antenna up in elevation by one position count.
3. Due to mechanical hysteresis, the antenna's pointing angle does not change even though the antenna's elevation actuator has moved one position count.
4. Thermal noise in the receiver's AGC circuit or changing atmospheric conditions result in the controller measuring a stronger AGC input at the 'new' antenna position.
5. Since a stronger signal was measured when the antenna moved up, the controller concludes that the satellite has moved up. The controller will record the signal strength at the current antenna position, and again move up by one position count. At the new position, the controller will measure the signal strength again to determine if the signal is stronger at the new position than at the starting position. This process will continue until a weaker signal strength is recorded. When that occurs, the controller will back up one step and conclude that it has found the elevation peak.
6. A problem occurs if the controller makes the wrong decision at step 4. Any time the controller step size is comparable in magnitude to the antenna's mechanical hysteresis, a problem WILL eventually occur.

For most antennas the Max Track Error should not be made smaller than 5 (0.5 dB).

#### SEARCH ENABLE

```
SEARCH ENABLE:1          CONFIG
```